

**MISSISSIPPI**  
**STANDARD SPECIFICATIONS**  
**FOR**  
**STATE AID ROAD AND BRIDGE CONSTRUCTION**



**OFFICE OF STATE AID ROAD CONSTRUCTION**  
**MISSISSIPPI DEPARTMENT OF TRANSPORTATION**  
**JACKSON, MISSISSIPPI**

---

**2004 EDITION**



**MISSISSIPPI**  
**STANDARD SPECIFICATIONS**  
**FOR**  
**STATE AID ROAD AND BRIDGE CONSTRUCTION**

BOOK NO. \_\_\_\_\_



**APPROVED AND ADOPTED**  
**BY**  
**THE OFFICE OF STATE AID ROAD CONSTRUCTION**  
**MISSISSIPPI DEPARTMENT OF TRANSPORTATION**  
**JACKSON, MISSISSIPPI**

---

**July1, 2004**



## STANDARD SPECIFICATIONS

Edition of 2004

In compliance with Section 65-9-11, MISSISSIPPI CODE 1972, Annotated, the State Aid Engineer has caused to be revised and updated the Standard Specifications for State Aid Road and Bridge Construction. The best practices governing road and bridge construction have been followed and every effort has been made to provide specifications that are in keeping with expected traffic demands and needs on County Roads on the State Aid System, so that the most miles of roads and bridges may be constructed with available funds.

These revised specifications, designated as the 2004 Edition, are hereby adopted as the Mississippi Standard Specifications for State Aid Road and Bridge Construction.

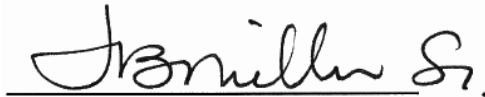
A handwritten signature in black ink, reading "J. Brooks Miller, Sr.", is written over a light gray rectangular background. The signature is cursive and includes a period at the end.

J. Brooks Miller, Sr.

State Aid Engineer

July 1, 2004



**SECTION S-100 - GENERAL PROVISIONS**

<b><u>Section</u></b>	<b><u>Page</u></b>
S-100 - GENERAL PROVISIONS	1-1
S-101 - DEFINITIONS AND TERMS	1-1
S-102 - BIDDING REQUIREMENTS AND CONDITIONS	1-14
S-103 - AWARD AND EXECUTION OF CONTRACT	1-21
S-104 - SCOPE OF WORK	1-25
S-105 - CONTROL OF WORK	1-31
S-106 - CONTROL OF MATERIALS	1-44
S-107 - LEGAL RELATIONS AND RESPONSIBILITY TO PUBLIC	1-50
S-108 - PROSECUTION AND PROGRESS	1-68
S-109 - MEASUREMENT AND PAYMENT	1-78
S-110 - REQUIRED CONTRACT PROVISIONS	1-91
S-111 thru S-199--Blank	1-92
FIGURE - 1. PAVEMENT STRUCTURE	1-93

**SECTION S-200 - EARTHWORK**

S-200 - MOBILIZATION	2-1
S-201 - CLEARING AND GRUBBING	2-2
S-202 - REMOVAL OF STRUCTURES AND OBSTRUCTIONS	2-5
S-203 - EXCAVATION AND EMBANKMENT	2-8
S-204 - Blank	2-21
S-205 - SUBGRADE PREPARATION	2-22
S-206 - STRUCTURE EXCAVATION FOR CULVERTS, BOXES AND MINOR STRUCTURES	2-24

S-207 - Blank	2-26
S-208 - LINEAR GRADING	2-27
S-209 - Blank	2-29
S-210 - ROADSIDE DEVELOPMENT - GENERAL PROVISIONS	2-30
S-211 - TOPSOILING	2-31
S-212 - GROUND PREPARATION AND FERTILIZER	2-35
S-213 - Blank	2-37
S-214 - SEEDING	2-38
S-215 - MULCHING	2-42
S-216 - thru S-225 - Blank	2-44
S-226 - SOLID SODDING	2-45
S-227 - EXCELSIOR BLANKET	2-48
S-228 - Blank	2-49
S-229 - PAVED DITCHES	2-50
S-230 - BITUMINOUS TREATED ROVING	2-52
S-231 - EROSION CONTROL FABRIC	2-54
S-232 - GEOTEXTILE FABRIC STABILIZATION	2-56
S-233 - TEMPORARY SILT FENCE	2-58
S-234 - Blank	2-60
S-235 - TEMPORARY EROSION CHECKS	2-61
S-236 - TEMPORARY SILT BASINS	2-62
S-237 - thru S-238 - Blank	2-63
S-239 - TEMPORARY SLOPE DRAINS	2-64



S-240 - GEOGRID REINFORCEMENT OF EMBANKMENT SLOPES AND SUBGRADES 2-66

S-241 - thru S-299 - Blank 2-68

**SECTION S-300 - SUBBASES AND BASES**

S-300 - SUBBASES AND BASES 3-1

S-301 - thru S-303 - Blank 3-1

S-304 - GRANULAR COURSES 3-2

S-305 - and S-306 - Blank 3-7

S-307 - LIME TREATED COURSES 3-8

S-308 - PORTLAND CEMENT TREATED COURSES 3-19

S-309 - Blank 3-30

S-310 - MECHANICALLY STABILIZED COURSES 3-31

S-311 - LIME-FLY ASH TREATED COURSES 3-37

S-312 - thru S-319 - Blank 3-41

S-320 - SHOULDERS 3-42

S-321 - thru S-399 - Blank 3-44

**SECTION S-400 - BITUMINOUS PAVEMENTS**

S-400 - BITUMINOUS PAVEMENTS 4-1

S-401 - PLANT MIX PAVEMENTS (HMA) - GENERAL 4-1

S-402 - Blank 4-29

S-403 - HOT MIX ASPHALT PAVEMENT 4-30

S-404 - and S-405 - Blank 4-38

S-406 - COLD MILLING 4-39

S-407 - TACK COAT	4-41
S-408 - PRIME COAT	4-43
S-409 - GEOTEXTILE FABRIC FOR UNDERSEAL	4-45
S-410 - BITUMINOUS SURFACE TREATMENT	4-48
S-411 - SLURRY SEAL	4-59
S-412 - Blank	4-70
S-413 - CLEANING AND SEALING JOINTS AND CRACKS	4-71
S-414 - thru S-499 - Blank	4-75

**SECTION S-500**

S-501 - thru S-599 - Blank	
----------------------------	--

**SECTION S-600 - INCIDENTAL CONSTRUCTION**

S-600 - INCIDENTAL CONSTRUCTION	6-1
S-601 - STRUCTURAL CONCRETE	6-1
S-602 - REINFORCING STEEL	6-6
S-603 - CULVERTS AND STORM DRAINS	6-9
S-604 - MANHOLES, INLETS AND CATCH BASINS	6-23
S-605 - UNDERDRAINS	6-28
S-606 - GUARD RAIL	6-35
S-607 - Blank	6-39
S-608 - CONCRETE SIDEWALKS AND DRIVEWAYS	6-40
S-609 - CONCRETE GUTTER, CURB AND COMBINATION CURB AND GUTTER	6-43

S-610 - Blank	6-47
S-611 - BRICK MASONRY	6-48
S-612 - PRESSURE GROUTING	6-51
S-613 - ADJUSTMENT OF CASTINGS, GRATINGS AND UTILITY APPURTENANCES	6-58
S-614 - and S-615 - Blank.	6-59
S-616 - TRAFFIC ISLAND PAVEMENT	6-60
S-617 - RIGHT-OF-WAY MARKERS	6-64
S-618 - MAINTENANCE OF TRAFFIC AND TRAFFIC CONTROL PLAN	6-66
S-619 - HOT SPRAY PAINT TRAFFIC MARKINGS	6-72
S-620 - COLD PLASTIC PAVEMENT MARKINGS	6-77
S-621 - THERMOPLASTIC TRAFFIC MARKINGS	6-79
S-622 - thru S-626 - Blank	6-82
S-627 - RAISED PAVEMENT MARKERS	6-83
S-628 - and S-629 - Blank	6-85
S-630 - TRAFFIC SIGNS AND DELINEATORS	6-86
S-631 - FLOWABLE FILL	6-91
S-632 - ROADBED RECLAMATION	6-94
S-633 - thru S-699 - Blank	6-98

<u>Section</u>	<u>Page</u>
S-700 - MATERIALS AND TESTS	7-1
S-701 - HYDRAULIC CEMENT	7-8
S-702 - BITUMINOUS MATERIALS	7-10
S-703 - AGGREGATES	7-20
S-704 - AGGREGATE FOR DRAINAGE	7-39
S-705 - STONE BLANKET PROTECTION AND FILTER BLANKET MATERIALS	7-40
S-706 - MASONRY UNITS	7-42
S-707 - JOINT MATERIALS	7-44
S-708 - NON-METAL STRUCTURES AND CATTLEPASSES	7-52
S-709 - METAL PIPE	7-62
S-710 - PAINT	7-66
S-711 - REINFORCEMENT AND WIRE ROPE	7-78
S-712 - GUARDRAIL	7-84
S-713 - CONCRETE CURING MATERIALS AND ADMIXTURES	7-85
S-714 - MISCELLANEOUS MATERIALS	7-87
S-715 - ROADSIDE DEVELOPMENT MATERIALS	7-107
S-716 - MISCELLANEOUS METALS	7-116
S-717 - STRUCTURAL STEEL	7-119
S-718 - TIMBER AND DIMENSION LUMBER	7-130
S-719 - PILES	7-136
S-720 - PAVEMENT MARKING MATERIALS	7-138
S-721 - MATERIALS FOR SIGNING	7-153
S-722 - GEOGRIDS	7-164
S-723 - thru S-799 - Blank	7-165

<u>Section</u>	<u>Page</u>
S-800 - BRIDGES AND STRUCTURES	8-1
S-801 - EXCAVATION AND FILL	8-1
S-802 - SHEET PILING	8-6
S-803 - DEEP FOUNDATIONS	8-8
S-804 - CONCRETE BRIDGES AND STRUCTURES	8-51
S-805 - REINFORCEMENT	8-109
S-806 - PRECAST CONCRETE BRIDGES	8-113
S-807 - thru S-809 - Blank	8-122
S-810 - STEEL STRUCTURES	8-123
S-811 - BRONZE OR COPPER-ALLOY BEARING AND EXPANSION PLATES	8-155
S-812 - STEEL GRID FLOORING	8-156
S-813 - RAILING	8-159
S-814 - PAINTING METAL STRUCTURES	8-162
S-815 - RIP RAP AND SLOPE PAVING	8-167
S-816 - MAINTENANCE PAINTING OF METAL STRUCTURES	8-172
S-817 - thru S-819 - Blank	8-175
S-820 - TIMBER STRUCTURES	8-176
S-821 - Blank	8-183
S-822 - NEOPRENE EXPANSION JOINTS	8-184
S-823 - thru S-899 - Blank	8-184

STATE AID SECTION S-900 - CONTRACT DOCUMENTARY FORMS STATE AID 2004  
(Under Separate Cover)

**Section**

- 900 NOTICE TO BIDDERS
- 901 SPECIAL PROVISIONS
- 902 PROPOSAL
- 903 CONTRACT
- 904 CONTRACT BOND
- 905 FEDERAL AID CONTRACT LABOR PROVISIONS

<u>Section</u>	<u>Page</u>
S-100 - GENERAL PROVISIONS	1-1
S-101 - DEFINITIONS AND TERMS	1-1
S-102 - BIDDING REQUIREMENTS AND CONDITIONS	1-14
S-103 - AWARD AND EXECUTION OF CONTRACT	1-21
S-104 - SCOPE OF WORK	1-25
S-105 - CONTROL OF WORK	1-31
S-106 - CONTROL OF MATERIALS	1-44
S-107 - LEGAL RELATIONS AND RESPONSIBILITY TO PUBLIC	1-50
S-108 - PROSECUTION AND PROGRESS	1-68
S-109 - MEASUREMENT AND PAYMENT	1-78
S-110 - REQUIRED CONTRACT PROVISIONS	1-91
S-111 - thru S-199 - Blank	1-92
FIGURE - 1. PAVEMENT STRUCTURE	1-93





It is understood and agreed that all of the provisions and requirements of the GENERAL PROVISIONS - SECTION S-100 through SECTION S-199 of these specifications shall be applicable to all contracts.

It is further understood and agreed that, in addition to the above, the requirements of Figure 1, Page 1-93, S-100, of these specifications shall be applicable to all contracts on which the typical section(s) of the plans contemplate the construction of shoulders or any or all of the elements of the pavement structure.

### **SECTION S-101 - DEFINITIONS AND TERMS**

Wherever in these specifications or in other contract documents the following terms or pronouns in place of them are used, the intent and meaning shall be interpreted as follows:

**S-101.01--Abbreviations.** Wherever the following abbreviations are used, with or without periods, in these specifications or other contract documents, they are to be construed the same as the respective expressions represented:

AAN	American Association of Nurserymen
AAR	Association of American Railroads
AASHTO	American Association of State Highway and Transportation Officials
ACI	American Concrete Institute
AGC	Associated General Contractors
AIA	American Institute of Architects
AIEE	American Institute of Electrical Engineers
AISC	American Institute of Steel Construction
AISI	American Iron and Steel Institute
AITC	American Institute of Timber Construction
ANSI	American National Standards Institute
AOAC	Association of Official Analytical Chemists
API	American Petroleum Institute
APWA	American Public Works Association
ARA	American Railway Association
ARBA	American Road Builders Association
AREA	American Railway Engineering Association
ARTBA	American Road and Transportation Builders Association
ASCE	American Society of Civil Engineers
ASLA	American Society of Landscape Architects
ASME	American Society of Mechanical Engineers
ASTM	American Society for Testing and Materials
AWG	American Wire Gage
AWPA	American Wood Preservers Association
AWS	American Welding Society
AWWA	American Water Works Association

BMP	Best Management Practices
CBR	California Bearing Ratio
CFR	Code of Federal Regulations
CRSI	Concrete Reinforcing Steel Institute
CCR	Construction Change Request
CS	Commercial Standards, U. S. Department of Commerce
CSPI	Corrugated Steel Pipe Institute
CWA	Clean Water Act
DEQ	Department of Environmental Quality
EIA	Electronic Industries Association
EOSE	Estimated On Site Excavation
EPA	Environmental Protection Agency
FHWA	Federal Highway Administration
FM	Final Measure
FME	Final Measure Embankment
FSS	Federal Specifications and Standards (General Services Administration)
HMA	Hot Mix Asphalt
HRB	Highway Research Board
ID	Inside Diameter
IES	Illuminating Engineering Society
IMSA	International Municipal Signal Association
IPS	Interior Pipe Size
IS	Interim Specification
ITE	Institute of Traffic Engineers
LVM	Loose Vehicular Measure
MAPA	Mississippi Asphalt Pavement Association
MBM	Thousand Feet Board Measure
MDEQ	Mississippi Department of Environmental Quality
MDOT	Mississippi Department of Transportation
MS	Military Specifications
MSG	Manufacturers Standard Gage
MUTCD	Manual on Uniform Traffic Control Devices
NACE	National Association of Corrosion Engineers
NAPA	National Asphalt Pavement Association
NBC	National Building Code
NBS	National Bureau of Standards
NEC	National Electric Code
NEMA	National Electrical Manufacturers Association
NPC	National Plumbing Code
NPDES	National Pollutant Discharge Elimination System
NSF	National Sanitation Foundation
NTB	Notice To Bidders
OD	Outside Diameter
OSHA	Occupational Safety and Health Administration

PCI	Prestressed Concrete Institute
PM	Plan Measure
RAP	Recycled Asphalt Pavement
RCRA	Resource Conservation and Recovery Act
SA	Supplemental Agreement
SAE	Society of Automotive Engineers
SOP	The Office of State Aid Road Construction
	Standard Operating Procedures
SP	Special Provisions
SS	Supplemental Specifications
SSPC	Steel Structures Painting Council
SWPPP	Storm Water Pollution Prevention Plan
TRB	Transportation Research Board
TSR	Tensile Strength Ratio
UL	Underwriters Laboratories, Inc.
UNC	Upset National Coarse Threaded Bolts
UST	Underground Storage Tank

### **S-101.02--Definitions.**

Additive - A substance or agent added in small amounts to a basic ingredient of a mixture prior to mixing.

Admixture - A substance or agent added in small amounts to the basic ingredients of a mixture during the mixing process.

Advertisement - The public announcement, as required by law, inviting bids for work to be performed or materials to be furnished.

Alternate Designs - Alternate design of construction or of construction and materials designated in the bid schedule of the proposal as Alternate Designs which must be pre-selected by the Contractor and indicated on his bid. Alternate Designs may contain Alternate or Optional Items.

Alternate Items - Alternate pay items of work, or materials and work designated in the bid schedule of the proposal as Alternate Items, with separate pay item numbers, and which must be preselected by the Contractor and indicated on his bid.

Award - The acceptance by the Board of Supervisors of a bid.

Base Course - The layer or layers of specified or selected material of designed thickness placed on a subbase or a subgrade to support a pavement.

Basement Soils - That portion of the roadway in embankment areas below the design soil and to the bottom of the embankment or undercut, whichever is lower, and that portion of the earthwork in cut areas below the design soil and to the bottom of any undercut or other treatment required, whichever is lower.

Bidder - An individual, firm, partnership or corporation formally submitting a bid for the advertised work.

Binder Course - A combination of graded aggregate and bituminous material which constitutes the lower layer or layers of a flexible pavement, but not part of bituminous base or subbase course.

Board - The legally elected Board of Supervisors of the County who are responsible for the project and are shown as the party of the first part to the contract.

Borrow - Suitable material from approved sources outside the roadway prism, used primarily for embankments.

Box Bridge - A box culvert having a clear distance between inside face of the end supports exceeding 20 feet measured along the centerline of the roadway.

Bridge - A structure, including supports, erected over a depression or an obstruction, as water, highway, or railway, and having a track or passageway for carrying traffic or other moving loads and having a length measured along the center of the roadway of more than 20 feet between undercopings of abutments or extreme ends of openings for multiple boxes.

Bridge Length - The length of a bridge structure is the overall length measured along the line of survey stationing back to back of backwalls of abutments, if present, otherwise end to end of the bridge floor; but in no case less than the total clear opening of the structure.

Bridge Roadway Width - The clear width measured at right angles to the longitudinal centerline of the bridge between the bottom of curbs or railing.

Bridge Site - Unless otherwise specified in the contract, the bridge site shall be the entire area between the right-of-way lines and between lines paralleling the bridge ends and passing through the longitudinal extremities of the substructure or superstructure, whichever is greater.

Calendar Day - Any day shown on the calendar, beginning and ending at midnight.

Catastrophic Event - Slides, flooded major streams when such flood is determined to be in excess of the design stage; earthquakes, tornadoes, hurricanes, and other such disastrous phenomena of nature.

Commission - The Mississippi Transportation Commission.

Conformity - The degree of perfection required for the materials furnished and the work performed, and determined:

- (a) In the case of a "specified" value of a measurable characteristic, as set out in S-700.04.
- (b) In the case of a required "minimum" or "maximum" value of a measurable characteristic, as set out in S-700.04.
- (c) In the case of a required non-measurable characteristic, as being satisfactory to the Engineer.

Construction Change Request - An approved written order covering changes in the plans or quantities or both, within the scope of the contract, and establishing the basis of payment and time adjustments for the work affected by the changes.

Contract - The written agreement between the County Board of Supervisors, the Contractor and the State Aid Engineer setting forth the obligations of the parties thereunder, including but not limited to, the performance of the work, the furnishing of labor and materials, and the basis of payment.

The contract includes the invitation for bids, proposal, contract form and contract bond, specifications, supplemental specifications, general and detailed plans, special provisions, notices to bidders, and also any construction change requests and agreements that are required to complete the construction of the work in an acceptable manner, including authorized extensions thereof, all of which constitute one instrument.

Contract Bond - The approved form of security, executed by the Contractor and his Surety, guaranteeing complete execution of the contract and all supplemental agreements pertaining thereto and the payment of all legal debts pertaining to the construction of the project.

Contract Documents - All original or official papers relied upon as the basis, proof or support of the contract and shall include papers stated in the definition of the Contract.

Contract Time - The period of time, including authorized extensions, allowed for completion of the work under the contract.

Contract Unit Price - The price established in S-902-Proposal, or by Supplemental Agreement for a specifically described unit of work.

Contractor - The individual, firm, partnership or corporation contracting with the County Board of Supervisors for performance of prescribed work.

Controlling Work - The work or construction operations normally expected to be in progress as determined by the Engineer.

County - The county in which the work specified is to be performed.

Cross Slope - The rate of transverse slope in a roadbed element.

Culvert - Any structure not classified as a bridge which provides an opening under the roadway.

Department - The Mississippi Department of Transportation.

Design Grade - Design grade is any intermediate control grade at a vertical distance, as established on the typical section of the plans for the various intermediate courses, below profile grade.

Design Soil - That portion of the roadbed consisting of the top three feet of untreated or treated soils in excavated sections and embankments.

Detour - A designated existing route around a construction site.

Director - The Executive Director of the Mississippi Department of Transportation acting directly or through his authorized representatives.

Diversion - Temporary rerouting of traffic on a construction site.

Documentation - Written evidence recorded by an authorized individual of facts or conditions relating to a particular contractual matter.

Elements of Geometric Design - Those geometric elements of the highway which are defined in the "AASHTO Policy on Geometric Design" in effect at the time bids are received.

Engineer - The County/LSBP Engineer for each respective County, acting directly or through his duly authorized representatives, who is responsible for engineering supervision of the construction.

Equipment - All machinery and equipment, together with the necessary supplies for upkeep and maintenance, and also tools and apparatus necessary for the proper construction and acceptable completion of the work.

Executive Director - The Executive Director of the Mississippi Department of Transportation acting directly or through his authorized representatives.

Extra Work - An item of work not provided for in the contract as awarded, or an item of work provided for in the contract the nature or character of which is changed such as to justify a price adjustment, either of which is found essential in the satisfactory completion of the contract within its intended scope.

Extra Work Order - A CCR/SA concerning the performance of work or furnishing of materials involving extra work. Such extra work may be performed at contract prices or on a force account basis as provided elsewhere in these specifications.

Fixed Contract Unit Price - When the bid schedule of the proposal form indicates a fixed contract unit price (FCP), this price shall become the contract price for that item and shall be used in determining the total amount of the proposal.

Foreign Materials - Foreign materials are defined as being any material or manufactured product whose manufacturing process takes place outside the United States.

Hazardous Waste - Wastes that are regulated or "listed" under RCRA (40 CFR 261), or are ignitable, corrosive, reactive or toxic.

Highway, Street, or Road - A general term denoting a public way for purposes of vehicular travel, including the entire area within the right-of-way.

Holidays, Legal - In the State of Mississippi, holidays occur on:

January 1	New Year's Day
Third Monday in January	Robert E. Lee's and Dr. Martin Luther King, Jr.'s Birthday
Third Monday in February	Washington's Birthday
Last Monday in April	Confederate Memorial Day
Last Monday in May	National Memorial Day and Jefferson Davis' Birthday
July 4	Independence Day
First Monday in September	Labor Day
November 11	Armistice (Veterans') Day
Thanksgiving Day	As Proclaimed
December 25	Christmas Day

When a legal holiday falls on a Saturday or Sunday, the following Monday will be observed as a legal holiday.

Inspector - The Engineer's authorized representative assigned to make detailed inspections of contract performance.

Invitation for Bids - The advertisement for proposals for all work or materials on which bids are required. The advertisement will indicate with reasonable accuracy the quantity and location of the work to be done or the character and quantity of the material to be furnished and the time and place of the opening of proposals.

Laboratory - The testing laboratory of the Department or other approved testing laboratory which may be designated by the Engineer.

Legend - The words, letters and arrows, and other symbols shown on the plans and designated as legend, required to be placed on the surface of a pavement in the form of paint and glass beads, thermoplastic and glass beads or other similar specified materials, to serve as pavement markings.

Local Traffic - Traffic whose origin or destination is adjacent to that part of the project under construction.

Major and Minor Contract Items - A major item of work shall be defined as an item whose total monetary value, determined by multiplying the proposal quantity by the contract unit price, is equal to or greater than five percent of the original total contract amount. Unless otherwise specifically shown in the contract, all other items shall be considered minor items. Minor items shall become major items when increased to the extent that the total monetary value of such item at the original contract unit price is equal to or greater than five percent of the original total contract amount. A major item of work will remain a major item of work unless it is completely eliminated, or reduced by Supplemental Agreement for the purpose of substituting another item(s) in lieu thereof. When an item is eliminated, it shall be treated as provided for under S-109.05.

Materials - Any substances specified for use in the construction of the project and its appurtenances.

Notice to Bidders - All notices, issued to the prospective bidders, pertaining to or establishing requirements governing the submission of proposals, quantities or qualities of materials or work, the performance of the work, or payment therefor.

Notice to Contractors - Pre-bidding notices to prospective bidders, including the advertisement and other pertinent pre-bid information labeled as Notice to Contractors.

Notice to Proceed - Written notice to the Contractor to proceed with the contract work including, when applicable, the date of beginning of contract time.



Omitted Section - A section within the designated project limits in which no work (excluding construction signing, approaches and/or temporary connections) is to be performed, and the Contractor does not have any responsibility for maintenance of the roadway or traffic unless specifically provided of in the contract.

Optional Items - Items listed in the bid schedule of the proposal which are considered to be comparable for the purpose intended and from which the Contractor is not required to make a selection prior to or at the time of execution of the contract.

Pavement - The portion of the roadbed constructed upon the base course and specifically constructed as the contact element for vehicular traffic.

Pavement Structure - The combination of a pavement, a base course and, when specified, a subbase course, placed on a subgrade to support the traffic load and distribute it to the roadbed.

Pay Item - A specifically described unit of work for which a price is provided in the contract.

Plans - The approved plans, profiles, typical cross-sections, working drawings and supplemental drawings, or exact reproduction thereof, which show the location, character, dimensions, and details of the work to be done.

Profile Grade - The trace of a vertical plane intersecting the top surface of the proposed wearing surface as shown on the plans or established by the Engineer, usually along the longitudinal centerline of the roadbed. Profile grade means either elevation or gradient of such trace according to the context.

Project - The specific section of the highway together with the appurtenances and construction to be performed thereon under the contract.

Proposal - The offer of a bidder, on the prescribed form, to perform the work at the prices quoted.

Proposal Form - The approved form on which the Office of State Aid Road Construction requires bids to be prepared and submitted for the work.

Proposal Guaranty - The certified check, cashier's check or bid bond furnished with the bid to guarantee that the bidder will enter into a contract for the work and furnish acceptable bond if his bid is accepted.

Qualified prison facility - Any prison facility in which convicts, during the 12 month period ending July 1, 1987, produced materials for use in Federal Aid highway construction projects.

Retainage - A general term denoting funds withheld from partial payments.

Right-of-Way - A general term denoting land, property, or interest therein, usually in a strip, acquired for or devoted to a highway and its appurtenances.

Roadbed - The graded portion of a highway within top and side slopes prepared as a foundation for pavement structure and shoulders.

Roadside - A general term denoting the area adjoining the outer edge of a roadway.

Roadside Development - Those items necessary to the complete highway which provide for the preservation of landscape materials and features; the rehabilitation and protection against erosion of all areas disturbed by construction through seeding, sodding, mulching and the placing of other ground covers; and such suitable planting, other improvements and public facilities as may increase the effectiveness and usefulness and enhance the appearance of the highway.

Roadway - All surface portions of the highway between shoulder lines. Divided highways are considered to have two roadways.

Roadway Structure - All vertical and horizontal elements of the work, exclusive of bridges, designed to provide and support the roadway.

Shoulders - The portion of the roadway contiguous with the traveled way for the lateral support of the other elements of the pavement structure, and for emergency use of stopped vehicles.

Sidewalk - That portion of the road, highway, or street primarily constructed for use by pedestrians.

Special Provisions - Additions and revisions to the standard and supplemental specifications covering conditions peculiar to an individual project, and included in the proposal assemblies.

Specifications - A general term applied to all directions, provisions and requirements pertaining to performance of the work or materials to be used.

Standard Operating Procedures - The Office of State Aid Road Construction Standard Operating Procedures are the rules, regulations, instructions and policies, promulgated by the State Aid Engineer acting through his authorized representatives, which are required to effectively accomplish the statutory responsibilities of the Office of State Aid Road Construction and which are compiled in volumes, distributed to all County/LSBP Engineers, and on file at the office of the State Aid Engineer.

State - The State of Mississippi acting through its authorized representative.

State Aid Engineer - The State Aid Engineer, appointed by the Governor of the State of Mississippi acting directly or through a duly authorized representative.

Structures - Bridges, culverts, catch basins, drop inlets, retaining walls, cribbing, manholes, endwalls, buildings, sewers, service pipes, underdrains, foundation drains, and similar features which may be required in the work.

Subbase Course - The layer(s) in the pavement structure between the design soil and the base course. Treated portions of the design soil may be considered as subbase or a portion thereof when its treatment or stabilization is sufficient to adequately improve the bearing value.

Subcontractor - An individual, firm, partnership or corporation to whom the Contractor, with the written consent of the Board and the State Aid Engineer, sublets part of the contract.

Subgrade - The top surface of a design soil upon which the pavement structure and shoulders are constructed.

Substructure - Those parts of a bridge below the bearings of simple and continuous spans, below the bottom surface of concrete box girder spans in which the piers form an integral part of the span-pier entity, or below wingwalls of abutments.

Superintendent - The Contractor's authorized representative in responsible charge of the work.

Superstructure - All parts of a bridge above and exclusive of the substructure.

Supplemental Agreement - A written agreement by the parties of the contract covering alterations or extra work necessary for the completion of the contract.

Supplemental Specification - Additions and revisions to the Standard Specifications that are adopted subsequent to issuance of the printed book.

Surety - The corporate body, qualified under the laws of Mississippi, which is bound with and for the successful bidder by the "bid bond" to execute a satisfactory contract with and for the Contractor for the acceptable performance of the contract and for his payment of all legal taxes and debts pertaining to the construction of the project, including payment of State Sales Tax as prescribed by law.

Temporary Structures - Structures required to maintain traffic while the Contractor constructs structures. The temporary structure shall include the earth approaches thereto unless otherwise specified.

The Work - The furnishing of all labor, materials, equipment, and incidentals necessary to the successful completion of the project and the carrying out of the duties and obligations imposed by the contract.

Titles (or Headings) - The titles or headings of the sections and subsections herein are intended for convenience of reference and shall not be considered as having any bearing on their interpretation.

Township, Town, City or District - A subdivision of the County used to designate or identify the location of the proposed work.

Traveled Way - A portion of the roadway improved, designed or ordinarily used for vehicular travel, exclusive of shoulders or berms.

Work Order - A written order, signed by the Engineer, of a contractual status requiring performance by the Contractor without negotiation of any sort.

Working Day - A calendar day, exclusive of the days listed below, on which weather and soil conditions are such that the Contractor can proceed with construction for seven (7) consecutive daylight hours with normal working forces engaged in performing the controlling work which would be in progress at that time. Excluded days are:

1. Saturdays
2. Sundays
3. State recognized legal holidays
4. Days on which delays are attributable to:
  - (a) The County or State
  - (b) Governmental Authorities
  - (c) Catastrophic events
  - (d) Awaiting growth and coverage of planted vegetation, waiting for prime or concrete to cure, or other specific conditions set out elsewhere in the contract

State recognized legal holidays are as set out in this Subsection. When a legal holiday falls on a Saturday or Sunday, the following Monday will be observed as a legal holiday.

The controlling work will be determined after careful consideration of the Contractor's operation(s) of construction that normally should be in progress at that time, as essential to the orderly completion of the work within the time allowed.

The acceptance of any progress payment accompanying any estimate, without written protest, shall be acknowledgment by the Contractor that the number of working days shown on the estimate are correct. The number of working days shall be indicated in the proposal and counted from the designated date for beginning work or date work actually began, whichever occurs first, to the date of final acceptance.

Working Drawings - Stress sheets, shop drawings, erection plans, falsework plans, framework plans, cofferdam plans, bending diagrams for reinforcing steel, or any other supplementary plans or similar data which the Contractor is required to submit to the Engineer for approval.

**S-101.03.** Whenever in these specifications terms not defined herein are used to identify geometric elements of the work, such terms shall be understood to have the meaning as established by AASHTO, and current at the time bids are received.

**S-101.04--Presumption.** To avoid repetition of expressions, it is provided that any directive, action or opinion that is not so denoted shall be understood to be followed by the words "by the Engineer" or "to the Engineer."

**S-102.00--Advertisement.** In conformity with State law, the Board will publish a Notice to Contractors giving notice of a request for bids. This notice will become one of the contract documents if award is made.

The advertisement will state the time and place for submission of sealed proposals; the location and description of the proposed work; estimates of the quantities and kinds of work to be performed or materials to be furnished and a schedule of pay items for which unit bid prices are asked; specified contract time; and instructions to bidders regarding proposal forms, basis of award, proposal guaranty required, plans, specifications, labor requirements, supplemental specifications and/or special provisions, and other pertinent information. Proof of publication of advertisement shall be available at the time of opening of bids.

**S-102.01--Prequalification of Bidders.** Information may be required from time to time from prospective bidders before issuing proposals.

The attention of prospective bidders is directed to all fees and taxes required for the privilege of doing business within the State.

As a condition precedent to the opening of a bid financed wholly with State funds and which is equal to or in excess of 50,000 dollars, the bidder must have a Certificate of Responsibility issued by the Mississippi State Board of Contractors and the certificate number must be shown on the outside of the sealed envelope containing the bid proposal. When a bid is less than 50,000 dollars, a Certificate of Responsibility is not required but either the statement, "Bid less than 50,000 dollars" or a certificate number must be shown on the envelope.

In addition, prospective bidders are reminded of the requirements set forth by the Mississippi State Board of Public Contractors that the classification of a contractor, as registered with the Board, must be the same as the nature of the proposed work on which the bid will be submitted.

When two or more persons, firms, partnerships or corporations are submitting a joint proposal, each of the persons, firms, partnerships or corporations may be required to comply with the above prequalification requirements.

**S-102.02--Contents of Proposal Forms.** The proposal forms will state the location and description of the contemplated construction, will show estimates of the quantities and kinds of work to be performed or materials to be furnished, and will have a schedule of items for which unit bid prices are invited.

The proposal form will state the time in which the work must be completed, the amount of the proposal guaranty, and the date, time and place of the opening of proposals. The form will also include supplemental specifications and/or special provisions and requirements which vary from or are not contained in the Standard Specifications.

All papers bound with, attached to, or designated for addition or substitution in the proposal form are considered a part thereof and must not be detached or altered when the proposal is submitted.

The plans, specifications and other documents designated in the proposal form shall be considered a part of the proposal as if attached to and included in the proposal form.

Plans and specifications for any project(s) identified in an Advertisement will be on file in the offices of the County Engineer.

Prospective bidders will obtain proposals and plans from the County Engineer. Cost and other general information concerning the proposal and plans will be as contained in the Notice to Contractors published by the Board.

**S-102.03--Issuance of Proposal Form.** The Board reserves the right to refuse to furnish a prospective bidder with a proposal form for any of the following reasons:

- (a) Lack of competency and adequate machinery, plant, or other equipment, as revealed by the information obtained as provided in S-102.01 or other determinations made by the Board.
- (b) Uncompleted work which, in the judgment of the Board and State Aid Engineer, might hinder or prevent the prompt completion of additional work if awarded.
- (c) Failure to pay, or satisfactorily settle, all bills due for labor and materials on former contracts in force at the time of issuance of proposals.
- (d) Unsatisfactory performance on previous contracts.
- (e) Failure to promptly reimburse the Board for any overpayment that might have occurred.

- (f) Actions in bidding or subcontracting which have the effect of limiting competition and violating the competitive bid process; or if any partner, association member, corporate official or individual owner, respectively, has been convicted or entered a plea of guilty or nolo contendere in any legal jurisdiction of the United States or any of the various states of federal or state crimes that involve the restraint of trade or limiting competition in any manner, or has been debarred from bidding on public contracts by the State of Mississippi or any of its agencies; or by one or more of the other States or any of their agencies; or by a federal agency.

**S-102.04--Interpretation of Quantities in Bid Schedule.** The quantities appearing in the bid schedule are approximate only and are prepared for the comparison of bids. Payment to the Contractor will be made only for the actual quantities of work performed and accepted or materials furnished and accepted in accordance with the contract. The scheduled quantities of work to be done and materials to be furnished may each be increased, decreased, or omitted as hereinafter provided.

**S-102.05--Examination of Plans, Specifications, Special Provisions, Notices to Bidders and Site of Work.** It is the intent that the Engineer will prepare full, complete, and accurate plans and specifications giving directions that will enable any competent Contractor to carry them out. The bidder is expected to examine carefully the site of the proposed work, the proposal, plans, specifications, supplemental specifications and/or special provisions, notices to bidders and contract forms before submitting a proposal. The submission of a bid shall be considered prima facie evidence that the bidder has made such an examination and is satisfied as to the conditions to be encountered in performing the work and as to the requirements of the plans, specifications, supplemental specifications, notices to bidders, special provisions, contract, and the Federal, State, and local laws which will in any way affect his execution of the work.

Boring logs and other records of subsurface investigations may be available for inspection by bidders. It is understood that such information was obtained and is intended for design and estimating purposes only. It is made available to bidders so that they will have access to identical subsurface information available to the Board and Office of State Aid Road Construction and is not intended as a substitute for personal investigation, interpretations and judgment of the bidders.

Bidders may inspect records of the Engineer and Office of State Aid Road Construction as to investigations made, subject to the conditions hereinbefore set forth.



**S-102.06--Preparation of Proposal.** The bidder shall submit his proposal on the forms furnished by the Office of State Aid Road Construction and shall enter in figures a unit price and extension in the appropriate columns for each bid item exclusive of those items for which a fixed contract unit price and the extension are shown. The bidder shall also enter where indicated the subtotal amount for each of the various divisions and the total amount of the proposal which shall also include the extensions of the items with a fixed contract unit price. In case of discrepancy between a unit price and the extension, the unit price will govern; and the extension and the total amount of the proposal will be corrected. All the figures shall be in ink or typed.

When the bid schedule contains a fixed contract unit price (FCP) for an item, this price shall be the contract unit price for the item and no alteration shall be made by the bidder.

When an item in the proposal contains a choice to be made by the bidder, the bidder shall indicate his choice in accordance with the instruction to bidders in Section S-902 - Proposal (reference is made to Alternate Designs, Alternate Items, and Optional Items in S-101.02).

Where the bid schedule lists alternate designs or alternate items, one alternate that is bid shall be designated by drawing a line or lines through other listed alternate(s) as provided, and thereafter no further choice will be permitted.

When the bid schedule lists optional items, the Contractor may, but is not required to, make his selection at the time of bidding or prior to or at the time of execution of the contract. It shall be the Contractor's responsibility to provide notice of selection to the County Engineer and the State Aid Engineer sufficiently in advance to provide a reasonable time for the exchange of the documentation for selection prior to ordering materials or performing work on any optional item.

Each proposal issued to prospective bidders will contain, in duplicate, blank affidavit forms to be executed, and sworn to, by the bidder, before a person who is authorized by the laws of any State to administer oaths, and returned with the bidder's proposal.

This "Non-Collusion Affidavit" shall be a sworn statement, filed in duplicate, executed by, or on behalf of, the individual, firm or corporation to whom the contract is to be awarded (if the successful bidder), certifying that such individual, firm, or corporation has not, directly or indirectly, entered into any agreement, participated in any collusion, or otherwise taken any action in restraint of free competitive bidding in connection with such contract nor have any of its officers, partners, employees, or principal owners; and that such individual, firm or corporation nor any of its directors, officers, partners, principal owners or managerial employees are debarred from bidding on public contracts by the State of Mississippi or any of its agencies; or by one or more of the other States or any of their agencies; or by a federal agency.

Failure on the part of the bidder to execute the affidavit will result in his proposal being declared incomplete and rejected.

The bidder's proposal must be signed in ink by the individual, by one or more members of the partnership, by one or more members or officers of each firm representing a joint venture, or by one or more officers of a corporation, or by an agent of the Contractor legally qualified and acceptable to the State. If the proposal is made by an individual, his name and post office address must be shown; by a partnership, the name and post office address of each partnership member must be shown; as a joint venture, the name and post office address of each member or officer of the firms represented by the joint venture must be shown; by a corporation, the name of the corporation and the business address of its corporate officials must be shown.

The address stated by the bidder on his proposal shall be his permanent address, unless changed by him by written notice to the Board and the State Aid Engineer, and all notices to the Contractor provided for in the contract shall be considered as given or delivered to the Contractor when mailed or delivered to that address by the Engineer or Office of State Aid Road Construction.

**S-102.07--Irregular Proposals.** Proposals will be considered irregular and may be rejected for any of the following reasons:

- (a) If the proposal is on a form other than that secured from the Engineer, or if the form is altered or any part thereof is detached.
- (b) If there are unauthorized additions, conditional or alternate bids, or irregularities of any kind which may tend to make the proposal incomplete, indefinite, or ambiguous as to its meaning.
- (c) If the bidder adds any provisions reserving the right to accept or reject an award, or to enter into a contract pursuant to an award.
- (d) If the proposal does not contain a unit price for each pay item listed except in the case of alternate or optional pay items.
- (e) If the proposal, Section S-902, does not contain acknowledgment of receipt and addition to the proposal and contract documents of all addenda issued prior to opening of bids.
- (f) Failure to execute required affidavits, certificates, etc., and furnish proposal guaranty.

**S-102.08--Proposal Guaranty.** Proposals will not be considered unless accompanied by certified check, cashier's check or bid bond, made payable to the County and the State of Mississippi, in an amount of not less than five percent of the total amount of the proposal offered, as evidence of good faith and as a guaranty that if awarded the contract, the bidder will execute the contract and give contract bond as required by law and stipulated in S-103.05.

If a bid bond is offered as guaranty, the bond must be on a form approved by the State Aid Engineer, made by a Surety, and must be acceptable to the Board and the State Aid Engineer and signed or countersigned by a qualified Mississippi resident agent and the bidder.

**S-102.09--Delivery of Proposal.** Unless otherwise specified, each proposal must be submitted sealed in a plain envelope with the following listed information plainly written on the outside or face of the envelope:

- (1) Addressee: Board of Supervisors of \_\_\_\_\_ County.
- (2) Bid of: Name of Person or Firm submitting the bid.
- (3) Permanent address of the Bidder: Post Office Box Number, or Street Address, and the City and State of the Bidder.
- (4) For: Project Number\_\_\_\_\_ County of\_\_\_\_\_.
- (5) Date of Submission of Bid.
- (6) Bidders Certificate of Responsibility Number issued by the Mississippi State Board of Public Contractors.

Proposal forms when issued, by the Engineer, are not transferable and no name or names of interested parties may be added other than those to whom the proposal was issued.

The County Engineer will keep a list of the bidders to whom proposals have been issued and bids will be accepted only under the name of the bidders issued proposals.

No proposal will be accepted or considered which has not been received at the office of the Board prior to the time specified in the Notice to Contractors.

**S-102.10--Withdrawal or Revision of Proposals.** A bidder may withdraw or revise a proposal after it has been deposited with the Board, provided the request for such withdrawal or revision is received by the Board, by facsimile, in writing or by telegram, before the time set for opening proposals.

**S-102.11--Combination or Conditional Proposals.** If the Board and State Aid Engineer so elects, proposals may be issued for projects in combination or separately, so that bids may be submitted either on the combination or on separate units of the combination. The Board and State Aid Engineer reserves the right to make awards on combination bids or separate bids to the best advantage of the Board. No combination bids, other than those specifically set up in the proposals by the Board and State Aid Engineer, will be considered. At the discretion of the Board and State Aid Engineer, separate contracts may be written for each individual project included in the combination.

Conditional proposals will be considered when so stated in the special provisions.

**S-102.12--Public Opening of Proposals.** Proposals will be opened and read publicly at the time and place indicated in the proposal. Bidders, their authorized agents, and other interested parties are invited to be present.

**S-102.13--Disqualification of Bidders.** Either of the following reasons may be considered as being sufficient for the disqualification of a bidder and the rejection of his proposal or proposals:

- (a) More than one proposal for the same work from an individual, firm, or corporation under the same or different names.
- (b) Evidence of collusion among bidders. Participants in such collusion will receive no recognition as bidders for any future work in any County until any such participant shall have been reinstated as a qualified bidder.

**S-102.14--Material Guaranty.** At the option of the Board or State Aid Engineer, the successful bidder shall be required at any time before or after the award or execution of the contract to furnish a complete statement of the origin, composition, and manufacture of any and all materials to be used in the construction of the work, and shall provide the County and State with access to all sources of materials for sampling and testing to determine their quality, uniformity, and fitness for the work in accordance with the contract.

**S-103.01--Consideration of Proposals.** After the proposals are opened and read, they will be compared on the basis of the summation of the products of the approximate quantities shown in the bid schedule by the unit prices bid. The results of comparisons will be immediately available to the public. In the event of a discrepancy between unit prices and extensions, the unit price shall govern.

In consideration of contract proposals which are equal to or in excess of 50,000 dollars and financed wholly with State funds, preference will be given to resident Contractors, and a nonresident bidder domiciled in a state having laws granting preference to local Contractors will be considered for such contracts on the same basis as the nonresident bidder's State awards contracts to Mississippi Contractors bidding under similar circumstances.

When a nonresident Contractor submits a bid equal to or in excess of 50,000 dollars and the contract is financed wholly with State funds, the Contractor shall attach thereto a copy of the current laws from the State of domicile and an explanation thereof pertaining to treatment of nonresident Contractors. If no preferential treatment is provided for resident Contractors in the State of domicile and contracts are awarded to the lowest responsible bidder, a statement to this effect shall be attached. Should the attachment not accompany the bid when submitted, the Contractor shall have 10 days following the opening of bids to furnish the information to the Engineer.

As used herein, the term "resident Contractors" includes a nonresident person, firm, or corporation that has been qualified to do business in this State and has maintained a permanent full-time office in the State of Mississippi for two years prior to January 1, 1986, and the subsidiaries and affiliates of such a person, firm or corporation.

The right is reserved to reject any or all proposals, to waive technicalities, or to advertise for new proposals, if in the judgment of the awarding authority the best interests of the County will be promoted thereby.

**S-103.02--Award of Contract.** The award of contract, if awarded, will be made within 60 calendar days after the opening of proposals to the qualified bidder whose proposal complies with all the requirements prescribed. The award of contracts involving the expenditure of Federal funds will be contingent upon approval of the State Aid Engineer and the Executive Director of the Mississippi Department of Transportation. The successful bidder will be notified, by letter mailed to the address shown on his proposal, that his bid has been accepted and that he has been awarded the contract.

Resident Contractors actually domiciled in Mississippi which may be corporate, individuals or partnerships are to be granted preference over nonresidents in awarding of contracts in the same manner and to the same extent as provided by the laws of the State of domicile of the nonresident.

**S-103.03--Cancellation of Award.** The Board and the State Aid Engineer reserve the right to cancel the award of any contract at any time before the execution by all parties without liability against either party.

**S-103.04--Return of Proposal Guaranty.** Bid bonds will not be returned.

Certified checks or cashier's checks submitted as proposal guaranties, except those of the two lowest bidders, will be returned immediately following the opening and checking of the proposals. The retained proposal guaranty of the unsuccessful of the two lowest bidders will be returned within ten days following the award of contract, and that of the successful bidder will be returned after a satisfactory contract bond has been furnished and the contract has been executed.

In the event no award is made within 15 days after the opening of bids, the Board and State Aid Engineer may permit the successful bidder to substitute a satisfactory bidder's bond as a guaranty in lieu of certified check or cashier's check submitted with his proposal.

Should no award be made within 60 calendar days, all proposals will be rejected and all proposal guaranties returned, unless the lowest responsible bidder, at the request of the Board and State Aid Engineer agrees in writing to a longer delay.

**S-103.05--Requirement of Contract Bond.** Prior to the execution of the contract, the successful bidder shall execute and deliver to the Board a contract bond or bonds in a sum equal to the full amount of the contract. In the event of award of a joint bid, each individual, firm, or corporation shall assume jointly the full obligations under the contract and contract bond. The form of the bond or bonds shall be that provided by or acceptable to the State Aid Engineer. The bond or bonds shall be negotiated for, procured from, signed or countersigned by, and the premium paid to a qualified Mississippi resident agent of the Surety. (Reference is made to Sections 31-5-1 and 31-5-3, Mississippi Code 1972, Annotated, and other State statutes applicable thereto).

**S-103.06--Liability Insurance.**

**S-103.06.1--General.** The Contractor shall carry public liability and property damage liability insurance of limits not less than: bodily injury --\$100,000 each person, \$200,000 each occurrence; property damage --\$50,000 each occurrence \$250,000 aggregate; automobile liability insurance--\$100,000 each person, \$200,000 each occurrence for bodily injury, and \$50,000 property damage. Each policy shall be signed or countersigned by a Mississippi resident agent of the insurance company.

On projects funded totally with State and/or County funds, the Contractor shall carry contractor's liability (including subcontractors and contractual) with limits not less than: \$300,000 each occurrence; \$1,000,000 aggregate; automobile liability - \$500,000 combined single limit - each accident; Workers' Compensation and Employers' Liability - Statutory & \$100,000 each accident; \$100,000 each employee; \$500,000 policy limit.

Each policy shall be signed or countersigned by a Mississippi Resident Agent of the insurance company.

The Contractor shall have certificates furnished to the Board and the State Aid Engineer from the insurance companies providing the required coverage. The certificates shall be on a form acceptable to the State Aid Engineer and show the types and limits of coverage. The State Aid Engineer may request duplicate or certified copies of the policies.

**S-103.06.2--Railroad Protective.** The following provisions are applicable to all work performed under a contract on, over or under the rights-of-way of each railroad shown on the plans.

The Contractor shall assume all liability for any and all damages to his work, employees, servants, equipment and materials caused by railroad traffic.

Prior to starting any work on railroad property, the Contractor shall furnish satisfactory evidence to the Board and the State Aid Engineer that insurance of the forms and amounts set out herein in paragraphs (a), (b) and (c) have been obtained. Also, the Contractor shall furnish similar evidence to the Railroad Company that insurance has been obtained in accordance with the Standard Provisions for General Liability Policies and the Railroad Protective Liability Form as published in the Code of Federal Regulations, 23 CFR 646, Subpart A. Evidence to the Railroad Company shall be in the form of a Certificate of Insurance for coverages required in paragraphs (b) and (c), and the original policy of the Railroad Protective Liability Insurance for coverage required in paragraph (a).

All insurance herein specified shall be carried until the contract is satisfactorily complete as evidenced by a release of maintenance from the Board and the State Aid Engineer.

The Railroad Company shall be given at least 30 days notice prior to cancellation of the Railroad Protective Liability Insurance policy.

For work within the limits set out in this subsection, the Contractor shall provide insurance for bodily injury liability, property damage liability and physical damage to property with a combined amount of \$2,000,000 per occurrence and an aggregate of \$6,000,000 applying separately to each annual period for each of (a), (b) and (c) as set out herein. Bodily injury shall mean bodily injury, sickness, or disease, including death at anytime resulting therefrom. Property damage shall mean damages because of physical injury to or destruction of property, including loss of use of any property due to such injury or destruction. Physical damage shall mean direct and accidental loss of or damage to rolling stock and their contents, mechanical construction equipment or motive power equipment.

- (a) Railroad Protective Liability Insurance shall be purchased on behalf of the Railroad Company by the Contractor. When applicable, AMTRAK shall be included as an additional insured.

- (b) Regular Contractor's Public Liability and Property Damage Insurance, including XCU and automobile, issued in the name of the Contractor shall be so written as to furnish protection to the Contractor respecting the Contractor's operations in performing work covered by the contract. Coverage shall include protection from damages arising out of bodily injury or death and damage or destruction of property which may be suffered by persons other than the Contractor's own employees.
- (c) When the Contractor sublets a part of the work to a Subcontractor, the Contractor shall secure insurance protection in their own behalf under Contractor's Protective Public Liability and Property Damage Insurance, including XCU and automobile, to cover any liability imposed on them by law for damages because of bodily injury or death and damage or destruction of property as a result of work undertaken by a Subcontractor.

**S-103.07--Execution and Approval of Contract.** The successful bidder to whom the contract has been awarded shall sign and file with the Board and State Aid Engineer the contract and all documents required by the contract within 15 days after the contract has been mailed to the bidder. If the contract is not executed by the Board and approved by the State Aid Engineer within 15 days following receipt from the bidder of the signed contract and all necessary documents required by the contract, the bidder shall have the right to withdraw his bid without penalty. No contract shall be considered as effective until it has been fully executed by all parties thereto.

**S-103.08--Failure to Execute Contract.** Failure to execute the contract and file acceptable bond within 15 days after the contract has been mailed to the bidder shall be just cause for the cancellation of the award and the forfeiture of the proposal guaranty which shall become the property of the Board, not as a penalty, but in liquidation of damages sustained. Award may then be made to the next lowest responsible bidder, or the work may be readvertised, at the discretion of the Board and the State Aid Engineer.



**S-104.01--Intent of Contract.** The intent of the contract is to provide for the execution, construction, and completion of every detail of the work described, and to compensate the Contractor for all acceptable work done in accordance with the provisions of the contract. The Contractor shall furnish all labor, materials, equipment, supplies, transportation, supervision, methods, and procedures necessary to complete the work in accordance with the plans, specifications, and terms of the contract.

**S-104.02--Alterations of Plans or Character of Work.** The Board and State Aid Engineer reserve the right to make, at any time during the progress of the work, increases or decreases in quantities and alterations in the details of construction, including alterations in the grade or alignment of the road or structure or both, as may be found necessary or desirable. Such increases or decreases and alterations shall neither invalidate the contract nor release the Surety, and the Contractor agrees to perform the work as altered, the same as if it had been a part of the original contract.

Except as may be necessary to satisfactorily complete the contract, no alterations of the plans or the nature of the work will involve work beyond the termini of the contemplated construction without contract modifications approved by all parties concerned.

Except as provided herein, all quantities will be paid for at the contract unit price (reference is made to S-109.03).

No claim shall be made by the Contractor for any loss of anticipated profit because of such alterations, or by reason of any variation between the approximate quantities and the quantities of work done.

Unless otherwise provided, Supplemental Agreements will be required under the following conditions:

- (1) When the total amount of any increase or decrease, whether applying to one or more than one item, exceeds in value twenty-five percent (25%) of the total Contract amount as determined by the total sum of the estimated values in the Contract proposal. Those items, the quantities for which cannot be pre-determined with reasonable accuracy, such as rock excavation, extra depth excavation, extra depth concrete and reinforcing steel for same, shall be excluded in determining increases or decreases under this provision.
- (2) When there is lengthening or shortening of the project.
- (3) When the character or nature of the work is materially altered.
- (4) When there is a substitution of one type of material for another type of material. (Contract items found not necessary for the proper completion of the work will be eliminated from the Contract as set out in Subsection S-109.05.)

- (5) When there is a change of quantities of sufficient magnitude to cause an inequity on the Contractor or the Board.

**S-104.02.1--Changes in Character of the Work and Changed Physical Conditions.**

Should any change ordered, exclusive of changes in contract quantities, alter the characteristics of the original contract; or should subsurface or latent physical conditions be discovered by the Engineer or encountered by the Contractor at the site of the work that differ materially from those originally encountered in and generally recognized as usual in work of the character provided for in the contract; and the changes or conditions are of sufficient magnitude to cause an inequity on the Contractor or on the Board, the Engineer or the Contractor, as the case may be, shall promptly notify the other in writing of these changes or conditions before work is continued. The State Aid Engineer may thereupon provide for an adjustment of the contract unit price or contract time if an engineering study warrants that the changes or conditions do so materially differ and cause inequity.

Before beginning or continuing work which justifies an adjustment of the contract unit price or time under the above provisions, a supplemental agreement acceptable to all parties to the contract shall be executed. In the event an agreement acceptable to all parties cannot be reached, the State Aid Engineer may order the work to proceed in accordance with the applicable specifications and as directed, and that part of the work which the State Aid Engineer has determined to justify an adjustment of the contract unit price or the establishment of a unit price will be paid for in accordance with S-109.04.

If the altered or added work is of a character as to require more than the normal time to complete the work, an adjustment of the contract time may be made in accordance with the provisions of S-108.06.

A net total increase or decrease of more than 25 percent in the total original contract amount may be considered for adjustment under this subsection, in lieu of the otherwise applicable provisions of S-104.02.

**S-104.03--Extra Work.** The Contractor shall perform unforeseen work for which there is no price included in the contract or work included in the contract which is materially changed as set out in S-104.02 after execution of the contract, whenever it is deemed necessary or desirable in order to complete fully the work as contemplated. Such work shall be performed in accordance with the applicable specifications and as directed, and payment or adjustment in payment will be made as provided under S-109.04.

**S-104.04--Maintenance of Traffic.** The responsibility for the construction and maintenance of detour routes and or diversions shall be as indicated herein unless amended by special provisions.

The implementation of traffic control shall be in accordance with the traffic control plan, which includes the plans, specifications, special provisions and the MUTCD.

Unless otherwise indicated all detour routes shall be maintained by the Board. The Contractor will be required to provide and satisfactorily maintain on site diversions, as determined by the Engineer. Ingress and egress for residents adjacent to the improvement, U. S. Mail Carrier and school buses on official business shall be provided throughout construction. Where necessary, the Contractor will remove and replace mail boxes.

In case it is necessary or desirable to maintain through traffic on the road during construction it will be set out in the special provisions.

Special maintenance directed by the Engineer, for the benefit of the traveling public, will be paid for on the basis of the contract unit prices or under S-104.03, Extra Work. The Engineer will be the sole judge of work to be classified as Special Maintenance.

**S-104.05--Removal and Disposal of Structures and Obstructions.** The Contractor shall remove and dispose of all existing structures and obstructions in accordance with the provisions of S-202. In the event separate pay items are not provided, the cost of removal and disposal shall be included in prices bid for items under S-201 and S-203.

The Contractor shall not remove or disturb any buildings, public utilities, or other public or private improvements that are to be removed and replaced or reconstructed by the Board or by the owners under separate agreement.

It is anticipated that obstructions to be removed by the Board or the owners will be removed and disposed of in advance of construction operations, but in the event there are improvements or other properties on the project retained by the property owner, the Contractor shall not interfere with this property until notified in writing by the Engineer that the rights of the property owner have expired.

Delays in the work occasioned by removal or non-removal by the owner will be considered as attributable to the State under the provisions of the contract for the determination and extension of contract time.

Upon notification by the Engineer that the property owner's rights have expired, the Contractor shall proceed to remove and dispose of structures and obstructions in accordance with this subsection and other applicable provisions of the contract.

Principal existing improvements not reserved to the property owner or to the County and which are to be removed by the Contractor will be indicated on the plans for the Contractor's information only.

All other structures and obstructions or residual portions of existing structures and obstructions not specified to remain are also to be removed by the Contractor.

All removals by the Contractor are to be made in accordance with the provisions of S-201, and, by reference therein, S-202.

**S-104.06--Rights in and Use of Materials Found on the Work.** It is understood that title to all materials found within the right-of-way or easements remains with the County unless specifically noted on the plans or in the contract documents. However, the Engineer may permit the Contractor to use on the project stone, gravel, and sand or other material found in the excavation that may be determined suitable and useful in fulfillment of the contract requirements. The Contractor will be paid both for the excavation of the materials at the contract unit price for excavation and for the pay item for which the excavation material is acceptably used. He shall replace at his own expense with other acceptable material all of the excavation material needed for use in embankments, backfills, approaches, or otherwise in the work. No charge for the material so used will be made against the Contractor. The Contractor shall not excavate or remove any material from within the highway location which is not within the grading limits established by slope stakes without prior written authorization from the Engineer. The Contractor will not be paid for excavation outside the grading limits without prior authorization.

Unless otherwise provided, material from existing structures required to be removed may be used temporarily by the Contractor. Material designated to be salvaged shall not be cut or otherwise damaged.

When the contract documents indicate that certain materials or other matter are to be removed, or are permitted to be removed from the right-of-way and disposed of at locations provided by the Contractor, the Contractor shall furnish the Engineer with two signed copies of a release from each property owner for the servitude of his lands prior to removal. The Board will have no ownership or liability whatsoever for the materials or matter upon removal from the right-of-way.

**S-104.07--Final Cleaning Up.** Without any extra compensation and before acceptance and final payments will be made, the right-of-way, borrow pits and adjacent property, and all other grounds occupied or affected by the Contractor in connection with the work shall be cleaned of all rubbish, temporary buildings and structures, equipment, and excess materials. Salvaged or excess materials expressly reserved by the Engineer for use by the County shall be neatly stockpiled at locations designated on the project. The Contractor shall restore, repair, or settle for in an acceptable manner all property, both public and private, which he may have damaged in the prosecution of the work. The Contractor shall leave all public or private property occupied or affected by him and all parts of the work in a neat and acceptable manner with all waterways unobstructed. This shall include, but not necessarily be limited to, the cleaning out of all pipe and ditches, and the removal from the right-of-way all debris from clearing and grubbing.

Prior to final inspection or release from maintenance, all sod turf areas of the work which have developed an undesirable growth shall be given a final mowing. All undesirable bushes, high grasses, and weeds shall be cut and disposed of as directed.

Where construction involves only base and/or surfacing, the Contractor shall be required to mow between ditch lines in cut sections and down the fill slope for a distance of 10 feet measured horizontally from the edge of the shoulder through fill sections.

**S-104.08-Value Engineering Incentive.** Value Engineering Incentive applies to any cost reduction recommendation initiated and developed by the Contractor for the purpose of refining the contract documents and plans so as to contribute to design cost effectiveness or significantly improve the quality of the final product. This subsection does not apply unless the recommendation is identified by the Contractor at the time of submission as a Value Engineering Incentive. The Board and the State Aid Engineer shall be the judge of the acceptability of any such recommendation.

Cost reduction recommendations approved by the Board and State Aid Engineer are to be implemented by a supplemental agreement to the contract and must result in savings without impairing any essential functions and characteristics such as safety, service life, reliability, economy of operations, ease of maintenance, aesthetics and necessary standard design features. Proposed changes in the basic design requirements of a bridge or of a pavement system will not normally be given consideration as a Value Engineering Incentive. The mere substitution of one contract bid item for another bid item or substitution of any other item for which the Engineer has previously established a pay item will not be allowed as value engineering nor will a submittal based on the use of material from the right-of-way.

As a minimum, the following information shall be submitted by the Contractor:

- (a) A statement that the recommendation is submitted as a Value Engineering Incentive.
- (b) Description of the recommendation.
- (c) Discuss contract requirements which will require modification and present a recommendation for each change.
- (d) An estimate of cost reductions.
- (e) Prediction of any effects on other costs to the project.
- (f) State when the supplemental agreement must be executed to obtain maximum cost reduction during the remainder of the contract and the reasons therefor.
- (g) A statement as to any effect on the project completion date.

The County will not be liable for any delay in acting upon a recommendation. The decision of the Board and State Aid Engineer as to acceptance of any such recommendation will be final and not subject to S-105.17. The Board and State Aid Engineer may accept the recommendation, in whole or in part, by executing a supplemental agreement which will specifically state that it is executed pursuant to these provisions. Such agreement will incorporate the changes or additions to the plans and specifications which are necessary to permit the recommendation, or accepted part thereof, to be put into effect. If conditional, it will include conditions upon which the Board and State Aid Engineer's approval is based. The agreement will also set forth the estimated net savings attributable to the recommendation and will further provide that the Contractor be paid 50 percent of said savings. The cost to the project in evaluating the recommendation will be considered in determining the estimated net savings. The Contractor's share of the savings shall constitute full compensation for the Value Engineering Incentive.

Approval of the recommendation and performance of the work thereof shall not change the contract completion date unless specifically provided for in the supplemental agreement implementing the work.

The Contractor may restrict the State's and County's right to use or disclose the information submitted with a recommendation. Such restriction must be in writing and submitted with the recommendation. If the recommendation is accepted, this restriction shall be void and the State and County may use, duplicate or disclose any data necessary to utilize such recommendation. The executed supplemental agreement implementing the recommendation will become public information in the files of the State and County.

This incentive provision applies only to contracts awarded pursuant to competitive bidding.

**S-105.01--Authority of the Engineer.** The Engineer, acting as the duly authorized representative of the Board and subject to the rules and regulations and approval of the State Aid Engineer, shall decide all questions which may arise as to the quality and acceptability of materials furnished and work performed and as to the rate of progress of the work; all questions which may arise as to the interpretation of the plans and specifications; and all questions as to the fulfillment of the contract on the part of the Contractor.

The Engineer has the authority to suspend the work wholly or in part and to withhold payments due to failure of the Contractor to correct conditions unsafe for workmen or the general public; for failure to carry out provisions of the contract; for failure to carry out orders; for periods he may deem necessary due to unsuitable weather conditions; for any conditions considered unsuitable for the prosecution of the work; or for any other condition or reason deemed to be in the public interest.

The Engineer has executive authority to enforce and make effective all decisions and orders relating to the contract, but is not authorized to change the obligations of the Board to the Contractor or waive any rights of the Board under the contract.

**S-105.02--Plans and Working Drawings.** The County Engineer will furnish the Contractor two bound copies of the proposal and contract documents and three half-scale copies of the plans without charge. The Contractor shall have one copy of the proposal and contract documents and one half-scale copy of the plans available on the project at all times during work activity on the project.

Plans will show details of all structures, lines, grades, typical cross sections of the roadway, and a summary of items appearing in the proposal.

Any authorized alterations affecting the requirements and information given on the approved plans, or changes made on any plan or drawing upon which the contract was awarded, shall be made only with the State Aid Engineer's written approval.

The plans will be supplemented by working drawings necessary to adequately control the work. Working drawings for structures are not included in the plans furnished by the Board. They shall be furnished by the Contractor and shall consist of detailed plans necessary to adequately control the work. They shall include stress sheets, shop drawings, erection plans, false-work plans, cofferdam plans, bending diagrams for reinforcement, and other supplementary plans and similar data as required. All working drawings shall be submitted to the Engineer for approval, as required, but this approval will not relieve the Contractor of any of his responsibility under the contract.

If required, the original tracings of working plans or drawings shall be furnished the Engineer.

The contract price bid shall include the cost of furnishing all working drawings. If, however, design details of the plans are changed after the Contractor has submitted the required working drawings, the Engineer may order the Contractor to furnish revised or new working drawings, based on changed plan details, as Extra Work.

**S-105.03--Conformity with Plans and Specifications.** All work performed and all materials furnished shall be in reasonably close conformity with the line, grades, cross-sections, dimensions, material requirements, and other construction requirements shown on the plans or indicated in the specifications.

Contract specification values are target values to be strived for and from which tolerances are allowed. It is the intent of the specifications that the materials and workmanship shall be uniform in character and shall conform as nearly as realistically possible to the prescribed target value or to the middle portion of the tolerance range. The purpose of the tolerance range is to accommodate occasional minor variations from the median zone that are unavoidable for practical reasons. When either a maximum and minimum value or both are specified, the production and processing of the material and the performance of the work shall be so controlled that the material or work will not be predominately of borderline quality or dimension.

In the event the Engineer finds the materials, or the finished product in which the materials are used, not to be within reasonably close conformity with the plans and specifications but that reasonably acceptable work has been produced, he will then make a determination if the work will be accepted and remain in place. In this event the Engineer will make an appropriate adjustment in the contract price for the work or materials as provided in the specifications. In the event no provision for adjustment in contract price is included in the contract, the Engineer will document the basis of acceptance by contract modification which will provide for an appropriate adjustment in contract price for the work or materials as he deems necessary to conform to his determination. His determination will be: (1) based on the Office of State Aid Road Construction Standard Operating Procedures for adjustment in contract price in effect at the time of such contract modification or (2) in the event no standard criteria for adjustment of the contract price for the items involved has been issued, based on engineering judgment.

In the event the Engineer finds the materials or the finished product in which the materials are used or the work performed are not in reasonably close conformity with the plans and specifications and have resulted in an inferior or unsatisfactory product, the work or materials shall be removed and replaced or otherwise corrected by and at the expense of the Contractor.



**S-105.04--Coordination of Plans, Specifications, Supplemental Specifications, Special Provisions and Notice(s) to Bidders.** These specifications, supplemental specifications, plans, special provisions, notices to bidders, and all other supplemental documents are essential parts of the contract, and a requirement occurring in one is as binding as though occurring in all. They are intended to be complementary and to describe and provide for a complete work. In case of discrepancy, calculated dimensions will govern over scaled dimensions; the word "day" appearing anywhere in the contract shall mean work days unless the context is determined to indicate otherwise; and parts of the contract will prevail in the following order:

1. Notices to Bidders
2. Special Provisions
3. Plans
4. Supplemental Specifications
5. Standard Specifications

In case of conflict between a plan quantity and the advertisement and/or proposal, the plan quantity shall prevail.

The Contractor shall not take advantage of any apparent error or omission in the plans or specifications. In the event the Contractor discovers an error or omission, he shall immediately notify the Engineer. The Engineer will then make corrections and interpretations deemed necessary for fulfilling the intent of the plans and specifications. A reference in any contract document to controlling requirements in another portion of the contract documents shall be understood to apply equally to any revision or amendment thereof included in the contract. In the event the plans or proposal inadvertently contain references to an Edition of the Mississippi Standard Specifications for State Aid Road and Bridge Construction other than that listed in the proposal Table of Contents, it is to be understood that such references shall mean the comparable provisions of the Edition so listed.

**S-105.05--Cooperation by Contractor.** The Contractor shall keep available on the work at all times during working hours one set of approved plans, standard specifications, and proposal assemblies.

The Contractor shall give the work the attention necessary to expedite its progress, and shall cooperate with the Engineer, his inspectors, and other contractors in every way possible.

The Contractor shall have on the work and available to the work at all times, as his agent, a competent resident superintendent capable of reading and thoroughly understanding the plans and specifications and thoroughly experienced in the type of work being performed. The superintendent shall receive instructions from the Engineer or his authorized representative. Upon issuance of the Notice to Proceed, the Contractor or his duly appointed agent authorized to bind the Contractor shall file with the Board, with copies to the State Aid Engineer, and the County Engineer, the name and address of the superintendent who will supervise the work. The Board shall be immediately notified in writing with copies to those stated, if any changes are made in the Contractor's superintendent or his address.

The superintendent shall have full authority to execute orders or directives of the Engineer without delay, and to promptly supply materials, equipment, labor, and incidentals as may be required. Such superintendence shall be furnished irrespective of the amount of work sublet. The superintendent shall advise the Engineer of an intended absence from the work and designate a person to be in charge of the work during such absence.

**S-105.06--Cooperation with Utilities.** The Engineer will notify all utility companies, all pipe line owners or other known parties affected and endeavor to have a plan and agreement for all necessary adjustments of utilities, pipe lines or other appurtenances which are within or adjacent to the limits of construction before bids are received. Such utility plans or agreements will be made available for inspection by the Contractor in the Chancery Clerk's Office. The County will also endeavor to have all necessary adjustments made as soon as practicable.

All relocation or adjustment of utility appurtenances within the limits of the proposed construction will be performed by others unless otherwise specified.

The Engineer will notify all utility companies, at the time the work order is issued to the Contractor, that work is beginning on the project.

All known utilities within the project are shown on the plans. It is understood and agreed that the Contractor has considered in his bid all of the utility appurtenances in their present or relocated positions and that no additional compensation will be allowed for delays, inconvenience, or damage sustained by him due to interference from the said utility appurtenances or the operation of moving them. In the event the Engineer determines that the removing, relocation, or adjusting of utility appurtenances, or failure to do so, by others is causing delays in major phases of construction which normally should be in progress at the time, such delays will be considered delays by the State in the determination of extension of contract time.

**S-105.06.1--High Voltage Overhead Lines.** The Contractor shall not perform any function or activity upon any land, building, highway or other premises if at any time during the performance of that function or activity the person performing the function or activity could be reasonably expected to move or be placed within 10 feet of any high voltage overhead line or if any equipment or part of any tool or material used by the person could be reasonably expected to move or be placed within 10 feet of any high voltage overhead line during the performance of any function or activity.

The Contractor shall comply with the State of Mississippi law concerning work within the proximity of overhead power lines.

No person shall, individually or through an agent or employee, operate or bring any mechanical equipment or hoisting equipment or any other equipment or part of any tools or material within 10 feet of any high voltage overhead line.

If any person desires to carry on any function, activity, work or operation in closer proximity to any high voltage overhead line than permitted by this chapter, the person responsible for performing the work shall promptly notify the electric utility operating the high voltage overhead line, in writing, on a form to be provided by such electric utility, and shall not perform the work until mutually satisfactory arrangements have been made between such electric utility and the person or business entity responsible for performing the work.

The required 10 foot clearance shall not be provided by movement of the high voltage overhead line through strain impressed, by attachments, or otherwise.

The person responsible for performing the work in the vicinity of the high voltage overhead lines shall at no cost to the County or State, receive a written cost estimate from the utility for providing the necessary safety arrangements.

"High voltage" means a voltage in excess of six hundred (600) volts between conductors or from any conductor to ground.

"Overhead lines" mean all bare or insulated electrical conductors installed above the ground.

"Warning sign" means a weather-resistant sign of not less than 7 inches by 10 inches reading as follows: "DANGER-UNLAWFUL TO OPERATE THIS EQUIPMENT NEARER THAN 10 FEET TO HIGH VOLTAGE OVERHEAD LINES."

Any person who knowingly violates this chapter may be subject to a civil penalty in an amount not to exceed Five Thousand Dollars (\$5,000.00) to be imposed by a court of competent jurisdiction against said person.

The Form entitled, "NOTICE OF WORK TO BE PERFORMED IN PROXIMITY OF HIGH VOLTAGE POWER LINE" is included in the contract documents. The top portion only of the form shall be completed, signed and returned by the Contractor upon execution of the contract. The County Engineer will transmit a copy of the signed form to each of the electric utility companies that may be involved with providing protective services.

It is not expected that the Contractor will suffer any cost from the utility company providing necessary safety arrangements when a high voltage overhead line is located on right-of-way. When an electric utility company claims otherwise, the Contractor shall notify the County Engineer so the County may take appropriate action.

**S-105.07--Cooperation Between Contractors.** The Board and the State Aid Engineer reserves the right at any time to award contracts for and perform other or additional work on or near the work covered by the contract. Each Contractor will be expected to cooperate with the other Contractor(s) and with the Board in every reasonable manner.

The Board and the State Aid Engineer will make a determination as to the practicability of prosecuting an existing contract in an area before an additional award is made for work in the same area. Insofar as is practicable, the Board will give notice of the intent to award subsequent contracts in the same area. Failure to do so, however, shall not prejudice the rights of the Board to award additional contracts and shall not constitute grounds for claims against the Board.

When separate contracts are let for work, any part or all of which is within the same limits, each Contractor shall conduct his work so as to cause the least interference with or hindrance of the progress and completion of work being performed by other Contractor(s).

Each Contractor shall arrange his work and shall place and dispose of the materials and equipment being used so as not to interfere with the operations of the other Contractor within limits of the same work. He shall join his work with that of others in an acceptable manner and shall perform it in the sequence called for by the plans and contract documents or as directed.

Each Contractor involved shall assume all liability, financial and otherwise, in connection with his contract and shall protect and save harmless the County and State from all damages or claims that may arise because of inconvenience, delay, or loss experienced by him because of the presence and operations of the other Contractor(s) working within the same contract limits.

If railroad work is to be performed under separate contract let by the Board with the approval of the State Aid Engineer, all the provisions of this subsection are applicable. If the railroad work is to be performed by the railroad or its contractor, all the provisions of this subsection are applicable except that a schedule of operations will not be required of the railroad.

**S-105.08--Construction Stakes, Lines and Grades.** The Engineer will set construction stakes establishing lines, slopes, and profile grade in road work, and all necessary lines and grades to control the work on bridge work, culvert work, protective and accessory structures, and appurtenances as he may deem necessary, and will furnish the Contractor with all necessary information relating to lines, slopes, and grades. The Contractor, however, will be required to check all the controlling dimensions and clearances measured from such stakes and thereafter become responsible for alignment, elevation, and dimensions of all parts of the work and their mutual agreement.

The Contractor shall be held responsible for the preservation of all stakes and marks, and if any of the construction stakes or marks have been carelessly or willfully destroyed or disturbed by the Contractor, the cost of replacing them will be the Contractor's responsibility and costs will be deducted from the current progress estimate if agreed to by the State Aid Engineer and the Board of Supervisors.

**S-105.09--Authority and Duties of the County Engineer.** As the representative of the Board and the State Aid Engineer, the County Engineer has immediate charge of the engineering details of the contract. He is responsible for the administration and satisfactory completion of the work in accordance with the contract, and he is delegated authority commensurate with these responsibilities.

**S-105.10--Duties of the Inspector.** Inspectors employed by the Board or Engineer will be authorized to inspect all work done and materials furnished. The inspection may extend to all parts of the work and to the preparation, fabrication, or manufacture of the materials to be used. The inspector will not be authorized to alter or waive the provisions of the contract or to issue instructions contrary to the plans and specifications, or to act as foreman for the Contractor.

**S-105.11--Inspection of Work.** All materials and each part or detail of the work shall be subject to inspection by the Engineer. The Engineer shall be allowed access to all parts of the work and shall be furnished with such information and assistance by the Contractor as is required to make a complete and detailed inspection. The Contractor shall be required to give the Engineer notice before beginning or doing any work or continuing any work after any delay in construction.

If the Engineer requests it at any time before acceptance of the work, the Contractor shall remove or uncover such portions of the finished work as may be directed. After examination, the Contractor shall restore said portions of the work to the standards required by the specifications. Should the work thus exposed or examined prove acceptable, the uncovering, or removing, and the replacing of the covering or making good of the parts removed will be paid for as Extra Work; but should the work so exposed or examined prove unacceptable, the uncovering, or removing, and the replacing of the covering or making good of the parts removed will be at the Contractor's expense.

Work done or materials used without supervision or inspection by the Engineer or his authorized representative may be ordered removed and replaced. This work will be inspected and accepted or rejected in accordance with the preceding paragraph except that the uncovering or removing shall not be paid for as extra work.

When any unit of government or political subdivision or railroad corporation or other public service is to pay a portion of the cost of the work covered by this contract, its respective representatives shall have the right to inspect the work. Such inspection shall in no way make the unit of government or political subdivision or railroad corporation or other public service a party to this contract, and shall in no way interfere with the rights of either party hereunder.

**S-105.12--Removal of Unacceptable and Unauthorized Work.** All work which does not conform to the requirements of the contract will be considered as unacceptable work, unless otherwise determined acceptable under the provisions of S-105.03.

Unacceptable work, whether the result of poor workmanship, defective materials, damage through carelessness, or any other cause, found to exist prior to the final acceptance of the work, shall be removed immediately and replaced in an acceptable manner.

No work shall be done without lines and grades having been given or approved by the Engineer. Work done contrary to the instructions of the Engineer, work done beyond the lines shown on the plans, or as given, except as herein specified, or any extra work done without authority, will be considered as unauthorized and will not be paid for under the provisions of the contract.

Upon failure on the part of the Contractor to comply promptly with an order of the Engineer made under the provisions of this subsection, the Engineer will have authority to cause unacceptable work to be remedied or removed and replaced and unauthorized work to be removed and to deduct the costs from monies due or to become due the Contractor.

**S-105.13--Load and Speed Restrictions.** The Contractor shall comply with all legal load restrictions in the hauling of materials on public roads beyond the limits of the project. A special permit will not relieve the Contractor of liability for damages which may result from the moving of material or equipment. The Contractor will be responsible for repairs, at his own expense, for damages to public roads off the project which were caused by him through violation of all legal load restrictions.

The operation of equipment within the project limits of such weight or so loaded as to cause damage to structures or the roadway or to any other type of construction will not be permitted. Hauling of materials over the base course or pavement courses under construction shall be limited to the maximum legal loads, both gross and axle loads, allowed on Mississippi county highways. No loads will be permitted on a concrete base, or structure before the expiration of the curing period. In no case shall legal load limits be exceeded after processing the surface of the design soil for placement of subsequent subbase, base, and pavement courses unless permitted in writing. The Contractor shall be responsible for all damages caused by his hauling equipment.

When required by the Board and concurred in by the State Aid Engineer, the Contractor shall furnish approved platform scales or a sufficient number of approved portable scales, together with essentials for calibrating, to check load weights on the project, and shall provide all labor, tools, and equipment necessary to weigh as many loaded vehicles as will assure the Engineer of the Contractor's compliance with legal load limits or those directed or authorized. The cost of scales, when necessary, will not be a pay item and all cost will be borne by the Contractor.

The Contractor shall be responsible for maintenance of safe and reasonable speeds of vehicles assigned to the project. Further, reduced speeds may be ordered in writing by the Engineer when in his opinion lower speeds are essential to the public safety or to the quality of the completed work.

**S-105.14--Maintenance During Construction.** The Contractor shall maintain all the work during construction and until the work is finally accepted. The Board may, however, with approval of the State Aid Engineer, release the Contractor from maintenance of part or all of the project before final acceptance and the maintenance of that part of the project described in the joint release statement of the Board and State Aid Engineer shall be the full responsibility of the Board.

Maintenance shall constitute continuous and effective work prosecuted day by day, with adequate equipment and forces to the end that the roadway, or structures are kept in satisfactory condition at all times.

In the event that the Contractor's work is ordered shut down for failure to comply with the provisions of the contract the Contractor shall maintain the roadway and structures, as provided herein, and provide ingress and egress for local residents during the period of suspended work or until the contract has been declared in default.

All cost of maintenance work during construction and before the work is finally accepted shall be included in the unit price bid on the various pay items and the Contractor will not be paid an additional amount for such work.

**S-105.15--Failure to Maintain Roadway or Structures.** If the Contractor, at any time, fails to comply with the provisions of S-105.14, the Engineer will immediately notify the Contractor of such non-compliance. If the Contractor fails to remedy unsatisfactory maintenance within twenty-four(24) hours after receipt of such notice, the Engineer, subject to the approval of the State Aid Engineer, may immediately proceed to maintain the project with such forces as he deems necessary.

The entire cost of maintenance, as provided herein, requiring forces, equipment, materials, and incidentals other than those provided by the Contractor will be deducted from monies due or to become due the Contractor under his contract.

**S-105.16--Acceptance.** When, in the opinion of the Engineer, the Contractor has satisfactorily completed all work prescribed in his contract, he will so notify the State Aid Engineer on a form provided by the State Aid Engineer, requesting that a joint final inspection be made. If on such joint final inspection it is agreed by the Engineer and the State Aid Engineer's representative that the work has been completed in accordance with the terms of the contract, then the Board and the State Aid Engineer will issue a final acceptance notice to the Contractor officially accepting the work and thereby relieving the Contractor of further construction and maintenance responsibility.

The acceptance of projects financed, in whole or in part, with Federal funds will require the approval of the Director and the Federal Highway Administration, except FHWA acceptance is not required on projects considered exempt by FHWA.



**S-105.17--Claims for Adjustments and Disputes.** It is in the public interest that the Board and the State Aid Engineer have early or prior knowledge of an existing or impending claim of any nature by the Contractor. The Board and the State Aid Engineer may then consider modifying the details of the work or other actions which might result in mitigation or elimination of the effect of the act or conditions objected to by the Contractor. The Board and the State Aid Engineer may then institute appropriate procedures, as required, to keep strict account of actual costs and to verify at the time, facts upon which a claim for contract adjustment is made. Therefore, if in any case the Contractor deems that additional compensation is due for work or materials not clearly covered in the contract or not ordered by the Engineer as Extra Work, or if the Contractor deems that adjustment in the contract time should be made because of any of the reasons provided for in the contract as a basis for an extension of time, the Contractor shall notify the Engineer in writing of an intention to make such claim for additional compensation before beginning the work on which the Contractor bases the claim or for such extension of time as soon as the facts first become known on which the Contractor bases the claim for adjustment. If such written notification is not given by the Contractor in accordance with these specifications, the Contractor hereby agrees that failure to provide written notice has denied the Board and the State Aid Engineer the prerogative of verifying additional time, materials, equipment, labor and making adjustment in the work which might remove or mitigate the conditions for which a claim might be made, and the Contractor further agrees that such failure on the Contractor's part shall be a conclusive waiver of any claim, or part thereof.

Mere oral notice or statement will not be sufficient, nor will an unnecessarily delayed notice or statement after the event.

Any such notice shall be in writing and shall describe any act of omission or commission by the Board and the State Aid Engineer or their agents that allegedly caused or contributed to the condition for which a claim may be made and the nature of the claimed damage. The Contractor shall deliver or mail the notice to the Engineer.

Upon receipt of the notice, the Engineer will acknowledge receipt in writing to the Contractor with a copy of the notice and acknowledgment to the Office of State Aid Road Construction.

The Engineer will evaluate the Contractor's claim and forward his/her recommendations to the Office of State Aid Road Construction.

The District Engineer for the Office of State Aid Road Construction will verify the Contractor's claim and request that the State Aid Engineer take the necessary steps to review the legitimacy of the Contractor's documentation of the claim.

Even when the State Aid Engineer determines that the Contractor's documentation relative to the time, materials, equipment and labor are legitimate, the Engineer and the Office of State Aid Road Construction will continue to monitor the Contractor's charges until the Contractor's services are complete.

Such notice by the Contractor and the fact that the Engineer has kept account of the costs and the State Aid Engineer has verified the legitimacy of the Contractor's documentation and other facts as aforesaid shall not in any way be construed as substantiating the validity of a claim.

In presenting a claim, the Contractor shall clearly and specifically state:

- (a) The contract subsection number(s) under which each part of the claim is made.
- (b) The event(s) or condition(s) covered in each such subsection(s) and made the basis for each part of the

A claim for additional compensation shall include supporting auditable cost figures from entries made in the original records entered at the time of the work. The Contractor will be required to provide all records that the Office of State Aid Road Construction deems necessary for the performance of an audit in accordance with the United States General Accounting Office's Governmental Auditing Standards, the Institute of Internal auditor's Professional Practice Standards, and the American Institute of Certified Public Accountant's Standards.

All claims made shall be sent to the Engineer for review and processing.

If a claim is so vague that the Engineer cannot reasonably and expeditiously determine the specific contractual provisions relied on by the Contractor as the basis of each part of the claim, or if the Office of State Aid Road Construction cannot reasonably and expeditiously determine that the costs related to the claim are related specifically to the referenced project and are not related to any other project(s) that the Contractor is constructing or has constructed, it will be denied by the Engineer or returned without action.

Any part of a claim based on after-the-fact general statements of costs such as "Normal cost of such work", computed as a percentage of ....., etc." or other such indefinite statements will be denied or returned to the Contractor without action.

The Engineer may request supplemental data in writing, or return the claim to the Contractor for resubmission in accordance with these specifications.

A claim, as approved by the Board and the State Aid Engineer, will be paid in accordance with the provision of S-104.02 and S-104.03 and adjustments in contract time will be made in accordance with the provision of S-108.06. When a claim is denied or returned without action, the notice will state the reasons therefor.

**S-105.18--Automatically Controlled Equipment.** Unless otherwise prohibited in other sections of the specifications or other contract documents, automatically controlled equipment that malfunctions may be operated manually or by other approved methods for a period of time approved by the Engineer so as to prevent loss or damage to the work already produced, manufactured, or processed at the time of the breakdown or malfunction. The resulting work must meet the requirements of the contract.

**S-106.01--Source of Supply and Quality Requirements.**

**S-106.01.1--General.** The materials used in the work shall meet all quality requirements of the contract. At the option of the Engineer, materials may be tested at the source of supply to determine conformance with the specifications, in which case the Contractor shall notify the Engineer of his proposed source of material well in advance of the time of proposed delivery to the work in order to expedite the inspection and testing. If it is found after trial that sources of supply for previously approved materials do not produce uniform and satisfactory products, or if the product from any source proves unacceptable at any time, the Contractor shall furnish materials from other approved sources.

**S-106.01.2--Warranties, Guaranties, Instruction Sheets and Parts Lists.** For manufactured articles, units, components, or materials for use as or incorporated in any mechanical or electrical facility required under the contract, the manufacturer's warranties, guaranties, instruction sheets, and parts lists, normally available to the purchaser, shall be delivered to the Engineer by the Contractor before final acceptance of the work.

**S-106.02--Local Materials Sources.**

**S-106.02.1--Local Materials Sources General.** Possible sources of local material may be designated on the plans or described in the Special Provisions. The quality of material in such deposits will be acceptable in general, but the Contractor shall determine for himself the amount of equipment and work required to produce uniform, acceptable material. It shall be understood that it is not feasible to ascertain from samples the specific limits of acceptable material from the entire deposit and variations shall be considered as usual and are to be expected. The Engineer may order procurement of material from any portion of the deposit and may reject other portions of the deposit as unacceptable.

The Contractor shall construct and maintain all necessary haul roads to facilitate hauling of material from any and all pits or sources of material and shall bear all costs of clearing and grubbing, furnishing all material, constructing, maintaining (including sprinkling as required) and all other costs related to haul roads.

All pits and quarry sites shall be subject to the approval of the Engineer prior to opening.

Unless otherwise permitted by the Engineer in writing, borrow pits, gravel pits, other pits and quarry sites, exclusive of commercially operated sources determined not to have been opened primarily to provide material for work under the contract, shall be so located as not to be visible from a public highway. In the event any pits or quarries are permitted to be located so that they are visible from a public highway, site grading, roadside development, or other items will be required as necessary to prevent an unsightly appearance of the disturbed area.

The Contractor will be responsible for all permits and licenses required to operate a borrow pit and will comply with requirements of S-107.23.

The Contractor shall so schedule and conduct all clearing and grubbing operations, stripping, opening up of the source, and all mining and hauling operations, and shall so finish and protect the surface of the disturbed area(s) as to prevent, where practicable, or otherwise minimize siltation or pollution of ditches, streams, lakes, reservoirs and adjacent property with sediment, fuels, oils, or other objectionable material occasioned by, or as a result of, his operations. Where site grading, roadside development or other items of work are required in the contract, the performance of such work shall be in the particular manner and sequence related to pit operations as deemed necessary to promote the stability of the surface of the disturbed area of the pit and to promote the maximum possible permanent vegetation establishment at the earliest possible time.

Unless the excavations, pits or quarries are determined to be appropriate to serve as lakes or ponds for recreational or other purposes, the area shall be finished, where practicable, so that the water will not collect or pond therein. Unless otherwise specified or permitted in writing, the areas or surfaces of waste overburden or stripping shall be finished, neatly dressed and terraced or otherwise left in a satisfactory condition to prevent, where practicable, or minimize siltation and pollution of ditches, streams, lakes, reservoirs and adjacent property. All excavation pits or quarries shall be given a final cleaning up in accordance with the provisions of S-104.07.

**S-106.02.2--Contractor Furnished Sources.** The Contractor shall provide sources of materials meeting the requirements of the contract and shall bear all costs involved, including pit explorations, necessary permits, licenses and environmental and other clearances before opening a source of materials. Testing of all materials shall be done by MDOT or a State Aid approved testing laboratory.

The Contractor shall certify that the material, from his sources, has been tested and will meet specifications. The Engineer will be responsible for job control sampling and testing during production of the material.

**S-106.03--Samples, Tests, and Cited Specifications.** All materials used in the work shall conform to the general requirements of S-700, Materials and Tests, and, in addition, shall conform to the specific requirements of the various Subsections of S-700 cited for the various items of work. Cited Specifications of AASHTO, ASTM or Federal Specifications for materials or test methods shall be understood to mean approved pre-published or published "Standards" of ASTM, AASHTO, Federal Specifications, Interim Specifications of AASHTO (denoted by the suffix "I"), Tentative Specifications of ASTM (denoted by the suffix "T"); or Federal Specifications (denoted by a numbered amendment) current on the date of advertisement for bids. All materials will be inspected and tested for acceptance in accordance with S-700.03 unless otherwise provided. The work shall be considered incomplete until acceptance of all materials used in the work. Any work performed prior to approval of materials will be the sole responsibility of the Contractor.

It is understood that the County reserves the right to retest all materials even though they have been tested and approved before incorporation in the project and to reject all materials which, when retested, do not meet the requirements of the contract.

Prior inspection, test, and approval of material used as a component of other items of work for which there is a pay item in the contract shall in no way imply acceptance and payment or reimbursement to the Contractor for such previously approved material if the work in which the materials are incorporated fails to meet the requirements of the contract.

Copies of all test reports will be furnished to the Contractor's representative at his request.

**S-106.04--Certification of Compliance.** The Engineer may permit use, prior to sampling and testing by the County, certain materials or assemblies accompanied by acceptable certificates of compliance stating that such materials or assemblies fully comply with the requirements of the contract. Each lot of such materials or assemblies delivered to the work must be accompanied by an approved certificate of compliance in which the lot is clearly identified.

Certificates of compliance shall meet the following requirements.

I. Certifications:

- (a) Show the letterhead of the manufacturer, producer, supplier, or fabricator, as applicable.
- (b) Include the project number.
- (c) Contain an itemized list of materials covered by the certification.

- (d) Contain a material conformance statement.-- This statement should certify that the materials listed conform to the specific specification requirements. (Example: I/we hereby certify the materials listed below conform to the requirements of the Mississippi Standard Specifications for Office of State Aid Road Construction S-714.12.)
- (e) Bear the signature of a responsible company official.
- (f) Certification for all iron, steel and steel wire products must also include a certified statement by the manufacturer that all of the manufacturing processes, excluding those for pig iron and processed, pelletized, and reduced iron ore used in the manufacture of said steel and/or iron products, have occurred domestically.

## II. Certified Test Reports:

- (a) Show the letterhead of the manufacturer, producer, supplier, fabricator, or laboratory, as applicable.
- (b) Include the name and description of material tested, number, heat number, etc., as applicable.
- (c) Show the test results obtained for each test required, and state that the material was run according to the test method specified in the contract.
- (d) Be signed by a supervisor of the laboratory performing the tests.
- (e) Test reports for all iron, steel and steel wire products must also include a certified statement by the manufacturer that all of the manufacturing processes, excluding those for pig iron and processed, pelletized, and reduced iron ore used in the manufacture of said steel and/or iron products, have occurred domestically.

Certifications or Certified Test Reports will not be accepted unless they comply with the foregoing. Conformance requirements for the certification of asphalt and cement are set out separately in Mississippi Department of Transportation S.O.P. TMD-22-0100-000 and Mississippi Department of Transportation S.O.P. TMD-21-0100-000, respectively.

Materials and assemblies used on the basis of Certificates of Compliance may be sampled and tested at any time and if found not to be in conformity with contract requirements will be subject to rejection whether in place or not.

Unless otherwise requested by MDOT, the original and three copies of all Certificates of Compliance shall be furnished to the County Engineer. Payment for the work will not be made until proper certification has been received unless specifically provided for elsewhere in the contract.

**S-106.05--Plant Inspection.** The Contractor shall provide access at any facility used in the production of materials, for authorized State, County and FHWA personnel to inspect and test materials supplied for the project.

In the event such plant inspection is undertaken the following conditions shall be met:

- (a) The Engineer shall have the cooperation and assistance of the Contractor and the producer with whom he has contracted for materials.
- (b) The Engineer shall have full entry at all times to parts of the plant as may concern the manufacture or production of the materials being furnished.
- (c) When specified, the Contractor shall provide an approved laboratory unit conforming to the applicable requirements of MDOT Specifications Section 621.
- (d) The Board and State Aid Engineer reserves the right to retest all materials which have been tested and accepted at the source of supply after the materials have been delivered and to reject all materials which do not meet the requirements of these specifications.

**S-106.06--Field Laboratory.** When specified, the Contractor shall provide for the exclusive use by the Engineer one or more approved field laboratory buildings or portable trailers in which to house and use the equipment necessary to carry on the required tests.

It shall be understood that conditions and construction operations vary from one project to another, and that more or less than the estimated number of laboratory units may be required. The Engineer shall be the sole judge as to the number of laboratory units required, estimated plan quantities of units notwithstanding.

Each unit required shall be in accordance with the requirements and provisions of MDOT Standard Specifications Section 621.

**S-106.07--Foreign Materials.** Foreign materials are defined as being any material or manufactured product whose manufacturing process takes place outside the United States.



**S-106.08--Storage of Materials.** Materials shall be so stored as to assure the preservation of their quality and fitness for the work. Stored materials, even though approved before storage, may again be inspected or tested prior to their use in the work. Stored materials shall be located so as to facilitate their prompt inspection. Approved portions of the right-of-way may be used for storage purposes and for the placing of the Contractor's plant and equipment, but any additional space required therefor must be provided by the Contractor at his expense.

Private property shall not be used for storage purposes without written permission of the owner or lessee, and duplicate copies of such written permission shall be furnished the Engineer. All storage sites shall be restored to their original conditions by the Contractor at his expense. This shall not apply to the stripping and storing of topsoil or to other materials salvaged from the work for use by the County on other work.

**S-106.09--Handling Materials.** All materials shall be handled in such manner as to preserve their quality and fitness for the work. Materials shall be transported from the storage or other site to the work in tight vehicles so constructed as to prevent loss or segregation of materials after loading and measuring in order that there may be no inconsistencies in the quantities of materials intended for incorporation in the work as loaded, and the quantities as actually received at the place of use.

**S-106.10--Unacceptable Materials.** All materials not conforming to the requirements of the specifications at the time they are used shall be considered as unacceptable and all such materials will be rejected and shall be removed immediately from the site of the work unless otherwise instructed by the Engineer. No rejected material, the defects of which have been corrected, shall be used until approval has been given in writing by the Engineer.

**S-106.11--Convict Produced Materials:**

Materials produced after July 1, 1991, by convict labor may only be incorporated in a Federal Aid highway construction project if such materials have been:

- (1) Produced by convicts who are on parole, supervised release, or probation from a prison or
- (2) Produced in a qualified prison facility and the cumulative annual production amount of such materials for use in Federal Aid highway construction does not exceed the amount of such materials produced in such facility for use in Federal Aid highway construction during the 12-month period ending July 1, 1987.

## **SECTION S-107 - LEGAL RELATIONS AND RESPONSIBILITY TO PUBLIC**

**S-107.01--Laws to Be Observed.** The Contractor shall keep fully informed of all Federal and State laws, all local laws, ordinances, and regulations and all orders and decrees of bodies or tribunals having any jurisdiction or authority, which in any manner affect those engaged or employed on the work, or which in any way affect the conduct of the work. He shall at all times observe and comply with all such laws, ordinances, regulations, orders, and decrees, and shall protect and indemnify the State and County and its representatives against all claims or liability arising from or based on the violation of such laws, ordinances, regulations, orders, or decrees, whether by himself or his employees, subcontractors or their employees, or agents of either.

Open burning of combustible materials shall be in accordance with current rules and regulations of the Mississippi Department of Environmental Quality, Office of Pollution Control. The basic requirements contained herein for open burning to dispose of vegetation from clearing of right-of-way or construction site were published by the Mississippi Department of Environmental Quality in Regulation APC-S-1.

Open burning of land-clearing debris must not use starter or auxiliary fuels which cause excessive smoke (rubber tires, plastics, etc.); must not be performed if prohibited by local ordinances; must not cause a traffic hazard; must not take place where there is a High Fire Danger Alert declared by the Mississippi Forestry Commission or Emergency Air Pollution Episode Alert imposed by the Executive Director and must meet the following buffer zones.

- (1) Open burning without a forced-draft air system must not occur within 500 yards of an occupied dwelling.
- (2) Open burning utilizing a forced-draft air system on all fires to improve the combustion rate and reduce smoke may be done within 500 yards of but not within 50 yards of an occupied dwelling.
- (3) Burning must not occur within 500 yards of commercial airport property, private air fields, or marked off-runway aircraft approach corridors unless written approval to conduct burning is secured from the proper airport authority, owner or operator.

**S-107.02--Permits, Licenses, and Taxes.** Except as provided in S-107.09, and S-107.22, the Contractor shall procure all permits and licenses, pay all charges, fees, and taxes, and give all notices necessary and incidental to the due and lawful prosecution of the work.

The Contractor is advised that the “Mississippi Special Fuel Tax Law”, Section 27-55-501, et seq, Mississippi Code of 1972, Annotated, and it’s requirements and penalties apply to any contract for construction, reconstruction, maintenance or repairs, for contracts entered into with the State of Mississippi, any political subdivision of the State of Mississippi, or any Department, Agency, Institute of the State of Mississippi or any political subdivision thereof.

The Mississippi State Tax Commission will be notified of the name and address of Contractors that are awarded State Aid contracts. The Contractor will be subject to an audit during the life of this contract to make certain that all applicable fuel taxes are being paid promptly as outlined in Section 27-55-501, et seq., Mississippi Code of 1972, Annotated.

**S-107.03--Patented Devices, Materials, and Processes.** If the Contractor employs any design, device, material, or process covered by letters of patent or copyright, he shall provide for such use by suitable legal agreement with the patentee or owner. The Contractor shall not involve the Board and State Aid Engineer in the payment for royalties, either directly or indirectly, in violation of applicable State Laws to the contrary. Attention is invited to Section 65-1-61, Mississippi Code 1972, Annotated, regarding use of patented materials for paving. The Contractor and the Surety shall indemnify and save harmless the State, any affected third party, or political subdivision from any and all claims for infringement by reason of the use of any such patented design, device, material or process, or any trademark or copyright, and shall indemnify the County and State for any costs, expenses, and damages which it may be obligated to pay by reason of any infringement, at any time during the prosecution or after the completion of the work.

**S-107.04--Restoration of Surfaces Opened by Permit.** The right to construct or reconstruct any utility service in the highway or street or to grant permits for same, at any time, is expressly reserved by the Board or the proper authorities of the municipality, County, or State, as the case may be, in which the work is done. The Contractor will not be entitled to any damages from the Board for delays or damages due to utility service construction or reconstruction by a third party, except that when the Engineer determines a delay prevents the performance of the controlling phase(s) of work, contract time credit will be allowed.

Any individual, firm, or corporation wishing to make an opening in the highway must secure a permit from the Board. The Contractor shall allow parties bearing approved permits or agreements and only those parties, to make openings in the highway. When ordered by the Engineer, the Contractor shall make in an acceptable manner all necessary repairs due to such openings and such necessary work will be paid for as provided in these specifications, or as Extra Work, and will be subject to the same conditions as original work performed.

**S-107.05--Federal Aid Participation.** When the United States Government pays all or any portion of the cost of a project, the Federal laws and the rules and regulations made pursuant to such laws shall be observed by the Contractor, and the work shall be subject to the inspection of the appropriate Federal agency.

Such inspection shall in no way make the Federal Government a party to the contract and will in no way interfere with the rights of either party hereunder.

**S-107.06--Sanitary, Health and Safety Provisions.** The Contractor shall provide adequate sanitation facilities for the use of his employees, and shall maintain these facilities in a sanitary condition. The location of such accommodations shall be subject to the prior approval of the Engineer. He shall also provide adequate dust control on the project, or haul roads, and at other areas of operation.

Such accommodations shall be designed and operated to conform to the local and State health regulations. The Contractor shall not require any worker to work in surroundings or under conditions contrary to local, State, and Federal health and safety regulations. All such requirements and regulations shall be considered as binding upon the Contractor as if actually included in these specifications.

This shall be considered necessary work auxiliary to the accomplishment of the contract and no direct payment will be made therefor.

**S-107.07--Public Convenience and Safety.** The Contractor shall at all times so conduct his work as to assure the least possible obstruction to traffic. The safety and convenience of the general public and the residents along the road and the protection of persons and property shall be provided for by the Contractor as specified under S-104.04.

All work performed by the Contractor on grade separation structures, such as overpasses or underpasses of existing highways, roads, or streets, shall be done in a manner that will create the least practicable interference with the public use of the facility. The Contractor shall use all reasonable care and precaution to avoid accidents, damage, or unnecessary delay or interference with traffic, and, if necessary, in conjunction with this work the Contractor shall provide, without additional compensation, competent flaggers to insure the maximum public safety.

**S-107.08--Railroad-Highway Provisions.** If the contract requires that materials be hauled across the tracks of any railway or, if the Contractor elects to haul materials across the tracks of any railway, the Contractor shall make arrangements with the railway for any new crossings required or for the use of any existing crossings.

If a change is made by the Engineer in the sources of materials which results in the necessity for hauling across the tracks of the railway other than at the point anticipated in the contract the Engineer, acting for the Board, will make arrangements with the railway for any such new crossings required.

All work to be performed by the Contractor in the construction of grade separation structures or other work on the railroad right-of-way shall be done in a manner satisfactory to the Chief Engineer of the railroad company, or his authorized representative, and shall be performed at such times and in such manner as not to unnecessarily interfere with the movement of trains or traffic upon the track of the railroad company. The Contractor shall use all reasonable care and precaution in order to avoid accidents, damage, unnecessary delay, or interference with the railroad company's trains or other property and, if necessary in conjunction with his work the Contractor shall request the

railroad company to furnish a flagman and the expense for the use of such flagman shall be borne by the Contractor, unless otherwise specified.

The Board will have agreements with the railroad company(ies) for grade separation structure(s) to be constructed and these agreements will be available for the bidder's inspection in the office of the County Engineer and in the office of the State Aid Engineer.

In accordance with S-103.06 the Contractor will be required to carry such additional public liability and property damage insurance as may be stipulated in the contract documents.

#### **S-107.09--Construction Over Navigable Waters.**

Bridge or causeway construction, reconstruction or modification, over navigable waters of the U.S. that may interfere with their navigability shall be conducted in accordance with a U.S. Coast Guard approved bridge permit. Causeways and approach fills require Section 404 permits (see S-107.22).

The Board will obtain the Coast Guard bridge permit which will be available for bidders' inspection in the office of the County Engineer and at State Aid, or be included in the contract documents. Bidders are advised to closely examine the provisions of the permit relative to impacts on navigation and the environment. The Contractor shall comply with all provisions and conditions of the permit.

The permit covers only work shown on the plans. Should the Contractor propose temporary construction for his own convenience in the areas set out in the permits or changes in the project construction method that would result in changes to project impacts, he shall apply for and have in hand any additionally required permits or approvals before proceeding with construction.

**S-107.10--Barricades, Warning Signs and Flaggers.** The Contractor shall provide, erect, and maintain all necessary barricades, suitable and sufficient lights, danger signals, signs, and other traffic control devices; shall provide qualified flaggers where necessary to direct the traffic; and shall take all necessary precautions for the protection of the work and the safety of the public. Roads or parts of the work closed to through traffic shall be protected by effective barricades. Obstructions shall be illuminated during hours of darkness. Suitable warning signs shall be provided to properly control and direct traffic.

The Contractor shall erect warning signs in advance of all places on the project where operations may interfere with traffic, and at all intermediate points where the new work crosses or coincides with existing traveled roads. Such warning signs shall be constructed and erected in accordance with the provisions of the contract.

All barricades, warning signs, lights, temporary signals, other protective devices, flaggers and signaling devices shall conform with the minimum requirements contained in the MUTCD current at the time bids are received.

All traffic control devices on an existing highway, road or street are to be understood to be public property under the provisions of S-107.12.

On all sections of a project which are coincident with an existing highway, road, or street and are open to traffic, the Contractor shall be fully responsible for the protection, maintenance, and replacement of all existing signs, route markers, traffic control signals, and other traffic service features existing on the work from the beginning of contract time or beginning of work, whichever occurs earlier, until final acceptance of the work.

The Contractor shall restore or replace in kind, under the provisions of S-107.12, all devices damaged, destroyed, or lost.

On or about the effective date of the Notice to Proceed, the Engineer will make an inventory of all traffic control devices giving adequate description of each sign, post, message, signal, or other device as would be necessary to require replacement in kind.

A copy of the inventory, dated, identified, and signed is to be furnished the State Aid Engineer and the Contractor.

Prior to completion of the work, the Engineer will make an inventory of the traffic control devices, will make distribution of the inventory as indicated above for the earlier inventory, and will attach to the inventories a list and description in detail of the traffic control devices which have been damaged, destroyed, or lost and which must be replaced in kind by the Contractor.

Prior to performing work on the project, the Contractor shall make the necessary arrangements to prevent damage or loss of signs or other traffic control devices by providing adequate protection, or by removing those which cannot be left in their existing positions, protecting them from damage, and reinstalling them at locations approved by the Engineer so that they will provide maximum traffic service. As soon as work which conflicted with the original position of each device has been performed, the devices shall be immediately reinstalled at their original positions or modified positions as approved by the Engineer for reinstalling.

The Contractor shall maintain in position and effect only those signs that apply to conditions present. Signs that do not apply to existing conditions, or those which have served their purpose, shall be removed as indicated above or covered or turned so that they will not be readable by oncoming traffic, as approved by the Engineer. The Contractor shall not allow vegetation, construction materials, equipment, etc., to obscure an applicable traffic control device.

No change in posted regulatory speed signs may be made without the written authority of the Board. However, advisory speed plaques conforming to Section 6 F.48 of the MUTCD may be used in conjunction with the other standard warning signs, provided each posted advisory speed is appropriate and is localized to each individual hazard created by construction. All proposed changes in regulatory speeds shall be submitted through the Engineer, and is to be forwarded with his recommendations for further handling and possible action by the proper authorities.

Unless otherwise provided in the contract, no measurement for payment will be made for materials furnished or work performed under this subsection, it being understood that the cost of such materials and work is included in the contract unit price bid for Maintenance of Traffic or other items of work. Except in emergency situations, modifications to the temporary traffic control plan are to be treated as other design changes and shall be approved by the Engineer and the State Aid Engineer.

**S-107.11--Use of Explosives.** When the use of explosives is necessary for the prosecution of the work, the Contractor shall exercise utmost care not to endanger life or property, including new work. The Contractor shall be responsible for all damage resulting from the use of explosives.

The Contractor shall comply with all laws and ordinances as well as Title 29 Code of Federal Regulations Part 1926, Safety and Health Regulations for Construction (OSHA), with respect to the use, handling, loading, transportation and storage of explosives and blasting agents.

The Contractor shall notify each public utility company having structures in proximity to the site of the work, and known owners or operators of shortwave radio equipment in the area, of his intention to use explosives and such notice shall be given sufficiently in advance to enable those involved to take steps as they may deem necessary to protect their property.

**S-107.12--Protection and Restoration of Property and Landscape.** The Contractor shall be responsible for the preservation of public and private property and shall protect from disturbance or damage all land monuments, historical markers and property marks until the Engineer has witnessed or otherwise referenced their location, and shall not move them until directed.

The Contractor shall be responsible for all damage or injury to public or private property of any character, resulting from any act, omission, neglect, misconduct, inefficiency in his manner, or method of executing the work, or the non-execution thereof, or due to defective work or materials.

The Contractor shall take sufficient precaution to prevent pollution of streams, lakes, and reservoirs with any harmful materials including but not limited to fuels, oils, bitumens, calcium chloride, and poisons. He shall schedule and conduct his grading operations, production of materials from material pits or quarry sites (exclusive of commercially operated sources) construction of haul roads, hauling operations, and other operations so as to prevent or minimize the pollution of adjacent property, ditches, streams, lakes, and reservoirs with mineral or organic sediment. Unwarranted pollution of any nature will be considered to be injury or damage within the intent of this subsection, and such injury or damage shall be subject to the restoration requirements and provisions herein set forth.

When, or where, any damage or injury is done to public or private property by, or on account of any act, omission, neglect, or misconduct in the execution or nonexecution of the work by the Contractor, he shall restore, at his own expense, the property to a condition equal to that existing before the damage or injury was done, or he shall make good such damage or injury in an acceptable manner.

In case of failure on the part of the Contractor to restore or make good such damage or injury, the Engineer may, upon forty-eight hours written notice, proceed to repair, rebuild, or otherwise restore such property as may be deemed necessary, and the cost thereof shall be deducted from monies due or which may become due the Contractor. In the event no such monies are available the amount shall be charged against the Contractor's Surety. Nothing within this subsection shall be construed to relieve the Contractor from his responsibilities under the requirements of S-107.01.

**S-107.13--Forest Protection.** In carrying out work within or adjacent to State or National Forests, or other forest areas, the Contractor shall comply with all regulations of the State Fire Marshall, Forestry Commission, Forest Service, or other authority having jurisdiction, governing the protection of forests and the carrying out of work within forest areas. He shall observe all sanitary laws and regulations with respect to the performance of work in forest areas. He shall keep the areas in an orderly condition, dispose of all refuse, obtain permits for the construction and maintenance of all construction camps, stores, warehouses, residences, latrines, cesspools, septic tanks, and other structures in accordance with the requirements of the Forest Supervisor.

The Contractor shall take all reasonable precaution to prevent and suppress forest fires and shall require his employees and subcontractors, both independently and at the request of forest officials, to do all reasonably within their power to prevent and suppress and to assist in preventing and suppressing forest fires. He shall make every possible effort to notify a forest supervisor or other appropriate official at the earliest possible moment of the location and extent of any fire seen by them.



**S-107.14--Responsibility for Damage Claims.** The Contractor shall indemnify and save harmless the County and State, its officers, and employees from all suits, actions, or claims of any character brought because of any injuries or damage received or sustained by any person, persons, or property resulting from his operations; or on account of or in consequence of any neglect in safeguarding the work; or because of any claims or amounts recovered from any infringements of patent, trademark, or copyright; or from any claims or amounts arising or recovered under the "Workmen's Compensation Act," or any other law, ordinance, order, or decree; and so much of the money due the Contractor under and by virtue of his contract as may be considered necessary by the Board and State Aid Engineer for such purpose, may be retained for the use of the County and State; or, in case no money is due, his Surety may be held until such suit or suits, action or actions, claim or claims for injuries or damages as aforesaid shall have been settled and suitable evidence to that effect furnished to the Board and State Aid Engineer; except that money due the Contractor will not be withheld when the Contractor produces satisfactory evidence that he is adequately protected by public liability and property damage insurance.

**S-107.15--Third Party Beneficiary Clause.** It is not intended by any of the provisions of any part of the contract to create the public or any member thereof as a third party beneficiary hereunder, or to authorize any one not a party to this contract to maintain a suit for personal injuries or property damage pursuant to the terms or provisions of this contract. The duties, obligations, and responsibilities of the parties to this contract with respect to third parties, shall remain as imposed by law.

**S-107.16--Opening A Section of Road to Traffic.** Whenever an emergency or public necessity exists, the Board may declare the road or any section of the road open to public travel, although it may have been considered as closed for the duration of the contract. Such opening of the road to public travel shall not be construed as an acceptance of work, or any part thereof, or as a waiver of any of the provisions of these specifications and contract.

Should a structure or portion of the highway be opened to traffic, such opening will not be made until, in the opinion of the Engineer, the traffic will cause no injury to completed portions of the work. In the event of injury to completed portions of the work resulting from such opening and beyond the control of the Contractor, compensation for replacing such damaged work will be allowed as Extra Work as provided in S-104.03. The Contractor, however, shall make such provisions for the safety of the public as herein specified, or as the Engineer may direct and such opening shall not relieve the Contractor of his liability and responsibility during the period the work is so opened prior to final acceptance.

When specifically provided for in the special provisions, completed sections of the roadway may be accepted and the Contractor relieved of responsibility for such sections.

All damage which is the fault of the Contractor and not attributable to public traffic or slides, shall be repaired or replaced at the expense of the Contractor. The removal of slides and the performance of allied items incident thereto shall be performed by the Contractor under applicable items of the contract, or upon determination by the Engineer, as provided under S-104.02.

If the Contractor is dilatory in completing shoulders or other features of work, the Board, with the approval of the State Aid Engineer, may order all or a portion of the project open to traffic as set out herein; but in such event the Contractor shall not be relieved of his liability and responsibility during the period the work is so opened prior to release of maintenance. The Contractor shall conduct the remainder of his construction operations so as to cause the least obstruction to the safe and convenient movement of traffic.

**S-107.17--Contractor's Responsibility for Work.** Until final written acceptance of the project by the Board and State Aid Engineer, the Contractor shall have the charge and care thereof and shall take every precaution against injury or damage to any part thereof by action of the elements or from any other cause, whether arising from the execution or the non-execution of the work. The Contractor shall rebuild, restore, and make good, in accordance with the requirements of the contract, all injuries or damages to any portion of the work occasioned by any of the above causes before final acceptance and shall bear the expense thereof, except as provided in S-203.11 and as provided herein.

If the Engineer determines the work has been properly prosecuted, constructed, protected, and maintained, and damage is determined to be beyond the control and without fault or negligence of the Contractor, the Contractor will be paid for repairing such damage at the contract unit prices for applicable items involved in making repairs.

When contract items are not applicable to repair of work damaged from such cause, a supplemental agreement may be entered into, or such repairs may be accomplished under the provisions of S-109.04.

If the Engineer determines that such repair work has not been properly prosecuted and maintained, or if the Engineer determines that the Contractor has not taken all reasonable measures to provide adequate protection for partially completed or completed repair work, payment for repairs will not be made.

In case of suspension of work from any cause whatsoever, the Contractor shall be responsible for the project and shall take the precautions necessary to prevent damage to the project, provide for normal drainage, erect necessary temporary structures, signs, or other facilities; shall maintain the work in such a manner as to fully carry out his responsibility for maintaining traffic as required under the contract; shall properly and continuously maintain in an acceptable growing condition all living material in newly established plantings, seedings, and soddings furnished under the contract, and shall take adequate precautions to protect new trees and other vegetative growth against injury. Except when the suspension is ordered by the Engineer for the sole benefit of the Board, all such protection and maintenance shall be performed by the Contractor without additional cost to the County.

**S-107.18--Contractor's Responsibility for Utility Property and Services.** At points where the Contractor's operations are adjacent to or coincide with properties of railway, telegraph, telephone, and power companies, or are adjacent to or coincide with other property, damage to which might result in considerable expense, loss, or inconvenience, work shall not be commenced until all arrangements necessary for the protection thereof have been made.

All work to be performed within 50 feet either side of the centerline of any railroad track shall be executed in such manner and at such time that interference with the movements of trains or traffic upon the tracks of the Railroad Company is held to a minimum. The Contractor will be required to use all reasonable care and precaution in order to avoid accidents, damage, or unnecessary delays which would interfere with the Railroad Company's trains or other property.

The Contractor shall cooperate with the owners of all underground and overhead utility lines in their removal and rearrangement operations in order that these operations may progress in a reasonable manner and that duplication of rearrangement work may be reduced to a minimum, and that services rendered by those parties will not be unnecessarily interrupted.

In the event of interruption to utility services as a result of accidental breakage or as a result of being exposed or unsupported, the Contractor shall promptly notify the proper authorities and shall cooperate with them in the restoration of service. If water service is interrupted, repair work shall be continuous until the service is restored. No work shall be undertaken around fire hydrants until provisions for continued service have been approved by the local fire authority.

The Contractor is advised of Section 45-15-1, et seq., Mississippi Code of 1972, Annotated, regarding the performance of work in the proximity of high voltage overhead power lines. It is the Contractor's responsibility to comply with those statutory requirements.

**S-107.19--Furnishing Right-of-Way.** The Board will be responsible for the securing of all necessary rights-of-way prior to advertising for bids. Any exceptions will be indicated in the contract proposal.

**S-107.20--Personal Liability of Public Officials.** In carrying out any of the provisions of the contract, or in exercising the power or authority granted to them by or within the scope of the contract, there shall be no liability upon the Board, State Aid Engineer, County Engineer, or their authorized representatives, either personally or as officials of the County and State, it being understood that, in all such matters, they act solely as agents and representatives of the County and State.

**S-107.21--No Waiver of Legal Rights.** The Board and the State Aid Engineer shall not be precluded or estopped by any measurement, estimate, or certificate made either before or after the completion and acceptance of the work and payment therefor, from showing the true amount and character of the work performed and materials furnished by the Contractor, nor from showing that any such measurement, estimate or certificate is untrue or is incorrectly made, nor that the work or materials do not in fact conform to the contract. The Board and State Aid Engineer shall not be precluded or estopped, notwithstanding any such measurement, estimate, or certificate and payment in accordance therewith, from recovering from the Contractor or his Sureties, or both, within the provisions of the laws of the State of Mississippi, such damage as they may sustain by reason of the Contractor's failure to comply with the terms of the contract. Neither the acceptance by the Board and State Aid Engineer, or any of their representatives, nor any payment for or acceptance of the whole or any part of the work, nor any extension of time, nor any possession taken by the Board, shall operate as a waiver of any portion of the contract or of any power herein reserved, or of any right to damages. A waiver of any breach of the contract shall not be held to be a waiver of any other subsequent breach.

The Board and State Aid Engineer reserve the right to correct any error in any estimate that may have been paid on work that has been performed, and to adjust the same to meet the requirements of the contract and specifications. Upon conclusive proof of error or collusion or dishonesty, between the Contractor or his agents and the Engineer or his assistants being discovered after final payment has been made, the Board and State Aid Engineer reserve the right to claim and recover by process of law, sums as may be sufficient to correct the error or make good the defects in the work resulting from such errors, dishonesty, or collusion.

**S-107.22--Environmental Protection.** Occupancy by the Contractor or subcontractor of any lands, whether on or off the project right-of-way, for the performance of any work under the contract, or preparation therefor, shall be contingent upon provisions being made and carried out to prevent or minimize air pollution or water pollution and for the proper disposal of all toxic, hazardous, or other waste material. Each operation carried on by the Contractor shall include, as a part of that operation, the best management practices and effective use of temporary measures necessary to maintain ground surface conditions so as to prevent or minimize soil erosion, sedimentation, and water pollution which may degrade receiving waters including rivers, streams, lakes, reservoirs, tidal waters, groundwater and wetlands. The primary objective shall be to establish and maintain all permanent erosion control features as soon as possible.

**S-107.22.1--Section 404 Permits.** Work in waters of the United States or their adjacent wetlands requires a Clean Water Act (CWA) Section 404 Permit from the U.S. Army Corps of Engineers. Section 404 Nationwide Permits are available for activities with minimal adverse effects on the aquatic environment, including wetlands and streams. If an individual Section 404 permit or notification is required, it will be provided by the Board. These permits will be included in the contract when deemed necessary or made available for inspection in the office of the Engineer and the Office of State Aid Road Construction. The Contractor will be required to adhere to any stipulations, agreements, mitigation plans and associated best management practices required by the permit. If the Contractor proposes the use of construction methods that may result in changes to project impacts, then the Contractor will be responsible for coordinating the review and approval process, as may be required.

**S-107.22.2--National Pollutant Discharge Elimination System (NPDES) Permits.** The Mississippi Department of Environmental Quality (DEQ) is the NPDES permit authority for Mississippi. Construction that disturbs 1 acre or more, or less than 1 acre if part of a larger common plan of development or sale, requires permit coverage. The current Storm Water Construction General Permit (disturbs 5 or more acres) or the Storm Water Small Construction General Permit (disturbs 1 to 5 acres) issued by DEQ are hereby included by reference. They are available online at the DEQ web page and are revised and reissued every 5 years by DEQ. The Board will obtain permit coverage for each project as required.

The Contractor will be required to implement and adhere to the conditions included in the general permit and the project's Storm Water Pollution Prevention Plan (SWPPP) under the direction of the Engineer. It is the intent of the contract that construction storm water management be an integral part of all operations. Best management practices (BMP) for erosion and sediment control including silt fences, erosion control bales, check dams, berms, water bars, silt traps, silt basins, pipe slope drains, paved flumes, construction exits, temporary seeding, sodding, mulching, soil reinforcing mat, brush barriers, and other structural or non-structural practices shall be installed as shown on the plans and described in the project SWPPP. Estimated quantities and locations for the control measures will be shown on the plans. Failure to implement or maintain the SWPPP or comply with permit requirements may result in suspension of work (S-105.01) or withholding of estimates (S-109.06.4) by the Engineer.

**S-107.22.3--Payment.** Payment for satisfactory completion of the work such as installation, operation, maintenance, and removal of SWPPP construction items, shall be paid for directly as indicated on the plans. Other compliance related activities such as monitoring, good housekeeping, and best management practice construction techniques, will be absorbed as incidental items. If the Contractor is required to install temporary erosion, sediment and water pollution control measures due to his negligence, carelessness, lack of maintenance, or failure to install permanent controls as a part of the work as scheduled, and measures are ordered in writing by the Engineer, such work shall not be measured for payment but shall be performed at the Contractor's expense. In case of failure on the part of the Contractor to prevent and control soil erosion, sedimentation and water pollution which may degrade receiving water, the Engineer reserves the right to employ outside assistance or to use such forces as may be available to provide the necessary corrective measures. All costs including engineering costs will be deducted from any moneys due or that may become due the Contractor. Upon project completion, the county will submit the Notice of Termination to DEQ as required by the permit. A copy of the termination letter from DEQ shall be submitted to the Office of State Aid Road Construction prior to final acceptance.

**S-107.22.4--Storm Water Pollution Prevention Plan.** The SWPPP for each construction project that disturbs 1 or more acres and the Certificate of Permit Coverage for each project that disturbs 5 or more acres will be included as a supplement to this section in the contract documents.

**S-107.22.5--Contractor's Pollution Prevention Plan.** Before starting any work on the project, the Engineer may require the Contractor to submit for approval, schedules for installation, maintenance, and removal of temporary measures and establishment of permanent measures as required by the SWPPP and indicated on the plans, including a plan for the disposal of waste materials generated on the project site.

The Contractor may also be required to provide the Engineer a written plan of pollution control measures to be installed during Contractor operations in areas outside the right of way and any activities anticipated on the right of way that are not addressed in the SWPPP or the plans to support the Contractor's operations, such as material processing plants or handling areas, haul roads, field offices, equipment and supply areas, and material sources. This does not apply to commercial operations. After review of this plan, the Engineer may require the Contractor obtain separate construction storm water permit coverage from DEQ. Pollution control measures outside the right of way will not be measured for payment but shall be performed at the Contractor's expense.

The Contractor shall effectively prevent and control erosion and sedimentation on the site at the earliest practicable time as outlined in the approved schedule. Control measures, where applicable, will be implemented prior to the commencement of each construction operation or immediately after the area has been disturbed. The Contractor shall limit the amount of disturbed earth to that which can be effectively controlled. If, in the opinion of the Engineer, the Contractor is not able to effectively control soil erosion and sedimentation resulting from construction operations, the Engineer will limit the amount of disturbed area to that which the Contractor is able to control. Under no conditions shall the surface area of erodible earth exposed at one time by clearing and grubbing exceed 750,000 square feet without approval by the Engineer. After significant rainfall events, the Contractor will remove silt accumulations as soon as possible and deposit the material as approved by the Engineer.

Should the control measures fail to function effectively, the Contractor shall, without delay, act to bring the erosion and sedimentation under control by maintaining existing controls or by providing additional controls as directed by the Engineer. When in the opinion of the Engineer the site is adequately stabilized, temporary control measures will be removed and properly disposed of by the Contractor and the area restored or prepared for subsequent work.

**S-107.22.6--Clearing and Grubbing, Haul Roads on or off the Right-of-way, Waste Areas, Plant Sites, or Other Areas Occupied by the Contractor in Connection with the Work.** Clearing and grubbing on erodible areas, construction and maintenance of haul roads, plant sites, or other areas occupied by the Contractor in connection with the work shall include adequate protection by means selected by the Contractor and approved by the Engineer for preventing excessive erodible material from entering water or waterways off lands occupied by the Contractor and for preventing dust created by hauling equipment. Provisions for burning and dust and smoke control at plants are found elsewhere in these specifications.

Temporary erosion control measures as necessary shall be employed by the Contractor from the beginning of the work by the expeditious use of brush, vegetation or other residue from clearing and grubbing, temporary or permanent terraces, berms, dikes, dams, sediment basins, or other effective means of containing sediment. All temporary or permanent erosion control features shall be maintained in an effective manner so long as their use is essential to the abatement of siltation.

After temporary features are deemed to no longer be useful, such features shall be removed and the area restored or prepared for subsequent work.

All temporary protection from siltation and pollution resulting from clearing and grubbing, construction of haul roads, and other areas indicated herein shall be the responsibility of the Contractor, and measurement for direct payment for construction, maintenance, removal, and satisfactory disposal will not be made unless indicated on the plans or authorized by the Engineer. Under no conditions shall the surface area of erodible earth exposed at one time by clearing and grubbing exceed 750,000 square feet without approval by the Engineer.

**S-107.22.7--Pit Operations.** The Contractor shall schedule, arrange, and conduct clearing and grubbing operations, stripping, opening up of the source, and all mining and hauling operations, and shall finish and protect the surface of disturbed areas so as to prevent siltation or pollution of ditches, streams, lakes, reservoirs and adjacent property with sediment, fuels, oils, or other objectionable material resulting from his operations.

Unless otherwise specified, or permitted in writing, upon completion of operations, excavations, pits, or quarries shall be finished so that water will not collect or pond therein. Areas or surfaces of waste overburden or stripping shall be finished, neatly dressed and terraced or otherwise left in a satisfactory condition to prevent siltation and pollution of ditches, streams, lakes, reservoirs and adjacent property. All excavations, pits or quarries shall comply with the provisions of S-104.07 and S-106.02.1.



**S-107.22.8--Structures, Grading, and Other Construction.** The Contractor shall perform all work required under the contract in such manner and with such protective features as will contain undesirable siltation under control within the limits of the work. Performance in the designated or directed sequence and the providing of all erosion protection for which pay items are not included in the contract shall be considered as included in prices bid for the various pay items of the contract.

The Contractor shall employ all temporary or permanent measures necessary to prevent or minimize undesirable siltation in connection with the excavation for and the construction and backfill of structures. Such temporary measures as are indicated herein for clearing and grubbing, or other measures such as covering of excavated materials, lining channels, construction bulkheads, or other effective measures shall be employed.

The Engineer will limit the areas of excavation, borrow, and embankment operations in progress commensurate with the Contractor's capability and progress in keeping the finish grading, mulching, seeding, and other such permanent erosion control measures current. Should seasonal limitations make such coordination unrealistic, temporary erosion control measures shall be taken immediately to the extent feasible and justified. Under no conditions shall the surface area of erodible material exposed at one time by excavation, borrow, or fill within the right-of-way exceed 750,000 square feet without prior approval by the Engineer.

**S-107.22.9--All Operations.** It shall be fully understood that nothing in this subsection shall be construed in any manner to relieve the Contractor from any of his responsibilities for the establishment of permanent roadside development items and other permanent work specified for erosion control in the sequence and manner included in other provisions and requirements of the contract.

**S-107.23--Material Pits.**

- I. Bidders are reminded of the Mississippi Surface Mining and Reclamation Act and the Rules and Regulations adopted to implement this act. Questions or problems concerning the Act or the Rules and Regulations should be directed to the Department of Environmental Quality, Office of Geology, Department of Mining & Reclamation, P.O. Box 20307, Jackson, MS 39289-1307. Telephone Number: 601\961-5500
- II. In addition to complying with the Rules and Regulations pertaining to the Mississippi Surface and Reclamation Act, the Contractor shall take the following action on material pits to be developed for the work.

Before a pit is opened, furnish to the County Engineer a letter from the Executive Director of the Department of Archives and History, P. O. Box 571, Jackson, Mississippi 39205 (telephone number 601/359-6850), stating that the pit site is satisfactory from an archaeological and historical standpoint.

All costs involved in obtaining the letter of clearance shall be borne by the Contractor.

Delays encountered in obtaining the letter of clearance will not be considered as a reason for extension of contract time.

The Contractor is further reminded of the Clean Water Act Amendments requiring National Pollutant Discharge Elimination System (NPDES) permits for discharges composed entirely of storm water from active or inactive surface mining operations, excluding work areas covered by a U. S. Army Corps of Engineers Clean Water Act Section 404 Permit. Questions or problems concerning NPDES permits should be directed to the Mississippi Department of Environmental Quality (MDEQ), Office of Pollution Control, Industrial Branch, Jackson, Mississippi.

The Contractor shall, before a regulated area is opened or enlarged as a material pit, obtain from MDEQ the necessary Mining Storm Water NPDES Permit(s) authorizing the discharge of storm water subject to the terms and conditions of said permit. All costs involved in obtaining the permit(s) shall be borne by the Contractor. Delays encountered in obtaining the permit(s) will not be a reason for extension of contract time.

For regulated commercial sources, the owner(s) shall bear the responsibility for meeting the requirements of the NPDES permitting process.

**S-107.24--Construction Noise Abatement.** The Contractor shall comply with all state and local sound control and noise level rules, regulations and ordinances which apply to any work performed pursuant to the contract.

Each internal combustion engine, used for any purpose on the work or related to the work, shall be equipped with a muffler of a type recommended by the manufacturer. No internal combustion engine shall be operated on the project without such muffler.

**S-107.25--Hazardous and/or Toxic Waste Procedures.** No matter how extensive a field investigation, the possibility exists that hazardous and/or toxic wastes on a site will go undetected until excavation is initiated. If underground storage tanks (USTs), buried containers, hazardous and/or toxic substances are uncovered - or even suspected - during construction, work in this area shall be immediately discontinued and measures taken to protect susceptible nearby wetlands or ground-water sources.

It is essential that the suspected hazardous substances be left in place until they have been identified. The Contractor shall make every effort to prevent his personnel, State and County personnel and the general public from becoming exposed to substances that may be hazardous or toxic. Once contaminated soil or debris has been removed from the ground and leaves the site, it is considered a hazardous waste (if the concentration exceeds regulatory levels). In such cases, the Contractor becomes a hazardous waste generator, and the County becomes subject to the provisions of the Resource Conservation and Recovery Act (RCRA).

Disposition of all underground storage tanks (USTs), containers, hazardous and/or toxic waste shall be in accordance with current rules and regulations of the Department of Environmental Quality, Office of Pollution Control.

The Contractor shall report to the Engineer and the Office of Pollution Control any evidence or conditions which may cause suspicion that a waste site of hazardous or toxic materials and/or containers or USTs has been located within right-of-way limits of the construction project. Work shall cease immediately at such suspected site and shall not resume until directed by the Engineer.

When the Contractor is required to perform additional work to dispose of such waste, containers and/or USTs, payment will be made at contract unit prices which are applicable to the work and/or as provided in S-104.02 or S-109.04 when the contract does not include appropriate pay items.

The County reserves the right to use other forces for exploratory work to identify and determine the extent of hazardous and/or toxic waste. Should the disposition of such material require special procedures by certified personnel, the County will make arrangements with qualified persons to dispose of the material.

When the existence of USTs are known in advance of construction activity, the Contractor shall give the Office of Pollution Control written notification 30 days in advance of removal.

When an underground storage tank contains or has been used for containment of a regulated substance and the Contractor is required to remove such tank in accordance with the provisions of S-104.05, the Contractor shall not use "flotation" as a method of removal.

**S-108.01--Subletting of Contract.**

**S-108.01.1--General.** The Contractor shall perform with his own organization contract work amounting to at least 40 percent of the value of the original total contract, except that the contract value of items designated as Specialty Items will be deducted from the original total contract price before computing the value of work required to be performed by the Contractor with his own organization. The Contractor's "own organization" shall be construed to include only workmen employed and paid directly by him and equipment owned or rented by him, with or without operators. All items that have been selected as specialty items will be listed as such in the proposal for the work.

The Contractor shall not sublet any portion of the contract, or of the work provided therein, except the furnishing of necessary materials, without written approval of the Board and State Aid Engineer.

Consideration will be given to requests to sublet a portion of the total value of a contract pay item. When the Contractor proposes to sublet a portion of a pay item, the Contractor's request shall be accompanied by a breakdown of the costs of the various components (including haul if applicable) of each pay item that is proposed to be sublet by part.

Computation of the percentage of the work sublet shall be based on the contract price of each item or in the case of subletting a part of a pay item, the percentage shall be based on the amount acceptably established by the Contractor.

The simple expediency of carrying the workmen of another Contractor on the Contractor's or approved subcontractor's payroll to avoid subcontracting will not be permitted.

Subcontracting does not release the Contractor of bond and contract liability and shall not be construed to imply that a contract exists between the County and a third party.

The Contractor must pay subcontractor(s) for satisfactory performance of their contracts no later than 15 calendar days from receipt of payment from the Office of State Aid Road Construction. Within 15 calendar days after receiving payment from the Office of State Aid Road Construction for work satisfactorily performed, the Contractor shall make prompt payment to all sub-contractors or material suppliers for all monies due. Within 15 calendar days after receiving payment from the Office of State Aid Road Construction for work satisfactorily completed, the Contractor shall promptly return all retainage monies due to all sub-contractors or material suppliers.

**S-108.02--Notice to Proceed.** The Contractor shall not begin construction on any feature of the work before a Notice to Proceed is issued by the Engineer. The Notice to Proceed will stipulate the date upon which it is expected that the Contractor will begin work, and from which date Contract Time will begin.

The Contractor will be expected to begin work on or before the date specified in the Notice to Proceed for the beginning of Contract Time. Contract Time will begin on the date specified in the Notice to Proceed, unless operations begin at an earlier date wherein labor, or labor and equipment, is employed in work which would show on the Contractor's payroll forms; in which case the date that such operations are begun shall apply.

In the event the Engineer has not issued the Notice to Proceed within thirty (30) calendar days after the State Aid Engineer approves the contract, the Notice to Proceed will automatically take effect on day thirty-one and Contract Time will begin on the third Monday occurring after the Notice to Proceed has taken effect unless work begins at an earlier date in which case Contract Time will begin on the day work begins.

Failure of the Contractor to commence work by the date specified for the beginning of contract time, or within a short time thereafter considered by the Board and State Aid Engineer to be reasonable, may be cause for annulment of the contract.

**S-108.03--Prosecution and Progress.** The work shall begin and shall be prosecuted diligently at such rate, with such materials, equipment, labor, and supervision as is considered necessary to ensure its completion within the time set forth in the proposal and contract. Unless otherwise instructed by the Engineer each operation shall be begun as soon after the Notice to Proceed is issued as conditions will permit. Each class of work will be expected to progress from the date it is begun until completed. During the progress of the work the Contractor shall notify the Engineer sufficiently in advance of the time in which he expects to undertake any work. Should the work, for any reason, be discontinued by the Contractor, he shall notify the Engineer in writing at least twenty-four (24) hours before again resuming work.

The Contractor, upon request of the Engineer, shall furnish the Engineer with a schedule of his proposed construction operations, which schedule shall clearly set forth the sequence and estimated time for performing the principal elements of the work.

**S-108.04--Limitations of Operations.**

**S-108.04.1--General.** Each item of construction shall be prosecuted to completion without delay, and the Contractor shall not transfer equipment or forces from uncompleted construction without written approval from the Engineer.

Work requiring the presence or services of Engineering personnel will not be permitted on Sunday, New Year's Day, Independence Day, Labor Day, Thanksgiving Day and Christmas Day, unless the Engineer determines that an emergency or necessity exists. Work on these days, in lieu of supplemental equipment and labor, solely to complete the project within contract time will not be considered a necessity or emergency.

Drainage and minor structures shall be completed ahead of grading to ensure proper setting and curing, thorough compaction of backfill, and improved soil conditions for proper embankment construction.

When in the judgement of the Engineer, the Contractor has initiated construction on a greater portion of the work than is necessary for proper prosecution, or is carrying on operations to the prejudice of work already started, the Engineer may require the Contractor to finish the part on which work is in progress before additional portions are started. Work shall be conducted in the manner and sequence necessary to provide for public convenience and safety as set out in S-107.07.

**S-108.04.2--Night Work.** When it is important that some particular phase of construction be pushed to early completion for the public benefit or in the case of emergencies and when not specifically prohibited by the specifications, the Engineer may permit construction after daylight hours. If night work is permitted, the Contractor shall provide sufficient illumination as determined by the Engineer, and the work performed under these conditions shall comply in every respect with the terms and conditions of the contract.

**S-108.04.3--Temporary Suspension of Work.** The Engineer, with the approval of the State Aid Engineer, will have the authority to suspend the work wholly or in part for as long as necessary because of unsuitable weather, unusually heavy traffic, or other conditions unfavorable for the satisfactory prosecution of the work, or for failure of the Contractor to carry out instructions or to perform all provisions of the contract. If it becomes necessary to stop work for an indefinite period, the Contractor shall store all materials so that they will not obstruct or impede the traveling public or become damaged in any way. He shall take every precaution to prevent damage or deterioration of the work performed; provide suitable drainage of the roadway; and erect temporary structures where necessary. The Contractor shall not suspend work without written authority from the Engineer. Contract time will not be charged for phases of work suspended by the Engineer, but no additional compensation will be paid the Contractor because of such suspension.

If the performance of all or any portion of the work is suspended or delayed by the Engineer in writing for an unreasonable period of time (not originally anticipated, customary, or inherent to the construction industry) and the Contractor believes that additional compensation and/or contract time is due as a result of such suspension or delay, the Contractor shall submit to the Engineer in writing a request for adjustment within 7 calendar days of receipt of the notice to resume work. The request shall set forth the reasons and support for such adjustment.

Upon receipt, the Engineer will evaluate the Contractor's request. If the Engineer agrees that the cost and/or time required for the performance of the contract has increased as a result of such suspension and the suspension was caused by conditions beyond the control of and not the fault of the Contractor, its suppliers, or subcontractors at any approved tier, and not caused by weather, the Engineer, with the approval of the State Aid Engineer, will make an adjustment (excluding profit) and modify the contract in writing accordingly. The Engineer will notify the Contractor of his/her determination whether or not an adjustment of the contract is warranted.

No contract adjustment will be allowed unless the Contractor has submitted the request for adjustment within the time prescribed.

No contract adjustment will be allowed under this clause to the extent that performance would have been suspended or delayed by any other cause, or for which an adjustment is provided for or excluded under any other term or condition of this contract.

**S-108.05--Character of Employees, Methods, and Equipment.** The Contractor shall employ only competent and efficient laborers, mechanics, or artisans, and whenever any employee is deemed to be careless or incompetent, or obstructs the progress of the work, or is intemperate, uncooperative or disorderly, the Contractor shall, upon written request of the Engineer, discharge or otherwise remove such employee from the work and shall not employ that employee again on the work without the written consent of the Engineer.

The methods used in performing the construction and all equipment, tools, and machinery used for handling materials and executing any part of the construction shall be subject to the approval of the Engineer before the construction is started, and whenever found unsatisfactory shall be changed and improved as required by the Engineer. All equipment, tools, and machinery used shall be maintained in a satisfactory working condition.

The measure of the capacity and efficiency of machinery and equipment shall be its actual performance on the work. Should it become apparent that the progress of construction is such that the Contractor will be unable to complete the work with the available equipment within the contract time, the Engineer may require that additional equipment, meeting his approval, be placed on the work.

Permission to use alternative equipment, in lieu of equipment specified, may be granted when such equipment is of a new or improved type and its use is deemed by the Engineer to be in furtherance of the intent of these specifications. Continued use of such alternative equipment on any project shall be contingent upon its capability to produce work consistently equal to, or better than, that which can be produced with the equipment specified.

Nothing in this subsection shall relieve the Contractor of his responsibility for producing finished work of the quality specified in the contract. Should the Contractor continue to employ or reemploy such unsatisfactory person or persons as herein described, or fail to furnish suitable and sufficient machinery, equipment, or forces for the proper prosecution of the work, the Engineer may withhold all estimates which are, or may become, due until his orders are complied with, or the contract may be declared in default as hereinafter provided.

**S-108.06--Determination and Extension of Contract Time.** The number of days allowed for the completion of the work included in the contract will be stated in the proposal and contract, and will be known as the "Contract Time."

Each month the Engineer will furnish the Contractor with a "Partial Monthly Report" showing the number of working days he has determined were used or charged during the monthly period. The charging of any working day(s) as indicated on the County Engineer's Monthly Report shall be deemed to have been accepted by the Contractor as correct unless the Contractor shall, by the 15th of the following calendar month, file with the Engineer his written protest setting forth his objections to the working day count and his reasons therefor. He shall state his reasons in writing, furnish proof to establish his claim and state the number of days (showing dates) for which he claims he should not be charged working days.

The number of days for performance allowed in the contract as awarded is based on the quantities used for comparison of bids. If satisfactory fulfillment of the contract requires performance of work in greater quantities than those set forth in the proposal, the contract time allowed for performance shall be increased on a basis commensurate with the amount and difficulty of the added work.

If the Contractor finds it impossible, for reasons beyond his control, to complete the work within the contract time as specified or as extended in accordance with the provisions of this Subsection, he may make a written request to the Engineer for an extension of time setting forth therein the reasons which he believes will justify the granting of his request. The Contractor's plea that insufficient time was specified is not a valid reason for extension of time. If the Engineer finds that the work was delayed because of conditions beyond the control and through no fault of the Contractor, he may recommend to the Board and State Aid Engineer an extension of time for completion in such amount as the conditions justify. When approved, the extended time for completion shall then be in full force and effect the same as though it were the original time allowed for completion.



**S-108.07--Failure to Complete the Work on Time.** Should the Contractor fail to complete the work in the time stipulated in the contract, or within the extended time as may have specifically been allowed under the provisions of S-108.04.3 (Temporary Suspension of Work) or S-108.06 (Determination and Extension of Contract Time), a deduction of the amount as calculated from the daily charges given in the table below will be made as Liquidated Damages for the additional time over and above that designated for completion of the work. The daily charges set out in the table for Liquidated Damages herein below are based on and are approximately the average cost to the County and to the State for maintaining Engineers, Inspectors and other employees on work of the applicable magnitude and for making necessary trips to inspect the quality and progress of the work.

The deduction so calculated from the table is hereby agreed upon as Liquidated Damages for the loss to the County and to the State on account of the additional expense of maintaining Engineers, Inspectors and other employees on the work and for making necessary trips to inspect the quality and progress of the work after the expiration of the contract time. This deduction for additional engineering expenses will be made from any money due the Contractor under the contract. The Contractor and his Sureties shall be liable for any liquidated damages in excess of any amount due the Contractor. Acceptance of any progress payments accompanying any estimate, without written protest, shall be an acknowledgement by the Contractor that the number of accumulated working days and the amount of Liquidated Damages shown on such estimate are correct. Permitting the Contractor to continue to finish the work, or any part of it, after the time fixed for its completion, or after the date to which the time of completion may have been extended, or at any time, shall in no way operate as a waiver on the part of the County and State of any of its rights under the Contract.

Schedule of Deductions For Each Day of Overrun  
in Contract Time

Original Contract Amount	From More Than (\$)	To and Including (\$)	Daily Charge Per Work Day (\$)
	0	25,000	100
	25,000	50,000	120
	50,000	100,000	140
	100,000	500,000	200
	500,000	1,000,000	300
	1,000,000	2,000,000	400
	2,000,000	5,000,000	650
	5,000,000	10,000,000	750
	10,000,000	—	1,400

**S-108.08--Default and Termination of Contract.** The contract, of which these specifications form a part, may be terminated by the Board and State Aid Engineer for any of the following reasons:

- (A) Evidence that progress being made by the Contractor is not substantially in conformity with the required progress for respective periods of contract time as follows:
- (1) At least 10% of the work completed at the end of the first period (one quarter of contract time).
  - (2) At least 45% of the work completed at the end of the second period (one-half of contract time).
  - (3) At least 70% of the work completed at the end of the third period (three-quarters of contract time).
  - (4) At least 100% of the work completed at the end of the fourth period (end of contract time).

- (B) Failure on the part of the Contractor to proceed with the construction of the project when so instructed by the Engineer, or to observe any requirements of these specifications.
- (C) Violation on the part of the Contractor of labor provisions and special regulations.
- (D) The Contractor's performing the work unsuitably or neglecting or refusing to remove materials or to perform anew such work as may be rejected or unacceptable and unsuitable.
- (E) The Contractor's becoming insolvent or being declared bankrupt or committing any act of bankruptcy or insolvency.
- (F) The Contractor's failing to perform the work with sufficient workmen and equipment or with sufficient materials to assure the prompt completion of the work.
- (G) The Contractor's discontinuing the prosecution of the work.
- (H) The Contractor's allowing any final judgment to stand against him unsatisfied.
- (I) The Contractor's making an assignment for the benefit of creditors.
- (J) The Contractor's failure for any other cause whatsoever to carry on the work in an acceptable manner.

Before the contract is terminated, the Contractor and his Surety will be notified in writing by the Board and State Aid Engineer of the conditions which make termination of the contract imminent. If, for any reason, written notice cannot be delivered to the Contractor, notice of termination may be given by publication in a newspaper in the county in which the project is located; or if there is no such newspaper, the notice may be given by publication in a newspaper located in Hinds County.

If no effective effort has been made by the Contractor or his Surety to correct the conditions of which complaint is made within 15 calendar days after notice is given, the Board and the State Aid Engineer may declare the contract terminated and notify the Contractor and his Surety accordingly.

Upon receipt of notice from the Board and State Aid Engineer that the contract has been terminated, the Contractor shall immediately discontinue all operations.

After termination, the Board and State Aid Engineer will order the Surety to arrange for the prosecution of the work. If the Surety does not proceed with the satisfactory prosecution of the work within twenty (20) calendar days from the date on which the contract was terminated, the Board and the State Aid Engineer may proceed by either readvertising and awarding a new contract, or in any other lawful manner which will provide for the completion of the work as planned and set forth in the contract. After the contract has been declared terminated, the Surety, or the Board with the approval of the State Aid Engineer, at the Surety's expense, will perform or arrange for necessary maintenance between the date of termination and the date that work is resumed by arrangement made by the Surety or by the Board and State Aid Engineer. When the work is finally completed the total cost will be computed. When this cost, regardless of the method used to complete the work, is less than the total cost which would have resulted at the original contract unit prices, the difference will be paid to the original Contractor's Surety. When the total cost is greater than the total cost which would have resulted at the original contract unit prices, the difference shall be paid by the original Contractor's Surety.

**S-108.09--Termination of Contract for Reasons Other Than Default.** The Board and State Aid Engineer by and with the consent of the Federal Highway Administration, where applicable may by written order, terminate the contract or any portion thereof after determining that for reasons beyond either Board or Contractor control the Contractor is prevented from proceeding with or completing the work as originally contracted, and that termination would therefore be in the public interest. Such reasons for termination may include, but need not be necessarily limited to, executive orders of the President relating to prosecution of war or national defense, national or area emergencies which create a serious shortage of materials, orders from duly constituted authorities relating to energy conservation, and restraining orders or injunctions obtained by third-party citizen action resulting from national or local environmental protection laws or where the issuance of such order or injunction is primarily caused by acts or omissions of persons or agencies other than the Contractor.

For purposes of this contract "Area Emergency" shall be understood to be an emergency created by an acute shortage of materials, supplies, labor, or equipment within an area in which the project is located and termed usually as the "Trade Area."

Specifically for the purpose of this provision, the "Area" under consideration shall be understood to be the area from which the Board and State Aid Engineer determines the Contractor would reasonably obtain materials, supplies, labor, or equipment, respectively.

When the Board, with the approval of the State Aid Engineer, orders termination of a contract effective on a certain date under this subsection, all completed items of work as of that date will be paid for at the contract unit price. Payment for partially completed work will be made either at agreed prices or by force account as described elsewhere in these specifications. Items which are eliminated in their entirety will be paid for as provided in S-109.05.

Acceptable materials, obtained by the Contractor for the work but which have not been incorporated therein, shall be disposed of as mutually agreed.

After receipt of Notice of Termination under this subsection from the Board and State Aid Engineer, the Contractor shall submit, within 10 days of the effective termination date, his claim for additional damages or costs not covered herein or elsewhere in these specifications. Such claim may include such cost items as reasonable idle equipment time, mobilization efforts, bidding and project investigative costs, overhead expenses attributable to the project, legal and accounting charges involved in claim preparation, subcontractor costs not otherwise paid for, actual idle labor cost if work is stopped in advance of termination date, guaranteed payments for private land usage as part of original contract, and any other cost or damage item for which the Contractor feels reimbursement should be made. The intent of negotiating this claim would be that an equitable settlement figure be reached with the Contractor. In no event, however, will loss of anticipated profits be considered as part of a settlement. The Contractor shall make his cost records available to the extent necessary to determine the validity and amount of each item claimed.

Termination of a contract or portion thereof will not relieve the Contractor of his contractual responsibilities for the work completed, nor will it relieve the Surety of its obligation for and concerning any just claim arising out of the work performed.

**S-108.10--Termination of Contractor's Responsibility.** The contract will be considered complete when all work has been satisfactorily completed, satisfactory test reports are available on all materials used in the project, the final inspection made, the work accepted by the Board and State Aid Engineer and the final estimate paid. When the Board and State Aid Engineer write the formal letter of acceptance, the Contractor will be released from further obligation except as set forth in his contract bond or as provided by law.

**S-109.01--Measurement of Quantities.** The measurement and determination of quantities of each pay item will be made in general as prescribed hereinafter, and specifically as set out under Method of Measurement and Basis of Payment in the specifications for each pay item. Actual authorized quantities of work completed under the contract will be measured by the Engineer according to United States standard measures, and in accordance with well recognized engineering practices. Unauthorized wastage of material will be deducted, and only quantities actually incorporated in the completed work or ordered to be wasted will be included in the final estimate.

A station when used as a definition, term or measurement will be one hundred (100) linear feet.

Unless otherwise specified, longitudinal measurements for area computations will be made horizontally, and no deductions will be made for individual fixtures having an area of nine square feet or less. Unless otherwise specified, transverse measurements for area computations will be the neat dimensions shown on the plans or ordered by the Engineer.

Where the area unit for measurement and payment is specified for erosion control items, the measurements will be taken on the slope of the ground to compute the actual surface area for payment.

Structures will be measured according to neat lines shown on the plans or as altered to fit field conditions.

All items which are measured by the linear foot, such as pipe culverts, guardrail, underdrains, etc., will be measured as specified under the Method of Measurement for the item unless otherwise shown on the plans.

No payment will be made for unauthorized excavation. Excavation or embankment performed beyond the required neat lines, or slope stakes, will not be measured for payment except as elsewhere provided herein or when within tolerances specified.

In computing volumes of excavation and embankment, the average end area method will be used, unless otherwise specified.

The term gage, when used in connection with the measurement of plates, will mean the U. S. Standard Gage, except that when reference is made to the measurements of galvanized sheets used in the manufacture of corrugated metal pipe, metal plate pipe culverts and arches, and metal cribbing, the term gage will mean that specified in the AASHTO Designation: M 36 or M 167.

When the term gage refers to the measurement of wire, it will mean the gage specified in the AASHTO Designation: M 32.

The term ton will mean the short ton consisting of 2000 pounds avoirdupois. All materials which are specified for measurement by the ton shall be weighed by competent personnel on accurate, approved scales set at locations approved by the Engineer. If material is shipped by rail, the car weight may be accepted provided the actual weight of material only will be paid for, and not minimum car weight used for assessing freight tariff. However, car weights will not be acceptable for material to be passed through mixing plants. Trucks used to haul material being paid for by weight shall be weighed empty daily at such time as the Engineer directs, and each truck shall bear a plainly legible identification mark.

Timber will be measured by the thousand feet board measure (MBM) actually incorporated in the structure. Measurement will be based on nominal widths and thicknesses and the extreme length of each piece.

When a complete structure or structural unit (in effect, "lump sum" work) is specified as the unit of measurement, the unit will be construed to include all necessary fittings and accessories.

Volumes of materials computed in cubic yards by the average end area method are designated as "Final Measure" (FM), "Final Measure Embankment" (FME) or "Plan Measure" (PM). Volumes of materials designated for measurement loose in the vehicle are designated as "Loose Vehicle Measure" (LVM).

Volumetric measurement of excavation, embankment, granular materials, or similar materials in cubic yards will be made by the methods (see below) designated on the plans or in the proposal. For justifiable reasons, such as impracticability of measurement of volumes (usually small) by the designated method, the Engineer may order measurement by another method as follows:

- (1) Volumes designated for payment by FM may be measured LVM, and converted to contract measurement by multiplying the loose measure by eighty percent.
- (2) Volumes designated for payment by LVM may be measured at the source by the average end area method and converted to contract measurement by multiplying the FM measure by one hundred twenty-five percent.
- (3) Volumes designated for payment by FME may be measured in its original position by the average end area method and multiply the FM measure by 90 percent.

- (4) Small volumes of surplus, excess excavation or other small volumes of excavation which are impractical to measure by the average end area method but are designated to be measured by FME may be measured LVM and multiply the loose measure by 72 percent.

When any of the above conversion measurements are ordered by the Engineer, the method of measurement shall be deemed acceptable to all parties and shall be final.

When the average end area method is indicated, other three dimensional measurements of the prismoid occupied by the material in its natural position before removal, may be used.

When requested by the Contractor and approved by the Engineer in writing, materials specified to be measured by the cubic yard or ton may be converted to the other measure as appropriate. Factors for conversion from weight measurement to volume measurement or from volume measurement to weight measurement, will be determined by the Engineer and shall be agreed to by the Contractor before such method of measurement of pay quantities is used.

All materials for which measurements are obtained by the cubic yard LVM shall be hauled in approved vehicles and verified therein at the point of delivery. Approved vehicles for this purpose may be of any size or type acceptable to the Engineer, provided the body is of such shape that actual delivered contents may be readily and accurately determined to the whole cubic yard. Unless all approved vehicles on the work are of uniform capacity, each vehicle must bear a plainly legible identification mark, indicating its measured capacity.

All vehicles shall be loaded to a sufficient level to ensure a water level load when the vehicles arrive at the point of delivery. Loads not hauled in approved vehicles, or of a quantity less than the measure quantity for the hauling vehicles, will be subject to rejection.

Bituminous materials will be measured by the gallon or ton. Volumes will be measured at 60° F or will be corrected to the volume at 60° F using tables in State Aid's SOP.

**S-109.02--Scope of Payment.** The compensation, as herein provided, constitutes full payment for the complete work, including all materials, labor, tools, equipment, and incidentals necessary for performing all work contemplated and embraced under the contract; for all loss or damage arising out of the nature of the work; for all loss from the action of the elements, except as otherwise provided; for any unforeseen difficulties or obstruction of the work which may arise or be encountered during the prosecution of the work until its final acceptance; for all risks connected with the prosecution of the work; for all expenses incurred by or in consequence of suspension or discontinuance of the work as herein specified, or for any infringement of patents, trademarks, or copyrights; and for completing the work in an acceptable manner according to the plans and specifications.



If the "Basis of Payment" clause in the specifications relating to any pay item in the contract requires that the contract unit price cover and be considered compensation for certain work or material essential to the item, this same work or material will not also be measured or paid for under any other pay item which may appear elsewhere in the specifications.

The payment of any current estimate, prior to final acceptance of the work by the Board and State Aid Engineer, shall in no way constitute acceptance of the work, nor in any way affect the obligation of the Contractor to repair or renew defective parts of the work. The Engineer will be the judge of defects or imperfections, and the Contractor shall be liable to the County and State for failure to correct same as provided herein.

**S-109.03--Compensation for Altered Quantities.** Whenever the quantity of any pay item is increased or decreased from the original contract quantity, payment for the item will be made on the basis of the actual quantity completed at the contract unit price, except as otherwise provided in S-104.02, in the detailed specifications for the particular pay item or by supplemental agreement.

**S-109.04--Extra and Force Account Work.** Extra work performed in accordance with the requirements and provisions of S-104.03 will be paid for at the unit prices or lump sum stipulated in the agreement authorizing the work, or the Board with the approval of the State Aid Engineer may require the Contractor to do such work on a force account basis to be compensated in the following manner:

- (1) **Labor.** For all labor and foremen in direct charge of the specific operations, the Contractor will receive the rate of wage (or scale) agreed upon in writing before beginning work for each hour that labor and foremen are actually engaged in such work.

An amount equal to fifteen (15) percent of the sum of the above item will also be paid the Contractor.

- (2) **Bond, Insurance, and Tax.** For property damage, liability, and workmen's compensation insurance premiums, unemployment insurance contributions and social security taxes on the force account work, the Contractor will receive the actual cost, to which cost no percentage will be added. The Contractor shall furnish satisfactory evidence of the rate or rates paid for the bond, insurance, and tax.
- (3) **Materials.** For materials accepted by the Engineer and used, the Contractor will receive the actual cost of the materials, including transportation charges paid by him (exclusive of machinery rentals as hereinafter set forth), to which cost fifteen (15) percent will be added.

- (4) Equipment. For any machinery or special equipment (other than small tools) authorized by the Engineer, the Contractor will receive the rental rates agreed upon in writing.

In the event an agreement cannot be reached for a particular piece of equipment, the pamphlet entitled "Construction Equipment Ownership and Operating Expense Schedule, Region III" as published by the Department of Army, U.S. Army Corps of Engineers, current at the time the force account work is authorized, will be used to determine equipment ownership and operating expense rates. These rates do not include allowances for operating, labor, mobilization or demobilization costs, overhead or profit, and do not represent rental charges for those in the business of renting equipment. Operating labor and overhead cost will be allowed. Subject to advance approval of the Engineer, actual transportation cost for a distance of not more than 200 miles will be reimbursed for equipment not already on the project. The cost of transportation after completion of the force account work will be reimbursed except it cannot exceed the allowance for moving the equipment to the work.

The hourly use rates are computed on the basis of a 40-hour work week. When the Contractor works more than 40 hours per week, the cost for "Cost of Facilities Capital" will be excluded from the hourly rate for those hours in excess of 40 hours per week.

No more than eight hours of standby will be paid during a 24-hour day, nor more than 40 hours per week. Standby time will not be allowed unless the equipment has been in idle status in excess of 16 hours during a 24-hour day. Likewise, standby will not be allowed during periods when the equipment would have otherwise been in idle status. Actual operating time during a week will be credited against the 40 hours maximum standby allowance.

All equipment shall be subject to approval from day to day in accordance with the requirements of S-108.05.

- (5) Miscellaneous. No additional allowance will be made for general superintendence, the use of small tools, or other costs for which no specific allowance is herein provided.

- (6) Compensation. No extra work on a force account basis will be paid for unless unit prices for labor, materials, and equipment rentals have been agreed upon in writing before work is started. In no case shall the unit prices paid to the Contractor exceed the amount of the quoted unit price for each item stipulated in the Force Account agreement.

The Contractor, or his authorized representative, and the Engineer shall compare records of extra work done on a force account basis at the end of each day. Copies of these records shall be made upon the form provided for this purpose, and shall be certified to by the Contractor and the Engineer. The Contractor shall furnish to the Engineer itemized statements of the cost of all force account work. The statements shall include a true copy of the payroll and the original receipted bills and invoices for the material used and the freight charges paid on same. Where materials used are not specifically purchased for use on extra work but are taken from the Contractor's stock, the Contractor may submit an affidavit of the quantity, price, and freight on these materials in lieu of certified copies of original bills and invoices. Statements covering force account work for each specific agreement shall be submitted promptly at the end of the month in which the work was actually completed.

**S-109.05--Eliminated Items.** Should any item contained in the proposal be found unnecessary for the proper completion of the work, the Engineer may, upon written order to the Contractor, eliminate the item from the contract and in no way invalidate the contract. When the Contractor is notified of the elimination of items, he will be reimbursed for actual work done and all costs incurred prior to the notification as provided in S-104.02.

**S-109.06--Partial Payments.**

**S-109.06.1--General.** Monthly estimates will be authorized by the Engineer provided the amount due on completed work is at least \$1,000.00 including advancement on materials. The monthly estimate will be prepared by the Engineer on the day of the month prescribed by the State Aid Engineer. Partial payments based on monthly estimates and computed at contract unit prices will be made on or about the day prescribed by the State Aid Engineer.

If defective work and/or materials are discovered or reasonable doubt arises as to the integrity of any part of the work for which partial payment has been allowed, a deduction from subsequent estimates in an amount equal to the value of the defective or questioned work will be made until the defects have been remedied or the causes for doubt removed.

**S-109.06.2--Advancement on Materials.** Partial payments for materials delivered and stockpiled on the project will not normally be made until they are incorporated in the work.

Upon written request of the Contractor, written consent of the Surety, approval by the Board and the Engineer and the State Aid Engineer reserving the final decision, advance payments for bulky non-perishable durable materials constituting significant portions of the project cost stored and stockpiled on or near the project or at other locations approved by the Engineer may be allowed. Borrow material, granular materials, topsoil, living or perishable plant materials and seeds are not to be considered for partial payment, nor will partial payments be made on relatively small quantities of materials. If partial payment is allowed, such payment will be based on the verified actual material costs plus the freight charges (excluding sales tax, local hauling and handling costs) without regard to percentage of completion of work. Estimates will not be allowed until the County Engineer receives duplicate copies of material invoices plus a testing engineer's certification. In all cases the Contractor shall save harmless the Board and State Aid Engineer in event of loss or damage, regardless of cause, as a result of such advance payments.

As the materials are incorporated into the work in accordance with specification requirements proportionate reductions for advanced payments shall be made from the monthly estimates covering the work performed. Calculation of percentage of completion, or rate of progress, shall be based on completed work and no consideration shall be given to inclusion of stockpiled materials in such calculations.

**S-109.06.3--Retainage.** No less than two and one-half percent (2 ½ %) nor more than ten percent (10 %), as determined by the State Aid Engineer, of the total of each monthly estimate will be deducted and retained until after the completion of all work in the contract, and the balance, less all previous payments, will be certified by the Engineer. Should the Engineer determine that satisfactory progress and/or performance is not being made on the project, the percent of retainage may be increased within the above limits with approval of the State Aid Engineer. The monthly estimates will be approximate only, and all estimates and payments will be subject to correction following discovery of error in any previous estimate. When all work has been completed the Engineer may, with the approval of the State Aid Engineer and consent of the Surety, reduce the retainage to two and one-half percent of the total amount earned.

Should defective work or materials be discovered or should reasonable doubt arise as to the integrity of any part of the work completed previously, there will be deducted from subsequent estimates an amount equal to the value of the defective or questioned work, and this work will not be included for payment until the defects have been remedied or the causes for doubt removed.

**S-109.06.4--Withholding of Estimates.** An estimate may be withheld indefinitely until all directions given by the Engineer, in compliance with and by virtue of the terms of the contract, have been complied with by the Contractor.

**S-109.07--Payment for Material on Hand.** See S-109.06.2.

**S-109.08---Changes in Material Costs.** Because of the uncertainty in estimating the costs of petroleum products that will be required during the life of a contract, adjustment in compensation for certain materials is provided as follows:

**Bituminous Products--** Each month the Department will acquire unit prices from producers or suppliers who supply the State highway construction industry with bituminous products. The average of all quotes for each product will serve as the base price for contracts let in the subsequent month.

**Fuels --** Selected cash price quotations for bulk gasoline and diesel fuel will be taken from Platt's Oilgram PAD 2 and PAD 3. The appropriate adjustment per gallon for gasoline and diesel fuel will be added to the quotations to allow for taxes and markups. The prices thus determined will serve as the base prices for contracts let in the subsequent month.

The established base prices for bituminous products and fuels will be included in the contract documents under a Notice to Bidders entitled "Petroleum Products Base Prices For Contracts Let In (Month and Year)."

Each month thereafter the Engineer will be furnished with the current monthly prices. Adjustments for change in cost will be determined from the difference in the contract base prices and the prices for the period that the work is performed and for the quantities completed provided the price change in a product is more than five percent (5%). Adjustments may increase or decrease compensation depending on the difference between the base prices and prices for the estimate period.

The adjustments will be determined for the quantities of bituminous products and the average fuel requirements for processing a unit of work as set forth herein.

**COST ADJUSTMENT FACTORS FOR FUEL USAGE**

<u>Item of Work</u>	<u>Units</u> <u>Gasoline</u>	<u>Code</u>	<u>Diesel</u>
Excavation & Embankment (Except Structure and Foundation)	gallons/cubic yard 0.15	(E)	0.29
Granular Materials, Stabilizer Aggregates or Coarse & Seal Aggregates	gallons/cubic yard 0.57 or gallons/ton 0.40	(GY)  (GT)	0.88  0.62
Subgrade & Base Mixing Items	gallons/square yard 0.028	(M)	0.044
Hot Mix Asphalt (HMA)	gallons/ton 0.78	(B)	2.57
Asphalt Drainage Course	gallons/square yard 0.15	(D)	0.49
Portland Cement Concrete Base & Pavement	gallons/square yard 0.15	(C)	0.11
Bridge Items, Structural Concrete, Pipe Culverts, (Including Foundation & Structural Excavation and all other Concrete related items)	gallons/\$1000 13.0	(S)	11.0

**CONSTRUCTION MATERIALS**

The items and quantities subject to compensation adjustment:

**ADJUSTMENT CODE**

- (A1) Asphalt for HMA mixture -- theoretical gallons based on job mix formula and unit weight of 8.43 pounds per gallon (new asphalt only for recycled HMA mixture).
- (A2) Asphalt for Surface Treatment -- pay quantity in gallons.
- (A3) Asphalt for Prime -- pay quantity in gallons.
- (A4) Asphalt for Curing Seal -- 0.25 gallons per square yard.
- (A5) Asphalt for Bituminous Treated Roving -- 0.50 gallons per square yard.
- (A6) Asphalt for Asphalt Drainage Course -- theoretical gallons per square yard based on job mix formula and unit weight of 8.43 pounds per gallon.

Any difference between checked final quantity and the sum of quantities shown on the monthly estimates for any item will be adjusted by the following formula:

$$FA = (FCQ - PRQ) \times EA$$

Where

- FA = Final Adjustment
- FCQ = Final Checked Quantity
- PRQ = Total Quantity Previously Reported on Monthly Estimate
- EA = Total Adjustment Shown on Monthly Estimate

The final adjustment is to consider any error(s) that may have been made in the computations of monthly adjustments.

After the expiration of contract time, including all authorized extensions, adjustments will be computed using fuel and material prices that are in effect at the expiration of contract time.

ADJUSTMENTS

1. Adjustments will be made monthly using quantities shown on the MONTHLY ESTIMATE.
2. No adjustment will be made for price changes less than plus or minus 5%.
3. The adjustment period selected when establishing the Adjusted Base Cost will be the months in which the work was accomplished for the particular item being adjusted. This period will be entered in the Office of State Aid Road Construction's monthly computer estimate, by the Engineer, opposite the appropriate item and submitted to State Aid as part of the estimate.
4. Actual monetary adjustments for each item will be made by multiplying the Price Differential (either plus or minus) by the number of gallons used as determined from quantities of work performed during the pay period.
5. No adjustment will be made for items or work accomplished after expiration of Contract Time.

**S-109.09--Freight Rates and Labor Rates.** No allowance or deduction will be made for increase or decrease in freight rates or demurrage or for any increase or decrease in labor rates unless so stipulated in the special provisions or otherwise provided for.

**S-109.10--Payment of Withheld Funds.** The Contractor may, with the written consent of the Surety, withdraw the whole or any portion of the amount retained by the Board and State Aid Engineer under the provisions of S-109.06.3, by depositing certain securities with the State Treasurer of the State of Mississippi as provided for and in accordance with the provisions of Section 31-5-15 Mississippi Code, 1972, Annotated.

The Contractor shall make written request to the Board and State Aid Engineer for deposit of securities in lieu of retainage. Written consent shall be obtained by the Contractor from the Surety and furnished to the Board and State Aid Engineer prior to making deposit with the State Treasurer.

It will be the responsibility of the Office of State Aid Road Construction to handle the proper exchange of information as to funds being held as retainage, records of deposits, and permissible release of deposit with the State Treasurer in accordance with established procedures.



**S-109.11--Acceptance and Final Payment.** When the Engineer has determined the Contractor has performed all of the work in accordance with the terms of the contract, and that all test reports are on file, he will notify the State Aid Engineer accordingly, requesting that the State Aid Engineer make a final inspection of the work. The State Aid Engineer or his representative shall make such final inspection in company with the Engineer and, if he concurs with the Engineer's recommendation that the work be accepted, the Board and the State Aid Engineer will then formally accept the work in writing and a copy of said letter furnished the Contractor.

Whenever the work provided for in the contract shall have been completely performed on the part of the Contractor and all parts of the work have been approved by the State Aid Engineer and accepted by the Board and State Aid Engineer, a final estimate showing the value of the work will be prepared by the Engineer as soon as the necessary final measurements and computations can be made. The amount of this estimate, less any sums that have been deducted or retained under the provisions of the contract, will be paid to the Contractor as soon as practicable after the final acceptance. The Board and State Aid Engineer may at their discretion withhold final payment until receipt from the Contractor's Surety of a statement consenting to the release of a part of or all of the retainage.

The acceptance by the Contractor of the last payment as aforesaid shall operate as and shall be a release to the County and State from all claims or liabilities under the contract for anything done, furnished or relating to the work under the contract, or for any act or neglect of said County or State relating to or connected with the contract.

**S-109.12--Right to Audit.** The Office of State Aid Road Construction reserves the right to audit the Contractor's records at any time during the contract period and up to three years after the final contract payment or up to three years after any litigation is filed with court, whichever is later. If the Office of State Aid Road Construction commences an audit, the Contractor will be required to provide sufficient original documents and records to satisfy the Office of State Aid Road Construction that the costs included in the Contractor's claim were incurred solely in performance of the referenced project and project phase and were not incurred on any other project or phase of the referenced project that the Contractor is constructing or has constructed. The Office of State Aid Road Construction's audit will be conducted in accordance with United States General Accounting Office's Governmental Auditing Standards, the Institute of Internal Auditor's Professional Practice Standards, and the American Institute of Certified Public Accountant's Auditing Standards.

**S-109.13--Contract Overpayment(s)**. The Contractor is duly responsible to and will immediately reimburse the Office of State Aid Road Construction, without any demand therefor, for any overpayment(s) of which he has knowledge or through due diligence, should have knowledge.

By the execution of the contract, the Contractor also agrees that if the Office of State Aid Road Construction has made any overpayment(s) to the Contractor on any previously executed contract(s), the Office of State Aid Road Construction may notify the Contractor in writing of the nature and the amount of the overpayment(s). If the Contractor fails to remit the overpayment(s) to the Office of State Aid Road Construction within thirty (30) calendar days, the Office of State Aid Road Construction may withhold **any** payment(s) due the Contractor until said overpayment(s) are received.

**S-110.01--Application. Projects Constructed With Federal Funds.**

**S-110.02--Payment of Predetermined Minimum Wages.** Contract provisions are supplemented by the Predetermined Wage Rates attached thereto and made a part thereof. The Contractor and his subcontractors, if any, shall pay not less than those rates which have been predetermined to be those prevailing on the same type of work on similar construction in the immediate locality. The wage rates contained in this decision are straight hourly wage rates.

No laborers or mechanics may be employed on the work except in accordance with the classifications set forth in the schedule mentioned above; provided, however, that in the event additional classifications are desired, application shall be made by the Contractor to the Office of State Aid Road Construction for appropriate classifications and rates, and if there is urgent need for any additional classification of laborers and mechanics to avoid undue delay in the work, the Contractor may employ such laborers and mechanics at rates conformable to similar classifications in the wage decision provided he has made written application to the Office of State Aid Road Construction for a supplemental decision, and provided further that the Contractor will retroactively adjust, upon receipt of the supplemental decision, any wages of laborers or mechanics if the rates predetermined exceed the rates paid by the Contractor.

While the wage rates shown are the minimum rates required by the contract to be paid during its life, this is not a representation that labor can be obtained at these rates. It is the responsibility of bidders to inform themselves as to local labor conditions and prospective changes or adjustments of wage rates. No increase in the contract price shall be allowed or authorized on account of the payment of wage rates in excess of those listed herein. No laborer or mechanic shall be required to work more than forty hours in any work-week unless overtime is compensated at one and one-half times his basic rate.

All mechanics and laborers employed or working upon the site of the work shall be paid unconditionally and not less often than once a week, and without subsequent deduction or rebate on any account, the full amounts due at time of payment computed at wage rates not less than those contained in the schedule except such payroll deductions as are permitted by existing Federal Laws and Regulations, regardless of any contractual relationship which may be alleged to exist between the Contractor or subcontractor and such laborers and mechanics.

The Wage Determination Decision shall be posted by the Contractor, in the prescribed manner, at the site of the work in a prominent place where it can be easily seen by the workers.

The State Aid Engineer may withhold or cause to be withheld from the Contractor so much of the amount due the Contractor as may be considered necessary to insure payment to laborers and mechanics employed by the Contractor or any subcontractor on the work the full amount of wages required by the contract.

The wages of labor shall be paid in legal tender of the United States, except that this condition will be considered satisfied if payment is made by a negotiable check, on a solvent bank, which may be cashed readily by the employee in the local community for the full amount, without discount or collection charges of any kind. Where checks are used for payment, the Contractor shall make all necessary arrangements for them to be cashed and shall give information regarding such arrangements.

No fee of any kind shall be asked or accepted by the Contractor or any of his agents from any person as a condition of employment on the project.

No laborers shall be charged for any tools used in performing their respective duties except for reasonably avoidable loss or damage thereto.

Every employee on the work covered by this contract shall be permitted to lodge, board, and trade where and with whom he elects and neither the Contractor nor his agents, nor his employees shall directly or indirectly require as a condition of employment that an employee lodge, board, or trade at a particular place or with a particular person.

No charge shall be made for any transportation furnished by the Contractor or his agents to any person employed on the work.

#### **S-110.03--Statements and Payrolls.**

1. The Contractor and subcontractors shall submit one copy each of FORMS CAD-880, "Weekly Summary of Wage Rates" and CAD-881, "Weekly Statement of Compliance" each week to the State Aid Engineer and to the County Engineer. If submissions of the here-in-before stated forms are delinquent by (14) fourteen days the State Aid Engineer shall hold progress estimates for payment, until the required completed forms are submitted. Each Contractor and subcontractor shall preserve his weekly payroll records for a period of three years from the date of completion of the contract.
2. The payroll records shall contain the name, address and social security number of each employee, his correct classification, rate of pay, daily and weekly number of hours worked, itemized deductions made and actual wages paid.
3. The Contractor will make his payroll records available at the project site for inspection by the State Aid Engineer or his authorized representative, and will permit such representative to interview employees during working hours on the job.

#### **Sections S-111 thru S-199 - Blank.**

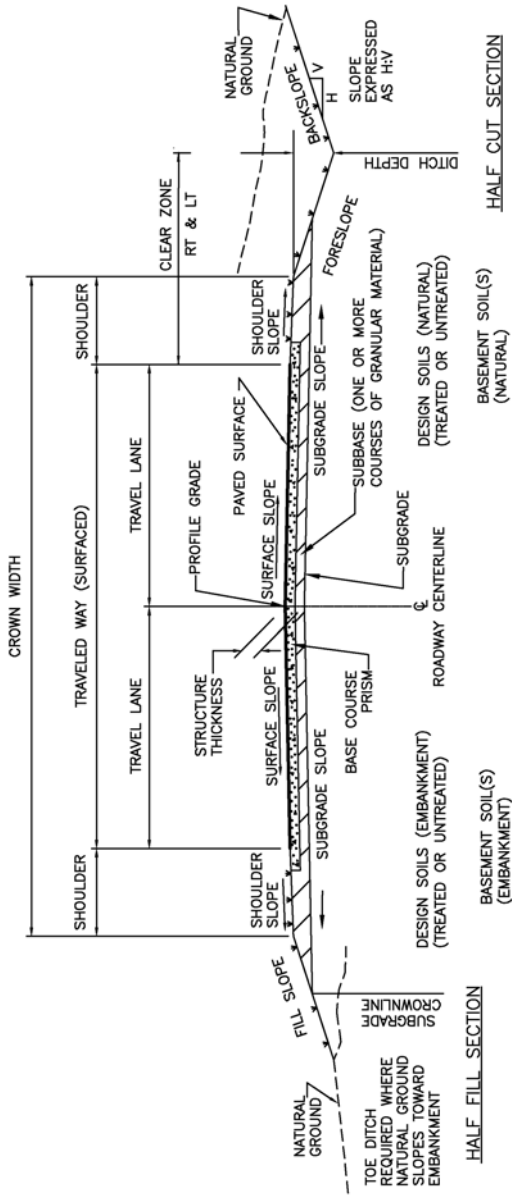

FIGURE — 1. PAVEMENT STRUCTURE  
(To Subgrade Crownline)



<u>Section</u>	<u>Page</u>
S-200 - MOBILIZATION	2-1
S-201 - CLEARING AND GRUBBING	2-2
S-202 - REMOVAL OF STRUCTURES AND OBSTRUCTIONS	2-5
S-203 - EXCAVATION AND EMBANKMENT	2-8
S-204 - Blank	2-21
S-205 - SUBGRADE PREPARATION	2-22
S-206 - STRUCTURE EXCAVATION FOR CULVERTS, BOXES AND MINOR STRUCTURES	2-24
S-207 - Blank	2-26
S-208 - LINEAR GRADING	2-27
S-209 - Blank	2-29
S-210 - ROADSIDE DEVELOPMENT - GENERAL PROVISIONS	2-30
S-211 - TOPSOILING	2-31
S-212 - GROUND PREPARATION AND FERTILIZER	2-35
S-213 - Blank	2-37
S-214 - SEEDING	2-38
S-215 - MULCHING	2-42
S-216 - thru S-225 - Blank	2-44
S-226 - SOLID SODDING	2-45
S-227 - EXCELSIOR BLANKET	2-48
S-228 - Blank	2-49
S-229 - PAVED DITCHES	2-50
S-230 - BITUMINOUS TREATED ROVING	2-52

S-231 - EROSION CONTROL FABRIC	2-54
S-232 - GEOTEXTILE FABRIC STABILIZATION	2-56
S-233 - TEMPORARY SILT FENCE	2-58
S-234 - Blank	2-60
S-235 - TEMPORARY EROSION CHECKS	2-61
S-236 - TEMPORARY SILT BASINS	2-62
S-237 - and S-238 - Blank	2-63
S-239 - TEMPORARY SLOPE DRAINS	2-64
S-240 - GEOGRID REINFORCEMENT OF EMBANKMENT SLOPES AND SUBGRADES	2-66
S-241 - thru S-299 - Blank	2-68



**S-200.01--Description.** Mobilization shall consist of moving all labor, equipment, supplies, and incidentals to the project site and removing same after other work under the contract has been completed. It shall also include all mobilization preconstruction costs which are necessary direct costs to the project and are of a general nature rather than directly attributable to other pay items.

### **COMPENSATION**

#### **S-200.02--Method of Measurement.**

**S-200.02.1--Mobilization.** Measurement for payment will be in accordance with the following schedule:

- (1) When five percent of the original contract amount is earned from other bid items (exclusive of those listed as dependent items), fifty (50) percent of the amount bid for mobilization, or five percent of the original contract amount, whichever is less, will be paid.
- (2) When ten (10) percent of the original contract amount is earned from other bid items (exclusive of those listed as dependent items), one hundred (100) percent of the amount bid for mobilization, or ten (10) percent of the original contract amount, whichever is less, will be paid.
- (3) Upon completion of all work, payment of any amount bid for mobilization in excess of ten (10) percent of the original contract amount will be paid.

In the event the contract is terminated under the provisions of S-108.09, the percentages listed will not be used in computing total payment, but the percentages of original contract amount (exclusive of dependent items) earned at the time of termination will be applied to the lump sum price bid for mobilization.

**S-200.03--Basis of Payment.** Mobilization will be paid for at the contract lump sum price, which shall be full compensation for completing the work specified.

Payment will be made under:

**S-200-A:** Mobilization - lump sum

When not listed as a pay item, the cost of this work shall be included in the prices bid for other items.

**S-201.01--Description.** This work shall consist of clearing, grubbing, removing and disposing of all things within the limits of the right-of-way and easement areas, except things designated to remain or to be removed in accordance with other provisions of the contract. This work shall also include the preservation from injury or defacement of all vegetation, objects, or materials designated to remain or to be salvaged, and the removal and satisfactory disposal of obstructions and salvable material when their removal and disposal is not otherwise provided in the contract. The requirements for removal and disposal shall be in accordance with the provisions and requirements of S-104.05 and S-202.

### **CONSTRUCTION REQUIREMENTS**

**S-201.02--General.** The Engineer will establish right-of-way lines, easement lines, and designate all trees, shrubs, plants, and other items to remain.

It is the intent of these specifications that all desirable natural growth within the right-of-way and easement areas be preserved where practicable, and that all things which detract from the aesthetic value of the completed work, unnecessarily interfere with construction, or would unnecessarily interfere with future maintenance be removed. The Contractor shall be responsible for preserving all things designated to be salvaged or to remain. In areas where desirable natural growth is designated to remain, the Contractor shall thin or trim shrubbery and live trees to the extent consistent with the intent of these specifications. Use of methods or equipment which might mar or destroy vegetation designated for preservation will not be permitted.

All clearing and grubbing necessary for setting construction stakes shall be completed a satisfactory distance ahead of grading operations. Refer to S-107.22.5 for restrictions and protection of the cleared area.

### **S-201.03--Clearing and Grubbing.**

**S-201.03.1--Clearing and Grubbing-Lump Sum Basis.** Surface objects, trees, stumps, roots, and other protruding or underground obstructions, not designated to remain, shall be cleared and grubbed (including mowing, as required). Undisturbed stumps and roots and nonperishable solid objects which will be a minimum of three feet below subgrade or slope of embankment may be left when authorized by the Engineer. When authorized, stumps and nonperishable solid objects in swampy or wooded areas where mowing is not anticipated may be allowed to remain, provided they do not extend more than six inches above the ground line or low water level.

The Engineer may also permit sound stumps to remain outside the construction limits provided they are cut off flush with or below the surface of the final ground line.

Except in areas to be excavated, stump holes and other holes from which obstructions are removed shall be backfilled with suitable material and thoroughly compacted as specified.

All operations shall be conducted in such a manner as to prevent damage to anything that is to remain on the right-of-way or to adjacent property.

Burning of perishable material shall be done only in accordance with applicable laws, ordinances, and regulations. If not burned, materials and debris shall be removed from the right-of-way and disposed of outside the limits of view from any public road or facility. Locations for disposal shall be obtained by the Contractor in accordance with S-104.06.

Low hanging and unsound or unsightly branches on trees or shrubs designated to remain shall be removed as directed. Branches of trees extending over the roadway shall be trimmed to give a clear height of at least twenty (20) feet above the roadway surface. All trimming shall be done by skilled workmen and in accordance with good tree surgery practices. An approved asphaltum base paint prepared specifically for tree surgery shall be furnished and applied by the Contractor to cut or scarred surfaces on trees or shrubs selected to remain.

**S-201.03.2--Clearing and Grubbing-Area Basis.** The scope and method of work shall conform to the provisions and requirements of S-201.03.1, except as specifically provided in Method of Measurement herein below.

**S-201.04--Clearing and Grubbing-Bridge Sites.** When separate and concurrent grading and bridge contracts are to be in progress between the termini of construction, clearing and grubbing of the bridge site (Reference definition in S-101.02) shall be the responsibility of the Grading Contractor, unless the bridge contract contains a pay item for clearing and grubbing.

When a contract is let for bridge construction and there is no coincidental grading contract in existence, clearing and grubbing of the bridge site shall be considered as incidental to and included in the bridge items and no separate payment will be made therefor unless a pay item for clearing and grubbing is indicated in the contract.

Clearing and grubbing of bridge sites shall conform to the requirements of S-201.03.

## COMPENSATION

### S-201.05--Method of Measurement.

**S-201.05.1--Lump Sum Basis.** The area included under this item will be the entire area within the right-of-way lines and easements required to construct slopes according to the typical section shown on the plans. No measurement will be made except when the area of the right-of-way has been increased or decreased from that shown on the plans when bids were received.

In this case, the lump sum contract price will be adjusted in the same ratio that the area of the right-of-way has been increased or decreased.

**S-201.05.2--Area Basis.** The area included under this item will be measured in acres. Measurement will only be made of the area actually cleared and grubbed and will not include areas for which payment is made under another item, or where only grass, weeds, roots, farm crops, and scattered small bushes have been cleared.

Areas acquired for use by the Contractor as haul routes, or areas acquired by the Contractor for his own use will not be measured for payment.

### S-201.06--Basis of Payment.

**S-201.06.1--Lump Sum Basis.** This work will be paid for at the contract lump sum price adjusted when necessary in accordance with the provisions of S-201.05, which price or adjusted price shall be full compensation for the work as specified.

**S-201.06.2--Area Basis.** The work under this item, measured as prescribed above, will be paid for at the contract unit price per acre which shall be full compensation for satisfactorily completing the work as specified.

**S-201.06.3--Exclusion Basis.** When the bid schedule of the contract does not contain an item of Clearing and Grubbing, the necessary work shall be performed in accordance with this section, and will not be paid for directly, but will be considered as a subsidiary obligation of the Contractor under other contract items.

Payment will be made under:

**S-201-A:** Clearing and Grubbing - lump sum

**S-201-B:** Clearing and Grubbing - per acre

**S-202.01--Description.** This work shall consist of the removal and the satisfactory disposal of all buildings, fences, structures, old pavements, abandoned pipe lines, and other obstructions which are not designated to remain or to be removed and disposed of under other provisions of the contract or under separate contracts or agreements (Reference is made to S-104.06). This work shall also consist of necessary excavation incidental to the removal of structures and obstructions and backfilling the resulting cavity.

### **CONSTRUCTION REQUIREMENTS**

**S-202.02--General.** The Contractor shall preserve and protect all structures, fences, public and private utilities, and improvements, above or below the ground, which are to remain or be removed by others as set out in S-104.05. Unless specified, removal or adjustment of these items will not be the responsibility of the Contractor. However, the Contractor shall arrange and conduct his operations to conform to the requirements set out in S-105.06 and S-105.07.

The Contractor shall raze or remove and satisfactorily dispose of all buildings, structures, fences, and other obstructions, except those items indicated to remain or be otherwise removed and disposed of. Basements or cavities left by structure removal shall be filled to the level of the surrounding ground, compacted as directed, or if within the limits of construction, compacted in accordance with S-203.09.3.

All materials not designated for salvage shall be disposed of by the Contractor in accordance with S-201.03 and S-104.06.

Blasting, if permitted, or other operations necessary for the removal of an existing structure or other obstruction which may damage new construction shall be completed prior to constructing the new work. The Contractor shall employ methods for removal to ensure that new work, items in place to remain, or materials to be salvaged will not be damaged (Reference is made to S-107.12).

All material designated for salvage shall be removed, without unnecessary damage, in sections or pieces which may be readily transported and shall be stored by the Contractor at designated sites within the project limits.

**S-202.03--Removal of Bridges, Culverts, and Other Drainage Structures.** Bridges, culverts, and other structures, in use by traffic, shall not be removed until the traffic is satisfactorily accommodated otherwise.

Unless otherwise directed, existing structures shall be removed to at least one foot below the final ground line or designated low water level. The removal of portions of bridges located in navigable streams shall be subject to the requirements set out in the permit of the authority approving the location and plans and authorizing construction of the new structure.

Unless otherwise specified in the proposal, or noted on the plans, structural steel, timber, and salvageable material shall remain the property of the County. Steel or timber bridges shall be carefully dismantled without unnecessary damage. Steel members shall be match marked, and all salvaged material shall be stored as specified in S-202.02.

When required on the plans or in the proposal, concrete which is suitable for riprap shall be salvaged and stockpiled, or otherwise disposed of in accordance with S-202.05.

**S-202.04--Removal of Pipe.** All culvert pipe designated to be salvaged or relaid shall be carefully removed and every reasonable precaution taken to avoid breaking or damaging. Pipes designated to be relaid shall be removed, handled, and stored when necessary so that there will be no loss or damage before relaying. The Contractor shall replace without extra compensation all sections lost from storage or damaged by negligence or improper methods to the extent its reuse is deemed by the Engineer to be unsatisfactory. Pipes not designated to be salvaged or relaid shall be disposed of by the Contractor in accordance with S-201.03.1 and S-104.06.

**S-202.05--Removal of Pavement, Sidewalks, Curbs, Etc.** When required on the plans or in the proposal, concrete pavement, sidewalks, curbs, gutters, etc. designated for salvage shall be broken into pieces not exceeding 150 pounds in weight unless otherwise specified and shall be stockpiled at locations designated by the Engineer within the project limits or at other locations designated in the contract. All excess over that required for salvage, and all when none is required for salvage, shall be disposed of by the Contractor, without regard to size of pieces in accordance with S-201.03.

### **COMPENSATION**

**S-202.06--Method of Measurement.** When the proposal stipulates that payment will be made for removal of obstructions on a lump sum basis, the pay item, Removal of Obstructions, will include all structures and obstructions encountered within the right-of-way and easement areas shown on the plans and removed and disposed of in accordance with the provisions of this Section. Where the proposal stipulates that payment will be made for the removal of specific items on a unit basis, measurement will be made by the units stipulated in the proposal.

When pipe removal is shown in the contract as a separate pay item, the length of pipe removed will be in linear feet, computed by multiplying the number of sections removed by their nominal commercial length.

**S-202.07--Basis of Payment.** Removal of Obstructions, Pay Item No. S-202, will be paid for at the contract lump sum price which shall be full compensation for removing and disposing of the obstructions in accordance with the provisions of the contract.

Specific obstruction items stipulated for removal and disposal under Pay Item Nos. S-202-A, S-202-B, S-202-C and S-202-D, will be paid for at the contract unit price bid per unit specified in the proposal, which shall be full compensation for satisfactorily completing the work specified.

Payment will be made under:

- S-202-A:** Removal of Obstructions - lump sum
- S-202-B:** Removal of \_\_\_\_\_ - per unit  
(Item)
- S-202-C:** Removal of \_\_\_\_\_ - per linear foot  
(Item)
- S-202-D:** Removal of \_\_\_\_\_ - per square yard  
(Item)
- S-202-E:** Removal of Pipe (All Sizes) - per linear foot

**S-203.01--Description.** This work shall consist of excavation and embankment required for the roadway, ditches, channel changes, and borrow material, and includes the preparation of subgrade and foundations, the construction of embankments and other utilization or disposal of materials excavated, and the compaction and dressing of excavated areas and embankments.

**S-203.02--Classifications of Excavation.** Where classification is provided by separate pay items in the proposal, the excavation specified under this section may be classified by any of the following classes:

**S-203.02.1--Unclassified Excavation.** When no pay item is included in the contract for other classes of excavation, unclassified excavation will consist of the excavation and processing or disposal of all materials of whatever character encountered in the work. When pay items are included for other classes of excavation, unclassified excavation will consist of the excavation and processing or disposal of all materials except those for which additional pay items are provided.

**S-203.02.2--Rock Excavation.** When shown as a pay item, rock excavation will consist of material which cannot be excavated without blasting and shall also include boulders and detached stones having a volume of one-half cubic yard or more each. The use of the words "rock," "boulders," or "stone," or synonyms of these words appearing elsewhere in these specifications does not imply that these materials may be included under this classification unless so indicated in the contract.

The Contractor shall immediately notify the Engineer when rock excavation is encountered during the progress of the work so the necessary measurements may be made for determining the volume removed.

**S-203.02.3--Muck Excavation.** When shown as a pay item, muck excavation will consist of the excavation, removal, and disposal of natural deposits of saturated or unsaturated mixtures of soils and organic matter unsuitable for foundation materials. The State Aid Engineer, after consideration of the material and the conditions involved at the time of excavation, will be the sole judge as to whether the material involved will be classified as muck excavation.

**S-203.02.4--Borrow Excavation.** Borrow excavation will consist of approved material required for the construction of embankments or other portions of the work. The Contractor shall make arrangements for obtaining borrow, and shall pay all costs involved. Contractor furnished borrow shall meet the requirements of S-106.02 and S-703.21.



**S-203.02.5--Channel Excavation.** When shown as a pay item, channel excavation will consist of excavation and disposal of all material required for the widening, deepening, or straightening of an existing channel or the construction of a new channel. Material from channel excavation used in the roadbed or other required embankment construction will be classified as unclassified excavation.

**S-203.02.6--Special Excavation.** When shown as a pay item, special excavation will consist of the excavation and disposal of the following: unsuitable materials required to be removed below natural ground under embankments; unsuitable materials encountered in soils not placed under this contract; or excavation below required embankments specified for the salvaging and stockpiling of topsoil and plating material.

**S-203.02.7--Excess Excavation.** When shown as a pay item, excess excavation will consist of excavation which cannot be satisfactorily used or disposed of within the right-of-way. Except for muck excavation, excess excavation may include any type, kind, or class of excavation which the Engineer determines must be removed from the right-of-way. It will not include any excess caused by the Contractor importing too much excavation from sources outside the roadway structure; in this case the excess excavation shall be removed from the right-of-way at the expense of the contractor. (Refer to S-104.07)

When shown as a pay item and unless otherwise indicated in the contract, the Contractor shall provide a disposal area for excess excavation.

**S-203.02.8--Surplus Excavation.** When shown as a pay item, surplus excavation will consist of required excavation within the right-of-way, which is in excess of or unsuitable for that required for embankments and which can be satisfactorily used or disposed of within the right-of-way.

**S-203.02.9--Stripping Excavation.** Stripping excavation shall consist of the excavation, removal and disposal of all overburden materials of whatever character necessary to satisfactorily expose suitable selected material.

**S-203.02.10--Estimated On Site Excavation (E.O.S.E.).** Where projects cannot be balanced from material from within the right-of-way, excavation identified as Estimated On Site Excavation (E.O.S.E.) shall become the property of the contractor. It shall be excavated, used in the embankment if suitable, and paid for as Borrow Excavation (F.M.E.), if used in the embankment.

### CONSTRUCTION REQUIREMENTS

**S-203.03--General.** Excavation and embankment operations may be started at the location and in the sequence approved by the Engineer when:

- (1) sufficient clearing and grubbing has been completed and accepted;
- (2) the work has been cross sectioned and slope staked;
- (3) installation of required pipes, culverts, and approved backfills are complete;
- (4) the site has been prepared in accordance with these specifications;
- (5) the Contractor has informed himself as to the proper haul and disposal of material.

Excavations and embankments shall be finished to reasonably smooth and uniform surfaces. No material shall be wasted without permission of the Engineer. Excavation operations shall be conducted so that material outside the limits of slopes will not be unnecessarily disturbed.

Where plating is contemplated, either in cut or fill sections, appropriate adjustment shall be made in the graded section during construction so that the finished section after plating will conform within allowable tolerances to the typical sections shown on the plans.

Unless otherwise specified, rock larger than three inches shall be removed to a minimum depth of eight inches below subgrade within the limits of the roadbed, and the excavation backfilled with material designated on the plans or approved by the Engineer. Care shall be taken that undrained pockets are not left in the surface of rock. Rock removed more than 12 inches below subgrade will not be measured for payment. The backfilling of this depth in excess of 12 inches will be at the expense of the Contractor.

Borrow material should not be placed until after excavation from the roadway has been placed in embankments. Excess material determined to have been caused by the Contractor importing too much excavation from sources outside the roadway shall be removed from the right-of-way in accordance with S-104.06 unless the Engineer orders that the material be disposed of within the right-of-way. In either case, the volume of excess material will be measured by the method deemed most appropriate by the Engineer under the provisions of S-109.01 and deducted from measured quantities. The Contractor shall not excavate beyond the dimensions and elevations established or approved, and no material shall be moved prior to the staking out and cross-sectioning of the site.

Additional requirements shall be those applicable conditions governing the use of local materials as set out in S-106.

Obliteration of old roadways shall include all operations necessary to incorporate the old roadway into the new roadway or into the surrounding right-of-way in a way that will provide a pleasing appearance from the new roadway. Unless other pay items are provided, roadway obliteration will be paid for as unclassified excavation.

When the Contractor's excavating operations encounter remains of prehistoric dwelling sites or other artifacts of historical or archeological significance, the operations shall be temporarily discontinued. The Engineer will contact appropriate authorities to determine the disposition thereof.

When directed by the Engineer, the Contractor shall excavate the site in a manner to preserve the artifacts encountered, and if required shall remove them for delivery to the custody of the proper State authorities. Such excavation will be considered and paid for as extra work.

Where excavation to grade results in a foundation, subgrade, or slope of unsuitable soil, the Engineer may require the Contractor to remove unsuitable materials and backfill to the required grade with approved material. Slides or other soil failures shall be removed by the Contractor unless their removal is waived by the Engineer. The Contractor shall conduct his operations in such a way that the Engineer can take the necessary cross sections before backfill is placed.

The Engineer may designate as unsuitable those soils which cannot be properly compacted under satisfactory conditions. All unsuitable material shall be disposed of as specified or directed.

When the contract requires, or the Engineer orders, excavation to be handled more than one time prior to final placement (such as topsoil to be stockpiled and reserved for later use), this excavation will be paid for at the contract unit price for the class excavation involved for each handling approved by the Engineer, or will be paid for as another item of work for the final handling when so specified.

**S-203.04--Topsoil.** Where the salvaging and stockpiling of topsoil or plating material is specified, this operation shall be completed before beginning excavation of the underlying material.

**S-203.05--Construction of Bridge Approaches.** The construction of "spill through" embankments and approaches shall be the responsibility of the grading contractor. The existence of a separate contract awarded for bridge construction will not alter this responsibility.

At each approach, the Grading Contractor shall construct and finish as soon as practicable sections of the embankment or approaches extending a minimum of 100 feet from each bridge end.

The allowable tolerance for initial construction of bridge end slopes to be paved will be plus six inches, but all other bridge end slopes shall be finished to the lines and grades specified.

Prior to installation, the Bridge Contractor shall properly shape the area to be covered with slope paving. He shall drive piling through the fill, complete the end bents, end spans, and slope paving as soon as practicable after the bridge end fills have been placed in order that the grading may be completed by the grading contractor. (Reference is made to S-105.07 and S-201.04).

**S-203.06--Excavation Operations.** Excavation operations shall be so conducted as to minimize the loosening of materials outside the required slopes or below the indicated grade. No payment will be made for the removal, disposal, or replacement of material determined to be loosened or undercut through carelessness or negligence on the part of the Contractor. Neither will payment be made for excavation which is used for purposes other than designated.

When practicable, excavation and disposal of the material shall be conducted in such a manner that the most suitable material will be placed in the top courses of embankments. Adequate drainage which will conform to the finished drainage system shall be maintained.

All earth cut slopes shall be dressed to smooth and uniform surfaces to conform to the specified sections. Allowable tolerances for cut slopes shall be plus or minus five-tenths (0.5) foot horizontally at subgrade elevation. On deep cuts, a greater tolerance is allowable but not to exceed an additional three-tenths (0.3) foot horizontally for each ten (10) feet of depth. Allowable vertical tolerances at subgrade elevation shall be plus or minus 0.10 foot in elevation.

Care shall be taken to avoid overshooting in all material which requires blasting. All rock cut slopes shall be left with a reasonably uniform surface and all loose, shattered, or over-hanging rock shall be removed.

**S-203.07--Muck Excavation.** The depth and width of the muck excavation will normally be shown on the plans, and the excavation and subsequent basement soil formation shall be completed as soon as practicable in order to obtain maximum consolidation prior to design soil, subbase, base, and pavement construction. When directed by the Engineer, other unsatisfactory foundation material directly beneath or immediately adjacent to muck shall be removed and its removal and disposal included as muck excavation. Excavation of muck shall begin at one end and proceed ahead of backfilling or embankment operations for the full width and depth shown on the plans or as directed.

Placing of embankment material in the excavated area by backdumping may be permitted when the Engineer determines this method of placement to be satisfactory. In this case, placement shall immediately follow the muck removal, and where deemed desirable, the fill shall be carried forward in a wedge shape carrying as high a surcharge above grade as practicable to afford maximum efficiency in displacing the remaining muck. Otherwise, embankment construction shall be performed in accordance with the provisions of S-203.09.

Pressure developed on the advancing toe of the embankment by in-place or displaced muck shall be relieved by excavating and removing the muck. Stream channels or drainage ditches that may be filled by movement of the muck shall be cleaned out immediately. Displaced materials adjacent to the roadway shall be leveled or disposed of as specified. In any case, the material shall be left in such a manner that it will not present an unsatisfactory appearance, interfere with essential drainage, or prevent proper embankment formation.

The Engineer may permit the Contractor to use explosives in accordance with the provisions of these specifications to liquify the muck sufficiently to be displaced by the advancing embankment. Unless otherwise specified, no extra payment will be allowed for materials and labor necessitated by blasting.

**S-203.08--Disposal of Unsuitable, Surplus, Channel, and Excess Excavation.** All material encountered in excavation within the right-of-way which is unsuitable for use in the work shall be removed and disposed of as specified in the contract or as directed. Unsuitable material shall be understood to be any material, which at the proper moisture content cannot be processed to the required density and stability. Unless otherwise specified, the Contractor shall provide at his own expense the location for the disposal of muck and excess excavation, and shall furnish the Engineer with two signed copies of the release as provided in S-104.06.

Surplus excavation as defined in S-203.02.8 shall be used for uniformly widening embankment, for flattening slopes, or in other places within the right-of-way for the purpose indicated. If there is more surplus excavation than can be effectively used within the right-of-way, the Engineer will reclassify the surplus as excess excavation as defined in S-203.02.7 which shall be disposed of off the right-of-way as provided in the contract, or as extra work.

Unless specified for use in embankments, channel excavation may be used to fill old channels, washes, gullies, or wasted as directed. It shall be spread and leveled or otherwise shaped to blend with the adjacent terrain and shall not obstruct drainage, interfere with the property rights of others, or present an unsatisfactory appearance.

Except for material indicated on the plans and measured for payment under another pay item, the Contractor will be paid for both the unsuitable material ordered excavated and disposed of and the material required for backfill at the respective contract prices.

**S-203.09--Embankment Construction.**

**S-203.09.1--General.** Embankment construction shall consist of: constructing roadway embankments; dikes; placing and compacting of approved material where unsuitable material has been removed; backfilling of structures where not otherwise provided for; and placing and compacting embankment material in holes, pits, or other depressions.

This work shall also consist of preparation of the areas upon which embankments are to be constructed. Only approved materials excavated as provided in the contract shall be placed in embankments and backfills; unsuitable or perishable materials such as rubbish, sod, brush, roots, loose stumps, logs, heavy vegetation, sawdust, etc. shall not be incorporated in embankments. Rocks, broken concrete, or other solid material shall not be placed in embankment areas where piles are to be driven.

Special materials for embankments such as for inundated areas, filter beds, etc. or special backfill material may be specified elsewhere in the contract.

**S-203.09.2--Preparation of Embankment Areas.** Preparation of embankment areas shall be in accordance with one or a combination of the following procedures:

**S-203.09.2.1.** All grade points shall be undercut, back-filled with suitable excavation material, and compacted to the density for the design soil portion of embankments. The material excavated from the undercut, if suitable, shall be used in other portions of the work. The undercut at each grade point shall be approximately three feet below the subgrade in the embankment. The undercut shall be extended a sufficient distance into the cut to provide an undercut grade at the point of intersection with the subgrade of not less than three feet below natural ground. Approved undercut will be measured for payment as excavation.

**S-203.09.2.2.** Where a compacted old road surface containing granular materials or surface treatment is within three feet below subgrade, the old road surface shall be scarified as directed. The loosened material shall be compacted to the density specified (SV) for the design soil portion of the embankment prior to placing additional material.

**S-203.09.2.3.** Unless otherwise specified or directed by the Engineer, where the height of an embankment to subgrade will be three feet or less, all sod, vegetable matter, and unsuitable soil shall be removed from the surface upon which the embankment is to be constructed. The cleared surface shall be completely broken up by plowing, scarifying, or disk-harrowing to a depth of at least six inches. The loosened material shall then be compacted to the density specified (SV) for the design soil portion of the embankment.

The removed vegetation and unsuitable soil shall be disposed of as directed. No measurement for payment for removal will be made unless the Engineer requires that the material be loaded and hauled for use or disposal in another area. In this case, measurement for payment will be made as provided in S-203.12.

No direct payment will be made for plowing, scarifying, or disk-harrowing under this type of preparation.

**S-203.09.2.4.** In areas where the height of embankment to subgrade is to be greater than three feet, all material determined by the Engineer to be unsuitable for foundation for the embankment shall be undercut and disposed of as directed. All sod on all other areas shall be thoroughly disk-harrowed before construction of the embankment. Approved undercut will be measured for payment as excavation. No direct payment will be made for disk-harrowing under this type of preparation.

**S-203.09.2.5.** Where embankment is to be constructed on hillsides or against existing roadway slopes, slopes which are steeper than 4:1 shall be continuously benched as the new work is brought up against the slope. Benching shall be of sufficient width to permit operation of placing and compacting equipment. Each horizontal cut shall begin at the intersection of the original ground or slope and the vertical sides of the previous cut. Material thus cut out shall be recompacted along with the new embankment material and will not be measured for payment.

**S-203.09.3--Embankment Formation.** After the area has been prepared as specified, the embankment shall be constructed in full width layers parallel to the finished grade.

Except as herein provided, each layer shall not exceed eight inches (loose) in thickness, and shall be spread, shaped, and compacted so that the completed embankment will conform to the required density, stability, line, grade, and cross-section.

The required stability in embankment construction shall be that which the Engineer determines can be reasonably obtained at the proper moisture content for the material being placed. Sponginess, shoving, or other displacement under heavy equipment will be considered prima facie evidence of lack of stability under this requirement.

Direct casting or similar methods will not be permitted unless authorized in writing by the Engineer. Should direct casting be authorized, all cast material shall be moved from the point where it is deposited, spread and compacted in uniform layers as specified herein.

**S-203.09.3.1--Basement Soils** . In low, swampy ground which will not support the weight of hauling equipment, the Engineer may permit the bottom portion of the embankment to be constructed in a uniformly distributed layer of sufficient thickness to support equipment placing subsequent layers. However, this method will not be permitted in any portion of the fill less than three feet below subgrade. (Reference Figure 1. S-100).

In areas where the embankment material is of a highly varying character, construction shall be performed so as to eliminate pockets or strata of varying materials. Each layer shall be disk-harrowed and heavily bladed for its full depth; or moved from its position of deposit by motor grader, bulldozer, or other equipment; or processed by other means to the extent necessary to eliminate pockets or strata of material of varying character. The layer shall then be shaped and compacted in accordance with these specifications.

Rock in embankment shall be distributed over the area to avoid bridging, nests, or pockets, and all interstices shall be completely filled with earth or stone fragments and compacted. Where only occasional boulders are encountered, they shall be placed near the outer slopes in lower portions of the embankment.

Where the excavated material consists predominately of rock fragments of sizes that cannot be placed in layers of the thickness specified without crushing, pulverizing, or further breaking down of pieces resulting from excavation methods, the material may be placed in layers not exceeding the thickness of the approximate average size of the rocks. The balance of the embankment shall be composed of suitable material placed in layers not exceeding eight inches in loose thickness and compacted as specified.

**S-203.09.3.2--Design Soils**. Each layer of the design soil shall be disk-harrowed and heavily bladed for its full depth, or processed by other approved means to the extent necessary to provide a layer of material reasonably uniform in character. Each layer shall then be shaped and compacted in accordance with these specifications. (Reference Figure 1. S-100).



**S-203.09.3.3--Backfill and Embankment Formation Adjacent to Structures.**

Backfilling around structures shall not start until the structure has been properly cured for the minimum number of days required and permission has been granted by the Engineer to proceed with the work. The work shall be performed only under the direct supervision of the Engineer or his designated representative.

Material used shall be suitable material obtained from structure excavation or from roadway and drainage excavation or other designated material. The material shall be approved before placement, and shall be the best available from the sources. It shall preferably be nonplastic, sandy, or loamy earth and shall be free from large lumps, clods, rock, or other objectionable matter. Adequate provision shall be made for thorough drainage of all backfilling.

The backfill material shall be deposited in uniform, parallel layers on the sides of box bridges or culverts, or other structures. Each layer shall be disk-harrowed and bladed for its full depth or processed by other approved means to the extent necessary to provide a layer of material reasonably uniform in character, and shall be so placed and compacted that drainage of the layer will be away from both the longitudinal and the transverse axes of the structure. In addition, the backfill for abutments, retaining walls, wing walls, or other structures or sections thereof shall be built in layers with each layer being constructed for the full length of the unit and special precaution shall be taken to prevent any wedging action against the structure.

The material for each layer shall be uniformly compacted, preferably by approved mechanical equipment including self-powered mechanical tampers, to not less than the density required in the adjacent embankment. The work shall be conducted so as to form a berm of compacted soil of sufficient width on each side of the structure such that the berms at the top of the structure shall be at least six feet in width. The slopes of the backfill shall not be steeper than 2:1 at any point. Unless otherwise specified, backfilling shall continue to the level of the original ground, to an elevation at least one foot above the top of the structure, or to the top of the graded section, as applicable.

The work shall be conducted in a manner so that the Engineer can make the necessary tests for compaction as the work progresses.

The Contractor shall repair, restore with new work, or make good without extra compensation all damage done to the structure as a result of the backfilling operations.

Payment for this construction is included in the contract unit price for the material with which backfill is made.

**S-203.09.4--Compaction of Embankments.** All embankment material shall be at the moisture content determined to be proper for the particular material being placed so that the resulting work will be both dense and stable.

It shall be the Contractor's responsibility to maintain the proper moisture content during compaction operations, and the Engineer may require moistening or drying as necessary, without additional compensation to the Contractor.

The material shall be compacted until the required density, determined in accordance with S-700.03 and S-700.04 has been attained and the embankment is stable.

Acceptance of compaction will be on a lot basis. A lot size will be based on the Contractor's hourly production rate as set out in State Aid's SOP.

For basement and design soils, the required density shall be 95.0 percent and 98.0 percent, respectively. If a density test fails within minus two percent (-2.0%), 93.0 to 95.0% or 96.0 to 98.0%, of the required density, a verification test will be performed and the average of the two tests will be the test value for the lot. If this test value does not meet the required density (95.0 or 98.0%), the lot shall be rejected. If the original test value exceeds minus two percent (-2%) of the required density, no verification test will be performed and the lot shall be rejected.

Acceptance of compaction for structural backfill will be considered a separate frame of work. The backfill at each structure up to a depth of five feet will be considered a lot. For long structures, the Engineer may specify that the backfill be divided into smaller lots. Each lot will be divided into four approximately equal sublots with two density tests taken at random on each side of the structure. The single test and the lot average shall conform to the required densities set forth above for basement soils or design soils as applicable.

The Contractor shall make allowance for shrinkage and compaction in the construction of embankment.

**S-203.09.5--Tolerances.** The tolerances shown below as allowable shall not prevent the work from meeting the requirements of S-105.03. The allowable vertical tolerance at subgrade elevation shall be plus or minus one-tenth foot in elevation.

The allowable horizontal tolerance at subgrade elevation will be five-tenths of a foot. The allowable tolerance from staked slopes on fills will be plus or minus five-tenths foot horizontally for each 10 feet of fill height except where surplus excavation is required or permitted by the Engineer to be used for uniformly widening embankments or flattening slopes. In these cases tolerances will be modified accordingly.

**S-203.10--Settlement by Blasting.** The procedures for formation and enforced subsidence of embankment through muck areas by blasting will be designated elsewhere in the contract when such methods are required.

**S-203.11--Maintenance of Earthwork.** The Contractor shall satisfactorily maintain all portions of the work until the completion and acceptance of the contract. (Reference is made to S-105.14, S-105.15, and S-105.16). The Contractor shall replace, restore, or reconstruct without extra compensation all portions, including materials, determined by the Engineer to have been displaced or damaged due to carelessness or negligence on the Contractor's part. Carelessness or negligence may include but not be limited to inadequate drainage; failure to remove forms or obstructions; failure to properly prosecute and complete work within the time specified in the contract; neglecting to establish erosion control items; failing to provide continuous maintenance as required under S-105.14; or other avoidable causes for displacement or damages.

If the Engineer determines that the work has been properly prosecuted, constructed, protected, and maintained and earthwork damage is caused by the action of the elements, the Contractor may be paid at the contract unit prices for excavation material, if applicable, required in making repairs.

### **COMPENSATION**

**S-203.12--Method of Measurement.** Items of excavation listed in the proposal will, unless otherwise stipulated, be measured as follows:

**S-203.12.1--Final Measurement (FM).** Whenever this method of measurement is used, the excavation will be measured in its original position and the material actually removed, as ordered as hereinbefore prescribed, shall be computed by the method of average end areas of the sections by plotting or superimposing the final cross-section elevations and measurements onto the original plan cross-sections.

**S-203.12.2--Plan Measurement (PM).** Whenever this method of measurement is used, cross-section templates, reflecting the grades, slopes and sections shown in the original plans, will be plotted or superimposed onto the original plan cross-sections. The excavation volume delineated by these cross-section templates will then be computed by the method of average end areas. If the excavation and embankment work can be completed according to the grades, slopes and sections shown on the original plans, then the quantity computed as set out above and shown on the original plans will be the measurement for final payment.

If, during construction, however, the Engineer finds it necessary to change the grades, slopes and sections to effect a balancing of excavation and embankment quantities, or if such changes are ordered for any other reasons, cross-section templates reflecting the revised grades, slopes and sections will likewise be plotted or superimposed onto the original plan cross-sections. The excavation volume, delineated by these revised sections, will then be computed by the method of average end areas and the revised quantities so computed and reflecting any increased or decreased volume will be the measurement for final payment.

The Engineer reserves the right to measure the completed work, in whole or in part, by Final Measurement (FM) in which case the Final Measurement method shall govern.

Plan Measurement (PM) shall not be used for channel changes, bridge abutments or other isolated areas of excavation.

**S-203.12.3--Loose Vehicle Measurement (LVM).** Whenever this method of measurement is specified, the excavation will be measured in the hauling vehicle at the point of deposit, in accordance with S-109.

**S-203.12.4--Muck Excavation.** Measurement for muck excavation will be made as for other excavation when practicable. When ordinary methods of measurement are not practicable, the volume of muck excavation shall be the actual volume of the prism of earth required to construct the embankment up to an elevation coincident and parallel to the original ground line of the muck area, as determined by borings during the construction or after completion of the embankment.

**S-203.12.5--Rock Excavation.** When the contract contains an item of rock excavation, the Contractor shall immediately notify the Engineer when rock excavation, as defined, is encountered during the progress of the work, so that the necessary measurement may be made for determining the volume removed.

**S-203.12.6--Undercut.** Undercut required by the Engineer prior to replacement of embankment material that is unsuitable for placement in outer portions of embankment slopes will be measured by the cubic yard (FM).

**S-203.12.7--Final Measurement-Embankment (F.M.E.).** Required embankment constructed of Borrow Excavation (F.M.E.), properly constructed, maintained and accepted, will be measured in its final position by the cubic yard, average end area method, within allowable tolerances, complete-in-place. Subsidence if it occurs will not be measured for payment.

**S-203.13--Basis of Payment.** Items in this section, measured in accordance with S-203.12, will be paid for at the contract unit price per cubic yard, which shall be full compensation for completing the work as specified except that payment for Contractor Furnished Borrow material will also include additional requirements as specified in S-106.02.2.

Payment will be made under:

**S-203-A:** Unclassified Excavation ( \_\_\_\_\_ ) - per cubic yard  
PM, FM or LVM

**S-203-B:** Rock Excavation ( \_\_\_\_\_ ) - per cubic yard  
FM or LVM

**S-203-C:** Blank

**S-203-D:** Muck Excavation (FM) - per cubic yard

**S-203-E:** Borrow Excavation (Contractor Furnished  
LVM, Class \_\_\_\_\_) - per cubic yard

**S-203-E1:** Borrow Excavation (F.M.E.)  
(Contractor Furnished) (Class \_\_\_\_\_) - per cubic yard

**S-203-F:** Channel Excavation ( \_\_\_\_\_ ) - per cubic yard  
FM or LVM

**S-203-G:** Special Excavation ( \_\_\_\_\_ ) - per cubic yard  
FM or LVM

**S-203-H:** Excess Excavation ( \_\_\_\_\_ ) - per cubic yard  
FM or LVM

**S-203-I:** Surplus Excavation ( \_\_\_\_\_ ) - per cubic yard  
FM or LVM

**S-203-J:** Stripping Excavation (FM) - per cubic yard

**Section S-204 - Blank.**

**S-205.01--Description.** The subgrade is designated as that part of the roadbed consisting of the design soils upon which the base structure or a surface course is to be placed and its finished construction shall conform to the provisions herein and such special preparation as may be required for the particular base structure or surface course to be constructed. The subgrade preparation shall consist of the construction and compaction of the subgrade in accordance with these specifications.

**S-205.02--Subgrade Preparation.** The subgrade shall be constructed as indicated above in accordance with S-700.04.3 and with the lines, grades and typical section for the particular type of base structure, or surface course as shown on the plans or established by the Engineer. No base structure, or surface course shall be placed on the subgrade until same has been checked and approved by the Engineer.

The subgrade material shall be moistened or dried to the optimum moisture content as determined by AASHTO T-99, Method C, as modified by Mississippi Test MT-8.

The specified value (SV) for subgrade density shall be ninety-eight (98) percent. A unit of deviation will be one percentage point. Field density determinations will be made in accordance with AASHTO T-191, as modified by Mississippi Test MT-10 or MT-16.

All soft and yielding or other unsuitable material which will not compact readily shall be removed and disposed of as directed. No compaction will be required on the material wasted and spread outside the roadway prism as indicated by the typical section. Any unclassified excavation removed will be measured and paid for under the excavation pay item contained in the proposal.

All loose rock or boulders found in the subgrade shall be removed or broken off to a depth of not less than eight (8) inches below the elevation of the subgrade.

The volume of such unsuitable materials described above shall be replaced with approved material and the entire subgrade brought to lines, grades and uniform compaction. Such backfill material will be measured and paid for under the pay item shown for the type material used.

Where practicable the prepared subgrade shall be maintained for a distance equal to an average day's run ahead of the placing of the subbase, base, surfacing or paving materials thereon and the distance shall be not less than five hundred (500) feet in any case. Materials shall not be deposited thereon until the subgrade has been checked and approved by the Engineer.

**S-205.03--Protection of Subgrade.** After the subgrade has been prepared, as specified above, it shall be maintained in a smooth and compacted condition free from ruts and depressions and shall be adequately drained. In handling of materials and the operation of tools and equipment, the Contractor shall protect the subgrade from damage. If damage occurs, the subgrade shall be reshaped, recompact and maintained reasonably close to line and grade until the base, surfacing or pavement is placed.

Specific reference is made to S-107.17 of these specifications.

### **COMPENSATION**

**S-205.04--Basis of Payment.** Subgrade preparation will not be paid for directly, but is designated a necessary part of the construction and the contract unit price for the material going into the subgrade shall be full compensation for subgrade preparation. However, compensation for the removal of soft, yielding or other unsuitable material in the subgrade will be made on the basis of the unit price bid for the excavation item(s) contained in the contract, which price shall be full compensation for excavating, loading, spreading, compacting as required, for all labor, tools, and incidentals necessary to complete the work.

STATE AID **SECTION S-206 - STRUCTURE EXCAVATION FOR** STATE AID 2004  
**CULVERTS, BOXES AND MINOR STRUCTURES**

**S-206.01--Description.** This work shall consist of the removal of all material necessary for the construction of foundations for box culverts, box bridges, pipe culverts and headwalls, and other minor structures when authorized by the section covering their construction. It shall also cover all necessary pumping, bailing, drainage, cribbing, or sheeting; other foundation work; and the backfilling and proper disposal of all excavated material as directed. Unless otherwise specified, excavation for pipe used as sidedrains, underdrains, manholes, inlets and catch basins will not be included in this item.

**S-206.02--Construction Methods.**

**S-206.02.1--Excavation.** No excavation shall be made until the Engineer has cross-sectioned and staked out the work. The Contractor shall exercise care to ensure that the adjacent natural ground is not unnecessarily disturbed or the foundation loosened below the bottom of the footing unless additional excavation is required.

When the plans indicate or the Engineer directs removal of material classified in the contract as muck excavation or special excavation under and adjacent to the location of the structure, the undercut shall be made and the area backfilled and compacted to the required density for approximately one foot above the flow line of the structure before structure excavation is performed.

Foundation areas shall be excavated to the footing elevations and dimensions shown on the plans or as established. The right is reserved to make adjustments in the location or flow line and to make changes in the dimensions of the footings that may be necessary to obtain a satisfactory foundation or to provide adequate drainage.

In addition to the requirements of this subsection, excavation for pipe culverts will be performed in accordance with S-603.03 and S-603.04.

Material encountered which is unsuitable for a stable foundation shall be excavated and backfilled as provided in S-203.03.

Special methods of strengthening the foundation such as gravel, piles, timber, etc. shall be used when directed and will be paid for in accordance with the provisions of S-206.04.



**S-206.02.2--Backfill.** When the plans indicate or the Engineer orders removal of unsuitable material or other undercut below the normal grade line to provide a satisfactory foundation and further orders a specified depth of select material that may not be available from within the right-of-way or easement areas, the Contractor shall furnish a suitable backfill material such as sand, gravel, or other similar granular materials.

### COMPENSATION

**S-206.03--Method of Measurement.** Structure excavation acceptably performed will be measured as follows:

For structures other than pipe culverts, the area to be included in the measurement of structure excavation will be that area bounded by vertical planes one foot outside of the neat lines of the footing.

For pipe culverts, the vertical planes will be one foot each side of the nominal inside diameter of the pipe. The length to be allowed will be one foot beyond each end of the pipe, except when the pipe is joined to another structure for which payment for structure excavation will be made. In this case, the length will be limited to the point of intersection of the centerline of the pipe with the boundary of structure excavation of joining structures.

The depth allowed will be that actually removed between the natural ground line or the bottom of the graded section (whichever is lower) and the bottom of the footing or the bottom of the trench in the case of underdrains. Measurement will not be made for excavation beyond the neat lines described which the Contractor finds convenient or necessary for his particular operation.

In case the Engineer orders additional excavation made for foundation improvement below the depth indicated herein, this excavation within the neat lines designated herein will be included in structure excavation. Backfill of additional excavation shall be performed as for other backfill adjacent to structures and the cost thereof absorbed in other items of work, unless the Engineer orders special materials for foundation improvement. Special materials, if required for backfill, will be included in measured quantities of the materials used.

The volume of structure excavation will be the summations of the products of widths, depths and lengths described.

Unless otherwise specified, selected backfill material shown on the plans or directed by the Engineer to be produced from an area to be excavated under one of the classes of excavation set out under S-203 will be measured and paid for under the applicable item of excavation. Other materials shown on the plans or ordered and used as backfill material will be included in measured quantities of the materials used.

No measurement will be made for water or other liquids removed.

**S-206.04--Basis of Payment.** This item will be paid for at the contract unit price bid per cubic yard, which price shall be full compensation for such excavation, the formation and compaction of backfill, disposal of surplus material and for all materials, equipment, tools, labor and incidentals necessary to complete the work.

Special methods for strengthening the foundation will be measured and paid for at the contract unit prices for the appropriate items contained in the contract for such material used or if no such unit prices are included in the contract, such work will be paid for as Extra Work as provided in S-104.03.

Payment will be made under:

**S-206-A:** Structure Excavation - per cubic yard

**Section S-207 - Blank.**

**S-208.01--Description.** This work shall consist of grading sections of roadway where, in general, the elevation of the existing ground surface or roadbed is practically parallel with the proposed grade line and the bulk of such excavation made will make the necessary embankment construction and can be moved by motor patrols, bull-dozers or other similar equipment to its final position on the adjacent roadway.

The portions of road on which this type of work is proposed will be shown on the plans as Linear Grading and ordinarily no portion will be less than three consecutive one hundred (100) foot stations in length.

Compaction shall be obtained in accordance with the provisions of S-203, Excavation and Embankment.

### **CONSTRUCTION REQUIREMENTS**

#### **S-208.02--Construction Details.**

##### **S-208.02.1--Types of Linear Grading.**

**S-208.02.1.1--Light Linear Grading.** Light linear grading shall consist of pulling ditches, shaping foreslopes and machining the roadbed on a previously constructed road where only a small amount of machining is required to produce a finished section. Unless specifically shown on the plans machining of backslopes will not be required.

**S-208.02.1.2--Heavy Linear Grading.** Heavy linear grading shall consist of grading of such character that, in general, the excavation from backslopes, ditches and roadbed will be sufficient to construct the roadbed to the required lines, grades and cross-section.

**S-208.02.1.3--Linear Grading Special.** Linear grading special shall consist of mowing when necessary and grading ditches at locations noted on the plans. The material, from the grading operation, will be used to dress shoulders and foreslopes. It will not be necessary to dress back slopes unless noted on plans.

**S-208.02.2--General Requirements.** Clearing and grubbing, when required, shall be done only within the grading construction limits plus the addition of any necessary clearing for sight distance. When no pay item for clearing and grubbing is shown, it will be included in the contract unit price bid for Linear Grading.

After the completion of the clearing and grubbing, removal of heavy sod and vegetable matter, the construction shall proceed. Such loosening as is necessary shall be done by plowing or scarifying preparatory to moving the excavation.

The finished section, constructed as shown on the typical section, shall be maintained and preserved by machining. The ditches shall be reasonably close to line and grade and completely drained.

Compaction will be accomplished as specified in S-203.09.4.

**S-208.02.3--Disposal of Material.** Where linear grading is performed and the yield from pulling ditches, shaping backslopes or roadbed is in excess of the material necessary for the construction of the adjacent embankment and cannot be economically moved into its final position with a motor patrol or bulldozer or if necessary to obtain embankment material from other sources to complete the incidental grading corrections, such materials shall be classed as Unclassified Excavation (Special) (LVM) and shall be hauled to their designated final position, or disposal made as ordered by the Engineer.

### **COMPENSATION**

**S-208.03--Method of Measurement.** Accepted linear grading will be measured per one hundred (100) foot station as specified in the proposal.

Measurement of all accepted Light and Heavy Linear Grading will be made along the centerline of the road in one hundred (100) foot stations and fractions thereof, as the case may be.

Linear Grading Special, being used on surface treatment and overlay projects, will be measured by the linear foot on graded sections as set out on the plans or directed by the Engineer.

Unclassified Excavation (Special) (LVM) will be measured as specified in S-203.12.

**S-208.04--Basis of Payment.** Linear grading, measured as provided above, will be paid for at the contract unit price bid per one hundred (100) foot station for:

**S-208.04.1--Light Linear Grading** which will be payment in full for plowing, scarifying, pulling ditches, shaping, and compacting the roadway to the lines and grades shown in the plans.

**S-208.04.2--Heavy Linear Grading** which shall be payment in full for plowing, scarifying, trimming backslopes, pulling ditches, moving excavation along the roadway, compacting and shaping the roadbed to the lines and grades shown in the plans.

**S-208.04.3**--Linear Grading Special which will be payment in full for mowing, grading ditches, spreading, shaping and compacting as shown on the plans or directed by the Engineer.

In either case the contract unit price bid will be full compensation for all equipment, tools, labor and incidentals necessary to complete the work.

**S-208.04.4**-- Unclassified Excavation (Special) measured as specified above will be paid for at the contract unit price bid; which price shall be full compensation for loading and placing all material and for all equipment, tools, labor and incidentals necessary to complete the work.

Payment will be made under:

- S-208-A:** Light Linear Grading - per station
- S-208-B:** Heavy Linear Grading - per station
- S-208-C:** Linear Grading Special - per linear foot
- S-208-D:** Unclassified Excavation (Special) (LVM) - per cubic yard

**Section S-209 - Blank.**

## **SECTION S-210 - ROADSIDE DEVELOPMENT - GENERAL PROVISIONS**

Where the term "plant establishment" is used, it shall be understood to mean the work and time necessary to provide fully established, healthy vegetation.

Where the term "dormant" is used, it shall be understood to mean the temporary inactive stage of a living plant or seed. When the term "dormant season" is used, it shall be understood to mean a period of time during the year when germination and growth is not expected.

Areas on which planting, plant establishment, and maintenance have been performed in accordance with the requirements of the contract, the requirements for growth and coverage for each kind of plant which is in its dormant season may be waived provided at least one of the kind of the plantings which is not in its dormant season shows satisfactory growth and coverage.

When contract time has expired and all work under the contract has been completed except for the specified growth and coverage of vegetative items, liquidated damages will not be charged provided the Engineer's diary documents that all the following conditions have been met:

1. The Contractor has performed all plant establishment work that soil and weather conditions would permit;
2. The Contractor has complied with all instructions of the Engineer with regard to maintenance of the work and plant establishment, including but not limited to watering, replanting, mowing, and other work specified for plant establishment; and
3. The entire work is deemed to be in a satisfactory state of maintenance, or every reasonable effort is being made to provide satisfactory maintenance.

**S-211.01--Description.** This work shall consist of furnishing if specified, excavating, stockpiling if necessary, transporting, spreading, compacting, and finishing topsoil as specified or directed.

### **MATERIALS**

**S-211.02--Material Requirements.** The sources and provisions for use of topsoil from local pits located outside the right-of-way shall be as set forth in S-106. Topsoil furnished by the Contractor shall meet the applicable requirements of S-715.01.3.

When indicated in the contract, topsoil shall be salvaged from within the construction limits. The topsoil shall be removed only from areas and to depths designated by the Engineer.

**S-211.02.1--Materials Specified to be Obtained from the Right-of-Way.** Areas from which topsoil is to be obtained shall be mowed and cleared of foreign materials to the satisfaction of the Engineer.

The approved area shall be excavated neither deeper than the limits of good topsoil nor than necessary to produce sufficient volume to cover the designated areas.

If strata or seams of unsuitable material are encountered during the excavation of topsoil, the material shall be removed from the topsoil. If considered necessary, the area shall be abandoned and satisfactory material produced from other sources.

Topsoil shall either be transported and stockpiled on well drained areas approved by the Engineer, or transported, deposited, and processed directly on designated areas which have been finished, prepared, and approved to receive the topsoil. The Contractor shall spread or dispose of, as directed, all surplus material left in stockpiles without cost to the project.

**S-211.02.2--Materials to be obtained from Sources Outside the Right-of-Way.** Before mining the material, approved areas shall be mowed and raked and cleared of foreign materials to the satisfaction of the Engineer.

Approval of a pit will, in general, constitute acceptance of the material as meeting the requirements of the specifications, provided:

1. Mining of the material is confined to horizontal and vertical limits specified, and the mining is performed in an approved manner.

2. When previously approved excavation limits or mining methods result in the production of unsatisfactory material, mining shall be halted until corrective measures are taken to assure production of satisfactory material.
3. The inability to maintain a normal, approved mining operation in a given pit will be cause for abandonment of that pit.

It is intended that approved mining operations shall include the mixing or blending of materials that will insure a homogeneous mixture complying with the requirements of the contract.

For pits proposed by the Contractor, the Contractor shall obtain and submit for testing representative samples taken at places designated by and witnessed by the Engineer or his representative. If deemed advisable, the Engineer may take the samples, and the Contractor shall furnish the assistance required. Based on test results, the Engineer will approve lateral and depth limits of satisfactory materials.

The Engineer may, at his discretion, sample the material at any point prior to spreading on the road. This sampling and testing will be for the purpose of determining whether or not corrective measures should be taken.

Material produced and approved as provided herein, will be accepted as meeting all requirements at the point of final loading for delivery and incorporation into the work.

Approved topsoil, mined as prescribed, shall be transported and deposited and processed directly into its final position on designated areas which have been finished, prepared, and approved unless temporary stockpiling is required or permitted by the Engineer. In case stockpiling is required or permitted, the Contractor shall spread or dispose of, as directed, surplus material left in the stockpile without cost to the project.

### **CONSTRUCTION REQUIREMENTS**

#### **S-211.03--Construction Requirements.**

**S-211.03.1--Conditioning of Areas to be Plated.** The conditioning of areas to be plated will depend on the type of existing soil on cut slopes or fill slopes. Conditioning shall be performed so as to secure a bond between the existing soil and the topsoil. Unless otherwise directed, the area to be plated shall be shaped and dressed to the required line, grade, and typical section; disk-harrowed to a depth of at least two inches; and be reasonably free of large clods and stones (exceeding three inches in diameter) and other foreign materials before topsoil is deposited.



On non-tillable slopes, the areas shall be shaped and dressed to the required section, and the Contractor shall cut trenches or furrows approximately six inches deep and approximately 24 to 36 inches apart, as directed by the Engineer dependent upon the steepness of the slope, and on approximate contours. Surplus material from trenching shall be uniformly spread over the area to be plated or otherwise disposed of in a satisfactory manner. In no case shall topsoil be placed on slopes until conditioning of the areas has been approved.

**S-211.03.2--Application.** It is intended that the application of topsoil, the application and incorporation of fertilizer, and other erosion control work will constitute continuous construction, and the Contractor shall so organize his overall operation accordingly. When the Engineer has determined that the Contractor has made suitable arrangements to carry out these operations as indicated, topsoil shall be deposited on approved areas and spread to the required depth and section. When the required depth of plating material exceeds eight inches, it shall be placed in two or more approximately equal layers of no more than eight inches each.

Objectionable foreign material, large clods that cannot be broken down, and oversize stones shall be removed and the area dressed to present a uniform appearance.

**S-211.03.3--Compaction.** After spreading and shaping of the topsoil, compaction shall be performed to the degree that will provide a firm layer having a density of at least what might be expected from one complete coverage of a crawler type tractor track while the material is at a satisfactory moisture content.

**S-211.03.4--Compacted Depth of Topsoil.** Topsoil shall be deposited and spread in sufficient quantity so that when compacted it will have the depth specified in the contract.

Determination of depth will be made at random and recorded following compaction of each plated area (lot) of approximately 20,000 square feet and more often if determined by the Engineer to be necessary to control the specified depth. The depth of each lot checked will be the average of at least two and not more than four measurements taken within a square yard area. Except as provided in the following two paragraphs, the average depth of each lot shall not vary from the specified depth by more than one inch or twenty-five (25) percent of the specified depth, whichever is larger. The average depth of the entire area topsoiled (the average of the depths of individual lots) shall not vary from the specified depth by more than one inch.

Topsoil measured and paid for on a cubic yard basis may exceed the stated plus tolerances, provided the finished surface is uniform, does not obstruct drainage, and otherwise meets the approval of the Engineer.

Topsoil specified to be measured and paid for on a square yard basis may exceed the stated plus tolerance and remain in place provided the finished surface is uniform, does not obstruct drainage, and otherwise meets the approval of the Engineer. No additional payment will be made for the excessive material placed. The removal of excessive topsoil shall be at the election of the Contractor and at his expense.

**S-211.04--Maintenance.** The Contractor shall, at his expense, preserve, protect, replace, and do other work necessary to maintain the topsoil in a satisfactory and acceptable condition from the time of placing until final acceptance.

### **COMPENSATION**

**S-211.05--Method of Measurement.** Contractor furnished topsoil will be measured by the cubic yard (LVM), at the point of delivery.

Topsoil specified to be obtained from sources within the right-of-way will be measured by the square yard of the surface acceptably plated with topsoil.

Topsoil stripped from construction limits will also be included in the measurement of the applicable excavation item as prescribed in S-203.13.

**S-211.06--Basis of Payment.** Topsoil for slope treatment, complete in place and measured as prescribed in S-211.05, will be paid for at the contract unit price per cubic yard or per square yard which shall be full compensation for completing the work specified.

Payment will be made under:

#### **Materials Specified to be Obtained from the Right-Of-Way**

**S-211-A:** Topsoil for Slope Treatment - per square yard

#### **Materials obtained from Sources outside the Right-Of-Way**

**S-211-B:** Topsoil for Slope Treatment (Contractor Furnished) (LVM) - per cubic yard

**S-212.01--Description.** This work shall consist of plowing, loosening and pulverizing the soil in the area to be seeded to form suitable beds to receive erosion control items as set out hereunder. Areas prepared and finished under these specifications shall be in reasonably close conformity with established lines, grades and without appreciable humps or depressions. This item shall also consist of furnishing, spreading and incorporating fertilizers of the type (s) and the amount designated on the plans.

**MATERIALS**

**S-212.02--Fertilizers.** Amounts and types of fertilizers will be as indicated on the plans and in the proposal, or as directed by the Engineer. All fertilizers shall comply with the State Fertilizer Laws in effect on the date of the letting and, unless otherwise stipulated, with the requirements set out in the following Subsections:

- Agricultural Limestone..... S-715.02
- Manufactured Fertilizers..... S-715.02

All fertilizers shall be transported in containers which will ensure proper protection and handling. Fertilizers allowed to collect moisture or get wet causing the material to become hard or lumpy, will be rejected.

**CONSTRUCTION REQUIREMENTS**

**S-212.03--Equipment.** All equipment necessary for soil preparation and for properly handling, storing, spreading and incorporating the fertilizers into the prepared soil shall be provided.

**S-212.04--Ground Preparation.** Ground preparation shall consist of plowing and pulverizing the soil within the area to be planted or seeded. Unless otherwise stipulated, the soil shall be prepared to a depth of not less than four inches. The soil area shall be thoroughly disked and harrowed until well pulverized to the full depth and the area shall present a smooth, uniform, loose appearance with all large clods, earth balls, boulders, stumps, large roots or other particles which will interfere with the work removed.

The Engineer may, at his discretion, authorize elimination of ground preparation on shoulders and fill slopes, or other areas where the soil is sufficiently loose and pulverized. Where loamy topsoil is to be applied to the area the depth of the preparation may be reduced to two inches or, when permitted by the Engineer, the necessary disking and harrowing may be performed after the loamy topsoil has been placed.

If wetting of the soil is necessary for proper ground preparation the Contractor shall supply sufficient water therefor.

Full advantage shall be taken of weather and soil conditions and no attempt shall be made to prepare the soil while it is wet or in an otherwise non-tillable condition.

In any case the soil shall be so pulverized and cultivated as to provide a suitable bed for planting or seeding operations and the area shall be true to the lines and grades as established.

**S-212.05--Application of Fertilizers and Agricultural Limestone.** The Contractor shall furnish all equipment necessary to properly handle, store, uniformly spread, and incorporate the specified application of fertilizer.

The type and rate of application of each fertilizer to be applied will be indicated on the plans, determined by soil tests, or directed. The amounts and types of fertilizers shall be applied uniformly on the areas to be planted or seeded and uniformly incorporated into the soil.

Fertilizers shall be applied on individual areas of not more than approximately three acres. The Engineer will determine the actual amounts of fertilizers to be applied on each area. For agricultural limestone, a tolerance of fifteen (15) percent will be permitted without correction. For all other types of fertilizer, a tolerance of ten (10) percent will be permitted without correction. Areas deficient in application by more than these tolerances shall be corrected by reapplication in a manner approved by the Engineer. For areas on which fertilizer has been placed in excess of the tolerance permitted the amounts in excess of the tolerances will be deducted from the measured quantities.

All fertilizer shall be incorporated within twenty-four (24) hours following spreading unless otherwise directed. Incorporation of fertilizer into soils other than topsoil shall include standard ground preparation in accordance with S-212.04. When topsoil is used, the fertilizer shall be incorporated into the top three inches.

Unless otherwise specified, when fertilizer is to be applied to existing vegetation, incorporation shall be accomplished immediately after the application by mowing the vegetation to a height of approximately four inches.

### **COMPENSATION**

**S-212.06--Method of Measurement.** The volume of fertilizer, applied as ordered in accepted work will be measured in tons of 2,000 pounds, but deduction will be made for the volume of fertilizer which was originally incorporated in grassed or seeded areas which are not accepted or which are necessarily refertilized and replanted. Topsoil will be measured and paid for as set forth in S-211.

Ground Preparation will not be measured for payment unless a specific pay item is set up in the contract, in which case it will be measured in square yards. When the contract does not specifically include a pay item for Ground Preparation, such construction shall be considered a necessary part of the work in completing the various planting or seeding items and is a responsibility to be assumed by the Contractor in connection with such respective pay items.

**S-212.07--Basis of Payment.** Fertilizer will be paid for at the contract unit price bid per ton for fertilizer of the specified type, complete in place, which price shall be full payment for furnishing, spreading and incorporating fertilizer of the type and amount specified, for ground preparation and for all labor, equipment, tools, and incidentals necessary to complete the work.

When compensation is to be made for ground preparation it shall be paid for at the contract unit price bid per square yard for Ground Preparation, which price shall be full payment for all equipment, tools, labor, and incidentals necessary to complete the work.

Payment will be made under:

<b><u>S-212-A:</u></b> Agricultural Limestone	- per ton
<b><u>S-212-B:</u></b> Commercial Fertilizer ( _____ ) Type	- per ton
<b><u>S-212-C:</u></b> Blank	
<b><u>S-212-D:</u></b> Super Phosphate	- per ton
<b><u>S-212-E:</u></b> Ammonium Sulphate	- per ton
<b><u>S-212-F:</u></b> Ammonium Nitrate	- per ton
<b><u>S-212-G:</u></b> Nitrate of Soda	- per ton
<b><u>S-212-H:</u></b> Muriate of Potash	- per ton
<b><u>S-212-I:</u></b> Ground Preparation	- per square yard

**Section S-213 - Blank.**

**S-214.01--Description.** This work shall consist of furnishing the specified seeds and treatment materials, treating the seeds, and planting the seeds in a prepared and approved seedbed; covering the seeds and compacting the seedbed; and providing plant establishment on designated areas. All the work shall be in accordance with the plans and these specifications.

### **MATERIALS**

**S-214.02--Material Requirements.** Seeds shall meet the requirements of S-715.03, subject to the provisions of this subsection. The Contractor shall acquire seed from seedmen registered with the Mississippi Department of Agriculture and Commerce.

Except for the germination test (Reference is made to S-715.03), bags of seeds properly labeled or tagged according to law and indicating characteristics meeting or exceeding the requirements of these specifications will be acceptable for planting.

When pretested seeds are planted, a minus tolerance of five percent of the specified germination percentage will be allowed without adjustment. Seeds failing to comply by more than five percent may be planted, provided the rate of seeding is increased by one hundred (100) percent of the deficiency with the same or approved seeds, without additional compensation.

The Engineer may permit the Contractor to plant non-tested seeds, provided the seeds are properly tagged and have indicated characteristics meeting the requirements (without tolerance) of these specifications. If the seeds are planted, the Contractor shall assume full responsibility for the specified percent germination of the seeds. Acceptance or resowing will be based on the results of the subsequent growth and coverage. If the subsequent growth and coverage indicate a deficiency in excess of five percent, the deficiency shall be corrected by immediately resowing an amount of seeds equal to two hundred (200) percent of the observed deficiency with the same or approved seeds without additional compensation.

Ground preparation and fertilizing shall be in accordance with S-212.

Mulching shall be in accordance with S-215.

### **CONSTRUCTION REQUIREMENTS**

**S-214.03--Construction Details.** Prior to planting the seeds, topsoil (if specified), ground preparation, and fertilizing shall have been satisfactorily performed and the area approved by the Engineer.

Seeding may be required for temporary protection or for establishment of permanent ground cover. The plans will indicate temporary seeding.

The rates of application, kinds, and the planting dates of seeds shall be as specified herein. The Engineer will determine the actual quantity of seeds to be applied on individual areas of not more than approximately three acres.

Seeding mixtures for the various project conditions or degree of completion and seasonal limitations shall be as shown on the following tables:

MIXTURE NO. 1 (State-Wide)

Spring & Summer (March 1 to Aug. 31)

- |                        |                  |
|------------------------|------------------|
| 1. Common Bermudagrass | @ 15 pounds/acre |
| 2. Bahiagrass          | @ 40 pounds/acre |

MIXTURE NO. 2 (State-Wide)

Spring & Summer (March 1 to Aug. 31)

- |                        |                  |
|------------------------|------------------|
| 1. Common Bermudagrass | @ 15 pounds/acre |
| 2. Bahiagrass          | @ 40 pounds/acre |
| 3. Lovegrass           | @ 15 pounds/acre |
| 4. Sericea Lespedeza   | @ 25 pounds/acre |

MIXTURE NO. 3 (State-Wide)

Fall & Winter (Sept. 1 to Nov. 15)

- |                        |                  |
|------------------------|------------------|
| 1. Common Bermudagrass | @ 15 pounds/acre |
| 2. Bahiagrass          | @ 40 pounds/acre |
| 3. Crimson Clover      | @ 20 pounds/acre |

MIXTURE NO. 4 (Interstate 20 North)

Fall & Winter (Sept. 1 to Nov. 15)

- |                                       |                  |
|---------------------------------------|------------------|
| 1. Common Bermudagrass                | @ 15 pounds/acre |
| 2. Bahiagrass                         | @ 40 pounds/acre |
| 3. Sericea Lespedeza                  | @ 25 pounds/acre |
| 4. Fescue (Ky-31)(Sept. 1 to Nov. 15) | @ 30 pounds/acre |

## MIXTURE NO. 5 (State-Wide)

Winter ( Nov. 16 to Feb. 28)

- |  |                  |
|--|------------------|
| 1. Bahiagrass (Pensacola, Wilmington or Argentine) | @ 40 pounds/acre |
| 2. Rye Grain (Marshall)                            | @ 20 pounds/acre |
| 3. Crimson Clover (Tibbee, Dixie, Autauga, Chief)  | @ 10 pounds/acre |
| 4. Bermuda (unhulled) (Common)                     | @ 25 pounds/acre |

## USE:

- Mixture No. 1 and 3 for seasonal vegetation schedule on all paving projects.
- Mixture No. 2 and 4 for seasonal vegetation schedule on grade and drain projects. In Mixture No. 4, crimson clover will be substituted for fescue (Ky-31) especially south of Interstate 20. Lovegrass and Sericea Lespedeza seed specified to be sown in Mixtures 2 and 4 will be sown only on high fill and backslope areas selected by the Engineer. Mixture No. 5 is intended for use on LSBP projects only or as required for temporary erosion control. This mixture will not be accepted as permanent erosion control on other projects without the approval of the State Aid Engineer.
- Legume seeds treated with inoculant must be sown separately from grass seed treated with Thiram. The use of separate sowing equipment is also recommended to prevent germination deterioration of each type seed.
- The recommended quantity of fertilizer for all of the above listed seed mixtures is as follows:

800 pounds	10-20-10	per acre
600 pounds	13-13-13	per acre
200 pounds	Ammonium Nitrate	per acre

Legume seeds shall be treated in accordance with S-715.03.4 immediately before sowing. Seeds shall be uniformly sown over the entire area with approved mechanical seeders. Seeds of different sizes may necessitate separate sowing. Should legume seeds become dry, they shall be reinoculated.

Seeding shall not be done during windy weather or when the ground is frozen, extremely wet, or in an untillable condition.

All seeds shall be covered lightly with soil by raking, rolling, or other approved methods, and the area compacted with a cultipacker.



When specified, mulching shall be performed in accordance with the requirements of S-215 as soon as practicable (no later than twenty-four (24) hours after seeding unless weather conditions are such that mulch cannot be placed).

**S-214.04--Plant Establishment.**

**S-214.04.1--Plant Establishment and Maintenance.** When an area is seeded or top seeded, with or without the addition of mulch, growth or coverage shall be considered acceptable when a satisfactory stand and growth of in season plantings have sufficiently covered the area seeded to provide ample erosion protection exclusive of any protective cover provided by the mulch. It shall be the responsibility of the Contractor that the seed planted has produced a living and growing vegetative cover at the time of acceptance.

Plant establishment and maintenance shall consist of the necessary protection of the seeded or top seeded areas and other operations of maintenance including watering, weeding, mowing, repairing, and reseeding or all areas damaged or eroded as a result of the Contractor's operations, negligence or by normal rains or storms.

Inspection for overall project acceptance will not be made until a minimum period of thirty (30) days has elapsed after the final planting of seed.

**COMPENSATION**

**S-214.05--Method of Measurement.** Seeding, complete and accepted, will be measured by the acre.

Except as provided under S-107.17, no measurement for payment will be made for any materials or work required under S-214.04.

Except for materials and work required under S-214.04, accepted quantities of topsoil, fertilizing, and mulching will be measured as prescribed in the respective sections for such items.

Watering for seeding will not be measured for separate payment.

**S-214.06--Basis of Payment.** Seeding, measured as prescribed in S-214.05, will be paid for at the contract unit price bid per acre which shall be full compensation for completing the work specified.

Payment will be made under:

**S-214-A:** Seeding - per acre

**S-215.01--Description.** This work shall consist of furnishing, transporting, placing, and anchoring vegetative mulch on slopes, shoulders, and other areas indicated on the plans, or designated.

### **MATERIALS**

**S-215.02--Material Requirements.** The vegetative materials for mulch shall meet the requirements of S-715.05.

It is intended that Type I Vegetative Materials shall be used when available. When it is determined by the Engineer with the concurrence of the State Aid Engineer that Type I Vegetative Material is not reasonably available, Type II Vegetative material will be permitted as provided in S-715.05.

Bituminous material for mulch shall be Emulsified Asphalt, Grade SS-1, meeting the requirements of S-702.07.

**S-215.03--Equipment.** Mulching equipment shall be capable of maintaining a constant air stream which will blow or eject controlled quantities of mulch in a uniform pattern. If asphalt is used, a jet or spray nozzle for applying uniform, controlled amounts of asphalt to the vegetative material as it is ejected shall be located at or near the discharge spout.

Mulch stabilizers shall consist of dull blades or disks without camber and approximately 20 inches in diameter. The disks shall be notched, shall be spaced at approximately 8 inches and shall be equipped with scrapers. The stabilizer weight shall be approximately 1000 - 1100 pounds, shall have a working width of no more than 8 feet, and shall be equipped with a ballast compartment so that, when directed, weight can be increased.

### **CONSTRUCTION REQUIREMENTS**

**S-215.04--Construction Details.**

**S-215.04.1--Placement of Vegetative Mulch.** Mulching shall be placed uniformly on designated areas within 24 hours following seeding unless weather conditions are such that mulching cannot be performed. Placement shall begin on the windward side of areas and from tops of slopes. In its final position the mulch shall be loose enough to allow air to circulate but compact enough to partially shade the ground and reduce erosion.

The baled material shall be loosened and broken thoroughly before it is fed into the machine to avoid placement of unbroken clumps.

**S-215.04.2--Rates of Application and Anchoring Mulch.** The Engineer will designate the rate of application of vegetative mulch within the limits of one (1) to three (3) tons per acre. The mulch shall be anchored by either the use of a mulch stabilizer or by tacking with bituminous material as directed by the Engineer. If bituminous material is used, the rate of application shall be 90 to 150 gallons per ton of vegetative material. If a mulch stabilizer is used, the mulch shall be punched into the soil for a minimum depth of 1 inch.

Where steep slopes or soil conditions are such that anchoring cannot be performed satisfactory with a mulch stabilizer the Engineer will require that bituminous material be applied at the time or immediately following the mulch placement. When mulch stabilizers are used, anchoring the mulch shall be performed along the contour of the ground surface. As the work progresses, the Engineer will determine the actual rate of application of the vegetative mulch and the bituminous material (if used) on each area not to exceed three acres. For vegetative mulch, a tolerance of fifteen (15) percent will be permitted without correction. For bituminous material (if used), a tolerance of ten (10) percent will be permitted without correction. Areas deficient in application by more than these amounts shall be corrected by reapplication in a manner approved by the Engineer. For areas on which vegetative material has been placed in excess of the tolerance permitted, that portion of the material placed in excess of the tolerance allowed will be deducted from the measured quantities. In the event an excess of vegetative material has been placed in a quantity deemed by the Engineer to be undesirable, the Contractor shall remove and replace all material placed on that area at no additional cost to the project.

**S-215.05--Protection and Maintenance.** The Contractor shall maintain and protect mulched areas until final acceptance of the project. He shall take every precaution to prevent unnecessary foot and vehicular traffic and shall repair and restore immediately any displacement of mulch without extra compensation.

At appropriate times determined by the Engineer, the Contractor shall mow or otherwise remove or destroy all undesirable growth on all areas mulched to prevent competition with the desired plants and to prevent reseeding of undesirable growth. All mowing shall be a part of protection and maintenance.

**COMPENSATION**

**S-215.06--Method of Measurement.** Accepted quantities of vegetative material for mulch will be measured in tons of 2000 pounds.

The weight for measurement will be the product of the number of bales acceptably placed and the average weight per bale as determined on approved scales provided by the Contractor.

Anchoring of vegetative mulch, whether by use of a mulch stabilizer or by application of bituminous material, will not be measured for separate payment unless provided for in the plans or in accordance with S-104-02.

Asphalt emulsion, when included as a pay item, will be measured in gallons.

**S-215.07--Basis of Payment.** Vegetative material for mulch will be paid for at the contract unit price per ton, which shall be full compensation for completing the work specified. Asphalt emulsion will be measured in gallons.

Payment will be made under:

**S-215-A:** Vegetative Materials for Mulch - per ton

**S-215-B:** Mulch, Asphalt Emulsion - per gallon

**Sections S-216 thru S-225 - Blank.**

**S-226.01--Description.** This work shall consist of furnishing, transporting, and planting approved grass sod in accordance with the plans and these specifications. This work shall also include plant establishment as specified and required to assure satisfactory growth of the solid sod.

### **MATERIALS**

**S-226.02--Material Requirements.** Unless otherwise specified, solid sod shall be bermuda (common), bahia, or other approved sod species and shall be live, fresh, growing grass with at least one and one-half inches of soil adhering firmly to the roots when placed. The sod shall be reasonably free from obnoxious weeds or other grasses, and shall not contain any matter deleterious to its growth, or which might affect its subsistence or hardiness when transplanted. The sod shall be in strips or blocks at least eight inches by eight inches and reasonably free from ragged edges.

All sod shall be harvested from areas where the topsoil is fertile, and the areas shall have been grazed or mowed sufficiently to form a dense turf. After approval, the area from which the solid sod is to be harvested shall be closely mowed and raked, if deemed necessary, to remove excessive top growth and debris.

When specified, the solid sod material shall be the kind specified, nursery grown, healthy, free from damage, and free from obnoxious weeds and grasses. The nursery grown sod shall be in blocks at least eight inches by eight inches by one inch and reasonably free of ragged edges.

All solid sod materials shall be approved by the Engineer prior to transplanting.

Fertilizer used in the construction shall be in accordance with S-212.

### **CONSTRUCTION REQUIREMENTS**

#### **S-226.03--Construction Details.**

**S-226.03.1--Procuring and Handling Sod.** Approved sod cutters shall be used for cutting the sod into strips or blocks. Care shall be exercised at all times to retain the native soil on the roots of the sod during the process of excavating, hauling, and planting.

The sod shall be transplanted within twenty-four (24) hours after arriving on the project, unless it is stacked in a manner satisfactory to the Engineer. All sod in stacks shall be kept moist and protected from exposure to the wind and sun and from freezing. In no event shall more than three days elapse between the cutting and planting of the sod without approval of the Engineer.

**S-226.03.2--Grading of the Area to Receive Solid Sodding.** Prior to ground preparation for solid sodding, all excavating, shaping, and dressing shall have been completed in such a manner that the foundation for the sod has the proper cross section, line, and grade and so that the sod after placement will be flush with or slightly below the adjacent final ground line.

**S-226.03.3--Ground Preparation and Fertilizing.** After the area has been graded as required, the specified types and quantities of fertilizers shall be uniformly spread and then incorporated by standard ground preparation in accordance with S-212. The prepared area shall be at an approved moisture content and shall present a smooth, uniform surface with reasonably close conformity to the specified line, grade, and cross section. After approval by the Engineer of the prepared and fertilized area, sodding shall follow immediately.

**S-226.03.4--Planting Sod.** The sod shall be placed on the prepared surface with edges in close contact and starting at the lowest point and working upward. Cracks between blocks of sod shall be filled with small pieces of fresh sod, and all cracks too small for sod shall be filled by a light dressing of approved soil. The entire sodded area shall then be compacted and watered to the satisfaction of the Engineer. Light rollers, hand tamps, or other approved equipment shall be used for compacting.

On areas which the Engineer deems that the sodding might slide due to the height and slope of the surface or nature of the soil, the sod shall be "pegged" with wooden pegs driven through the sod blocks into firm earth. Pegs shall be at intervals deemed suitable to hold the sod in place.

**S-226.03.5--Limitations.** Solid sodding shall be performed only when weather and soil conditions are deemed by the Engineer to be suitable for proper placement.

**S-226.04--Plant Establishment.** Plant establishment shall consist of preserving, protecting, replacing, watering, mowing, and other work necessary to keep the sod in a satisfactory condition at all times until final acceptance.

A satisfactory growth of solid sodding shall be understood to mean a healthy, living, and growing grass turf which has been planted on an approved prepared foundation and has been maintained in accordance with the requirements of these specifications.

**COMPENSATION**

**S-226.05--Method of Measurement.** Solid sodding, complete in place and accepted, will be measured by the square yard.

If solid sodding is required by the contract, or ordered by the Engineer, on a section graded under a previous contract, required excavation, exclusive of trenching out and fine grading, will be measured under the appropriate excavation item of the contract, or as Extra Work.

Fertilizer ordered and acceptably used will be measured and paid for as prescribed in S-212.

**S-226.06--Basis of Payment.** Solid sodding will be paid for at the contract unit price per square yard which shall be full compensation for completing the work specified.

Payment will be made under:

**S-226-A:** Solid Sodding - per square yard

**S-227.01--Description.** This work shall consist of furnishing, placing, and maintaining excelsior blanket on seeded, or other designated areas in accordance with the requirements shown on the plans and these specifications.

### **MATERIALS**

**S-227.02--Material Requirements.** The excelsior blanket shall meet the requirements of S-715.09.2.

### **CONSTRUCTION REQUIREMENTS**

**S-227.03--Construction Details.** The area to be covered shall be prepared, fertilized, and vegetated before the blankets are placed. Immediately following the planting operations, the blankets shall be laid evenly, smoothly, and in contact with the soil throughout and with the fabric net on top of the blankets. Asphalt-coated mulch should be omitted from all areas receiving the excelsior blanket.

In ditches, the blankets shall be unrolled in the direction of water flow. When two or more strips are required to cover a ditch area, they shall overlap a minimum of four inches with the upgrade width on top. In case a strip is spliced lengthwise, the edges of the strips shall overlap a minimum of six inches with the upgrade section on top.

When used on slopes, the blankets may be placed either horizontally or vertically on the slope with the edges and ends of adjacent strips butted tightly against each other.

Each strip shall be stapled in three rows (each edge and center with the center row alternately spaced) with staples spaced not more than four feet longitudinally. When using two or more strips side by side on slopes, a common row of staples shall be used on the adjoining strips to secure the outside netting strand of each strip. Ends of strips shall be stapled at one foot intervals. Staples shall be firmly embedded in the underlying soil.

**S-227.04--Protection and Maintenance.** The Contractor shall maintain and protect the excelsior blankets until final acceptance or until the Engineer has determined that the blanket has served its useful life, whichever occurs first. Maintenance shall consist of repairs necessitated by erosion, wind, fire, or other cause.



**COMPENSATION**

**S-227.05--Method of Measurement.** Excelsior blanket, installed as specified, complete in place, and accepted, will be measured by the square yard of surface area covered.

**S-227.06--Basis of Payment.** Excelsior blanket will be paid for at the contract unit price per square yard, which shall be full compensation for completing the work specified.

Payment will be made under:

**S-227-A:** Excelsior Blanket - per square yard

**Section S-228 - Blank.**

**S-229.01--Description.** This work shall consist of constructing paved ditches of portland cement concrete, as specified in the contract, constructed in accordance with the provisions and requirements of these specifications, and in reasonably close conformity with the lines, grades, typical cross sections, and locations shown on the plans or established by the Engineer.

### **MATERIALS**

#### **S-229.02--Material Requirements.**

**S-229.02.1--Portland Cement Concrete Paved Ditches.** The materials used in the construction of portland cement concrete paved ditches shall conform to the applicable provisions and requirements of S-804.

**S-229.02.2--Reinforcement.** Reinforcement shall meet the requirements of S-711.

### **CONSTRUCTION REQUIREMENTS**

#### **S-229.03--Construction Details.**

**S-229.03.1--General.** The foundation for paved ditches shall be formed by excavating to the required depth and dimensions below the prepared finished surface grade of the paved ditch.

The foundation shall be thoroughly compacted by hand tamping or other approved method. Soft, spongy, or other unsuitable material shall be removed as directed, and replaced with suitable material thoroughly compacted in six inch layers.

The forms used in this construction may be wood or metal; shall have a depth equal to the prescribed edge thickness of the paved ditch; and shall be of sufficient strength to withstand the weight of the concrete and the pressure incidental to vibration or compaction without bulging or displacement. Forms shall be securely staked and braced.

Reinforcement, if specified, shall be placed in a manner that will insure its proper position in the paved ditch section after all concrete is placed.

**S-229.03.2--Portland Cement Concrete Paved Ditches.** Unless otherwise specified on the plans, the portland cement concrete paved ditches shall be constructed of Class "C" concrete, mixed and placed in accordance with the applicable requirements of S-804, and cured in accordance with the requirements of S-804 or by other approved methods. The limitations of mixing, placing, and curing shall conform to the requirements of S-804.

A template mounted on the side forms shall be used in striking off and finishing the surface of the concrete to the required shape and dimensions. The entire unit shall be constructed monolithic with smooth fillets or curves at all angles or breaks in flow lines. Concrete shall be placed beginning at the bottom of the slope and progressing upward. The finished surface shall be given a Class 6, Floated Surface Finish in conformity with the requirements of S-804.03.19.5.

Expansion joints shall be constructed at the locations indicated on the plans or as directed, and shall be of the specified materials and dimensions.

**S-229.03.3--Backfilling and Cleaning Up.** After the concrete has set sufficiently, the forms shall be removed and the spaces around the paved ditch shall be backfilled with approved material and thoroughly compacted without damage to the paved ditch. The adjacent ditch slopes shall be neatly trimmed to the required section, and all surplus material disposed of as directed.

### **COMPENSATION**

**S-229.04--Method of Measurement.** The completed and accepted portland cement concrete paved ditch will be measured in cubic yards.

Excavation required for trenching and fine grading will not be measured for separate payment.

Other required excavation will be measured for payment under the applicable excavation items.

**S-229.05--Basis of Payment.** Portland cement concrete paved ditch will be paid for at the contract unit price per cubic yard, which shall be full compensation for completing the work specified.

Payment will be made under:

**S-229-A:** Portland Cement Concrete Paved Ditch - per cubic yard

**S-230.01--Description.** This work consists of furnishing and installing a layer of bituminous treated roving to stabilize newly planted soil areas in ditches and on slopes in accordance with these specifications and at locations shown on the plans or as directed by the Engineer.

**S-230.02--Materials.**

**S-230.02.1--General.** The type of roving material (fiberglass or polypropylene) shall be at the option of the Contractor unless otherwise specified and shall meet the applicable requirements of S-715.09.6.

The glass fibers or fibrillated polypropylene yarn shall be wound onto cylindrical packages so that the roving can be continuously fed through an ejector driven by compressed air and expanded into a mat. The fibers or yarn shall be lightly bound together in a ribbon form, without the use of clay, starch, or other deleterious substances. The material shall not contain petroleum solvents, or other agents known to be toxic to plant or animal life.

The roving material shall not be exposed to moisture prior to placement.

**S-230.02.2--Bituminous Material.** The bituminous material used for securing the roving to the existing soil shall be Emulsified Asphalt, Grade SS-1, meeting the requirements of S-702.07.

**S-230.03--Construction Requirements.**

**S-230.03.1--Equipment.** An air compressor shall be used in conjunction with applying the glass fiber or polypropylene yarn. A compressor capable of supplying forty (40) cubic feet per minute at 80 to 100 pounds per square inch is required. One air gun specifically designed for spraying glass fibers or polypropylene yarn, sufficient three-eighths inch diameter rubber hose for application, and at least one bucket container shall be furnished for applying the material. Three spools or packages may be run simultaneously from a 125 cubic foot compressor. Equipment which cuts or breaks the roving will not be permitted. Equipment for applying the asphalt shall be capable of applying the material in a uniform spray at the rate specified.

**S-230.03.2--General.** The bituminous treated roving shall be applied over designated areas within 24 hours following the planting or seeding operations. The designated areas shall be free of all objects including the vegetative material for mulch that would keep the roving material from being in direct contact with soil throughout the entire area to be treated.

The upgrade and downgrade ends of the bituminous treated roving shall be buried in a six inch minimum vertical slot and the soil tamped firmly against it.

The bituminous treated roving shall be applied uniformly over the planted areas at the following rate:

- a) Bituminous Treated Fiberglass Roving: 0.50 pounds ( $\pm$  20%) per square yard; or
- b) Bituminous Treated Polypropylene Roving: 0.20 pounds ( $\pm$  20%) per square yard.

The rate of distribution will be determined from the number of spools or packages of roving used on each area and the average weight of the spools or packages. A sample of at least five spools or packages designated at random by the Engineer will be taken and weighed and the average weight to the nearest pound per spool or package will be used for the truckload from which the sample was taken.

Immediately following the spreading of roving, the asphaltic material shall be applied uniformly over the roving at the rate of 0.50 gallons ( $\pm$  20%) per square yard.

The Contractor shall be required to apply additional asphaltic material, if needed, to penetrate through the roving in sufficient quantity to secure the roving to the soil.

**S-230.03.3--Protection and Maintenance.** The Contractor shall maintain and protect the bituminous treated roving mat until release of maintenance or until the Engineer has determined that the mat has served its useful life, whichever occurs first. Maintenance shall consist of repairs made necessary by erosion, wind, fire, or any other cause.

**S-230.04--Method of Measurement.** Bituminous treated roving installed as specified, complete in place and accepted, will be measured by the square yard of surface area covered.

The additional materials required for terminal slots and materials placed outside the limits of the designated area(s) requiring treatment will not be measured for payment.

**S-230.05--Basis of Payment.** Bituminous treated roving measured as prescribed above will be paid for at the contract unit price per square yard, which shall be full compensation for completing the work.

Payment will be under:

**S-230-A:** Bituminous Treated Roving - per square yard

**S-231.01--Description.** This work shall consist of furnishing, placing, and maintaining erosion control fabric on seeded or other designated areas in accordance with the requirements of the plans and these specifications.

### **MATERIALS**

**S-231.02--Materials.** The erosion control fabric shall consist of a flexible knitted construction of high strength degradable yarn with uniform openings interwoven with strips of biodegradable paper and meeting the following requirements:

Width - 48 inch minimum

Weight - 0.2 pounds per square yard (approximate)

Staples for securing the fabric in place shall be "U" shaped, made from eleven (11) gage or heavier steel wire, have a width one to two inches at the throat, and be a minimum of six inches from top to bottom after bending.

For erosion control fabric, the Contractor shall forward to the Engineer three copies of the manufacturer's certification for each shipment of the fabric stating the number of rolls furnished, and that the material complies with the requirements of the specifications.

For staples, the Contractor shall forward to the Engineer three copies of the manufacturer's or distributor's certification showing the wire size for each shipment of staples.

The certifications by the manufacturer or distributor will be prima facie evidence of the materials meeting the above requirements. All erosion control fabric and staples will, however, be subject to approval by the Engineer.

### **CONSTRUCTION REQUIREMENTS**

**S-231.03--Construction Requirements.** The areas to be covered shall be prepared, fertilized, and vegetated as specified before the fabric is installed. The mulch material shall be omitted from areas receiving the fabric. Immediately following the planting operation, the fabric shall be installed by unrolling it in the direction of water flow and draping it loosely, without folds or stretching, so that continuous ground contact is maintained. The ends of the fabric at the beginning and end of each area to be covered shall be folded and placed in an anchor trench at least four inches deep, and stapled in the trench on approximately twelve (12) inch centers, backfilled, and tamped.

When two or more strips are required to cover an area, they shall overlap a minimum of four inches. In case a strip is to be spliced lengthwise, the edges of the strips shall overlap a minimum of six inches with the upgrade section on top. Each strip shall be stapled in three rows (each edge and center with center row alternately spaced) with staples spaced not more than four feet longitudinally. The ends of all strips spliced lengthwise shall be stapled at one foot intervals across the entire width of the fabric.

Where heavy concentrations of water or extremely erodible soil conditions exist, erosion checks shall be installed at 50 foot intervals as directed by the Engineer. Erosion checks shall be a row of staples 12 inches on center across the width of the fabric perpendicular to the flow line.

All staples shall be firmly embedded in the underlying soil.

**S-231.04--Protection and Maintenance.** The Contractor shall maintain and protect the erosion control fabric until final acceptance or until the Engineer has determined that the fabric has served its useful life, whichever occurs first. Maintenance shall consist of repairs made necessary by erosion, wind, fire or any other cause.

### **COMPENSATION**

**S-231.05--Method of Measurement.** Erosion control fabric installed as specified, complete in place, and accepted will be measured by the square yard of surface area covered.

The additional fabric material required for overlaps, anchor slots, and over-width of strips will not be measured for payment.

**S-231.06--Basis of Payment.** This work measured as prescribed above will be paid for at the contract unit price per square yard, which shall be full compensation for completing the work specified.

Payment will be made under:

**S-231-A:** Erosion Control Fabric - per square yard

**S-232.01--Description.** This work consists of furnishing and installing geotextile fabric for stabilization of embankments and subgrades as shown in the plans and in conformance with these specifications.

**S-232.02--Material.** The fabric and incidental materials for this work shall meet the requirements of S-714.13.

**S-232.03--Construction Details.** A subgrade which is to receive geotextile fabric shall be shaped and compacted to a smooth finish and free of loose material and sharp objects. An embankment site shall be cleared and graded to establish a relatively smooth surface. Trees and stumps are to be cut off at ground line and sawdust or sand placed over these areas to provide a cushion for the fabric.

The fabric shall be placed as smooth as possible and free from tension, stress, folds, wrinkles or creases.

Where more than one layer of fabric is required, all joints of the bottom layer shall be sewn to develop the required fabric strength perpendicular to the joint. The top layer and single layer installations of fabric may be overlapped a minimum of two feet at each joint or sewn.

Fabrics which weigh less than eight ounces per square yard shall be factory or field sewn with a "J" type seam. Heavier weight fabrics shall be factory sewn with two parallel bag type seams approximately one-fourth inch apart or field sewn with an additional seam zigzagged across the two parallel seams.

Securing pins with washers shall be inserted along a line through the midpoint of any overlap or sewn seam at intervals required by the Engineer to prevent movement of the fabric until covered.

The subsequent course of material shall be back-dumped in such a manner as to avoid damage to the underlying fabric. No equipment will be allowed to operate over the fabric until it is covered with a layer of material of sufficient thickness to protect the fabric installation. When the underlying soil is very unstable, the two outer one-third portions of an embankment layer shall be placed approximately 25 feet in advance of the center one-third portion to prevent excessive mudwave movements and damage to the fabric installation.

The Contractor shall provide equipment necessary for placing the fabric in the position and location as detailed on the plans.



**S-232.04--Method of Measurement.** Fabric placed in accordance with these specifications and as directed by the Engineer will be measured by the square yard of surface area covered. Any overwidth of material installed and additional material required for laps or sewing will not be measured.

**S-232.05--Basis of Payment.** The accepted quantities of fabric will be paid for at the contract unit price per square yard. This payment will be full compensation for furnishing and placing the fabric, pins, lapping, sewing, maintaining the fabric until covered, and satisfactorily completing the work.

Payment will be made under:

**No. S-232-A:** Geotextile Fabric Stabilization  
(Type\_\_\_\_) (AOS\_\_\*) - per square yard

\* When not designated, see S-714.13.

**S-233.01--Description.** This work shall consist of furnishing, constructing, maintaining, and removing a water permeable filter type of fence for the purpose of removing suspended soil particles from the water passing through it in accordance with the requirements shown on the plans and these specifications.

The quantity of temporary silt fence to be installed will be affected by the actual conditions which occur during the construction of the project.

It is understood that measurement and payment for temporary silt fence will be made only when ordered, and a pay item is included in the bid schedule of the proposal. The quantities for temporary silt fences, when shown in the contract, are estimated for bidding purposes only, and these quantities may be varied dependent upon actual needs for the specific purpose designated.

### **MATERIALS**

**S-233.02--Material Requirements.** The fabric and incidental materials for this work shall meet the requirements of S-714.13.

**S-233.02.1--Posts.** Either wood or steel posts may be used. Wood posts shall be straight enough to provide a fence without noticeable misalignment. Steel posts shall have projections for fastening the wire to the fence.

**S-233.02.2--Filter Fabric.** The filter fabric shall be composed of strong rot-proof synthetic fibers formed into a fabric of either the woven or unwoven type. Either type of fabric shall be free of any treatment or coating which might significantly alter its physical properties after installation. The fabric shall contain stabilizers and/or inhibitors to make the filaments resistant to deterioration resulting from exposure to sunlight or heat. The fabric shall be a pervious sheet of synthetic fibers oriented into a stable network so that the fibers retain their relative position with respect to each other.

The edges of the fabric shall be finished to prevent the outer yarn from pulling away from the fabric. The fabric shall be free of defects or flaws which significantly affect its physical and/or filtering properties. Sheets of fabric may be sewn or bonded together. No deviation from any physical requirements will be permitted due to the presence of the seam.

During all periods of shipment and storage, the fabric shall be wrapped in a heavy duty protective covering which will protect the cloth from sunlight, mud, dust, dirt and debris. The fabric shall not be exposed to temperatures greater than 140°F.

**S-233.02.3--Identification.** Each roll of fabric or container shall be visibly labeled with the name of the manufacturer, type of fabric or trade name, lot number and quantity of material.

**S-233.02.4--Certification.** The Contractor shall furnish to the Engineer three copies of the Manufacturer's certified test report(s) showing results of all required tests and certification that the material meets the specifications. Also forward three copies of the manufacturer's or distributor's certification showing the wire size for each shipment of staples.

### **CONSTRUCTION REQUIREMENTS**

**S-233.03--General.** Silt fences shall be constructed at the locations shown on the plans or as directed by the Engineer.

All posts shall be installed so that no more than three feet of the post protrude above the ground. Extra post for bracing shall be installed as directed by the Engineer. The woven wire shall be securely fastened to the wood posts with staples. When metal posts are used, the wire shall be fastened to the posts with wire or other approved means. The fabric shall be attached to the wire fence with wire or other approved means. The bottom edge of the fabric shall be buried 6 inches below ground surface to prevent undermining. When splicing of the fabric is necessary, two posts shall be installed approximately 18 inches apart and each piece of fabric shall be fastened to both posts.

At the time of or during installation, the fabric will be rejected if it has defects, rips, holes, flaws, deterioration or damage incurred during manufacturing, transporting, storage or installation.

Fabric meeting the requirements of Type II may be installed without the woven wire fence backing, provided:

- A. Post spacing is reduced to six feet or less.
- B. The fabric has been approved by the Engineer, and the manufacturer recommends its use without the woven wire fence backing.
- C. Fence posts shall be inclined toward the runoff source at an angle of not more than 20° from vertical.
- D. Fabric shall be attached to the posts as recommended by the manufacturer.

**S-233.04--Maintenance and Removal.** The Contractor shall maintain the silt fence and shall remove and replace when deteriorated to such extent that it is no longer effective. The Contractor shall remove accumulated siltation when sediment reaches one half the fence height.

Unless otherwise specified, all silt fences shall be removed. Upon removal, the Contractor shall remove and dispose of excess silt accumulations, dress the area to give a pleasing appearance and vegetate all bare areas in accordance with contract requirements. The fence materials will remain the property of the Contractor and may be used at other locations provided the materials are acceptable to the Engineer.

**COMPENSATION**

**S-233.05--Method of Measurement.** Temporary silt fence, complete in place and acceptable will be measured by the linear foot.

**S-233.06--Basis of Payment.** Temporary silt fence will be paid for at the contract unit price per linear foot which shall be full compensation for completing the work specified.

Payment will be made under:

**S-233-A:** Temporary Silt Fence (Type \_\_\_\_ ) (AOS \_\_\_\_\* ) - per linear foot

\* When not designated, see S-714.13.

**Section S-234 - Blank.**

**S-235.01--Description.** This work consists of furnishing, constructing and maintaining baled hay or straw erosion checks for the retention of soil along the toe of fill slopes, around inlets, swale areas, small ditches, sediment basins and other areas as directed by the Engineer in accordance with the requirements shown on the plans and these specifications. Also, the work includes removing and disposing of the erosion checks and silt accumulations as directed by the Engineer.

Measurement and payment for temporary erosion checks will be made only when ordered and a pay item is included in the bid schedule of the proposal. The quantity is estimated for bidding purposes only and will be dependent upon actual conditions which occur during construction of the project.

**S-235.02--Materials.** Approved baled hay or straw material (Type I or II) shall be rectangular in shape with a minimum length of 32 inches and shall meet the requirements of S- 715.05. The wooden stakes used in securing the baled material in place shall be approximately 2" x 2" x 34" meeting the approval of the Engineer.

**S-235.03--Construction Requirements.**

**S-235.03.1--General.** The erosion checks shall be constructed at the locations and according to the requirements shown on the plans or as directed by the Engineer. Erosion checks required along the toe of fill slopes shall be constructed prior to grading operations at the site. For other locations, the erosion checks shall be constructed when directed by the Engineer.

The soil shall be excavated at least three inches in depth to embed the baled material. After securing in place, a sufficient quantity of the excavated material shall be placed around the erosion check and compacted to prevent undermining.

**S-235.03.2--Maintenance and Removal.** The Contractor shall maintain the erosion checks and remove and dispose of silt accumulations that reach 1/2 the bale height or as directed by the Engineer. When the erosion checks are no longer needed, they shall be removed; and the Contractor shall dispose of silt accumulations and treat the disturbed areas in accordance with the contract requirements.

**S-235.04--Method of Measurement.** Erosion checks, complete in place and accepted, will be measured by actual count of the total bales used in constructing, replacing and maintaining the erosion checks.

**S-235.05--Basis of Payment.** Erosion checks will be paid for at the contract unit price per bale and which shall be full compensation for completing, maintaining and removal of the erosion checks and the removal and disposal of silt accumulations.

Payment will be made under:

**S-235-A:** Temporary Erosion Checks - per bale

**S-236.01--Description.** This work consists of excavation and satisfactory disposal of all materials excavated in the construction, clean out, and maintenance of silt basins. This work may also consist of maintenance and removal of existing silt basin constructed on previous projects.

The Contractor shall construct earth dikes and overflow spillways, furnish and install outfall pipe, perforated elbows, perforated risers, and trash racks in silt basins where shown on the plans or as directed by the Engineer. The quantity of silt basins to be placed will be affected by the actual conditions which occur during the construction of the project.

It is understood that measurement and payment for silt basins will be made only when shown on the plans or ordered by the Engineer, and a pay item is included in the bid schedule of the proposal. The quantity is estimated for bidding purposes only and will be dependent upon actual needs during construction of the project.

**S-236.02--Blank.**

**S-236.03--Construction Requirements.**

**S-236.03.1--General.** The Contractor shall excavate silt basins to the dimensions and at the locations shown on the plans or as directed by the Engineer. The silt basins, new or existing, shall be cleaned out as frequently as necessary to have at least 50% of the basin capacity available at all times. The silt basins shall be completely cleaned out and the slopes shaped and dressed for seeding and mulching prior to completion of the project unless otherwise directed by the Engineer. Grassing shall be done in accordance with the provisions contained in the contract for the roadway and will not be measured as a separate item.

**S-236.03.2--Maintenance and Removal.** The silt basins shall be maintained so they will function properly until the Contractor is released from maintenance, all as determined by the Engineer.

All excavated materials shall be utilized in the construction of the basin or roadway embankments except where otherwise directed by the Engineer. Materials not used shall be disposed of as directed by the Engineer.

Upon removal of a silt basin, the pipe, elbows, risers and trash racks may be used at other locations provided they are in condition acceptable to the Engineer. Pipe, elbows, risers and trash racks will remain the property of the Contractor upon completion of the project.

**S-236.04--Method of Measurement.** Silt basin, complete in place and accepted, will be measured per each. Once a silt basin has been constructed, it shall be paid for at the unit price per each; however clean outs or maintenance will need to be performed on that silt basin throughout the length of the project. No additional compensation will be allowed for additional clean outs, maintenance, or removal at the completion of the project.

Maintenance and removal of existing silt basin will be measured per each. Once an existing silt basin has been cleaned out, it shall be paid for at the unit price per each; however additional clean outs or maintenance may need to be performed on that silt basin throughout the length of the project. No additional compensation will be allowed for additional clean outs, maintenance, or removal at the completion of the project.

**S-236.05--Basis of Payment.** Silt basin will be paid for at the contract unit price per each which shall be full compensation for construction, maintaining, removal, grassing and any other work required to make the basin function. Maintenance and removal of existing silt basin will be paid for at the contract unit price per each which shall be full compensation for maintaining, removal, grassing and any other work required to make the basin function.

Payment will be made under:

**S-236-A:** Silt Basin ( Type   \*   ) - per each

**S-236-B:** Maintenance and Removal of Existing Silt Basin - per each

\* Refer to MDOT Roadway Design Standard Drawings for Type.

**Sections S-237 and S-238 - Blank.**

**S-239.01--Description.** This work consists of furnishing materials for, constructing and maintaining temporary slope drains, to include berms, pipe and riprap, as directed by the Engineer in accordance with the requirements shown on the plans and these specifications to control soil erosion and water pollution. Also, the work includes removing and disposing of the temporary slope drains.

This temporary erosion control provision shall be coordinated with the permanent erosion control features to assure economical, effective and continuous erosion control throughout the construction period.

Measurement and payment for temporary slope drains will be made only when a pay item is included in the bid schedule of the proposal. The quantity is estimated for bidding purposes only and may vary depending upon actual construction requirements.

**S-239.02--Materials.** The temporary shoulder berm may be constructed from embankment material.

The temporary pipe shall be 8-inch minimum diameter and leak proof.

The temporary riprap shall be hard, durable stones or broken concrete, angular in shape and shall be of sufficient size to prevent scour where installed.

**S-239.03--Construction Requirements.** Temporary slope drains shall be constructed at the intervals and locations designated or deemed appropriate by the Contractor and approved by the Engineer for channeling runoff waters down embankment slopes and according to the requirements shown on the plans.

Slope drains shall be adequately anchored to the slopes and their outlets constructed or placed to prevent erosion.

Berms may be constructed from embankment material using the heel of a motor grader blade, bulldozer blade or other approved equipment and compacted using the wheels or tracks of same equipment.

Riprap shall be placed in accordance with the plans where the pipe outlet location is subject to scour. The riprap may be end dumped.

Pipe shall be placed in accordance with the plans and extended as required to coincide with the height of embankment by the end of each work day.



Prior to the suspension of grading operations each day, the Contractor shall shape the earthwork in a manner that will direct storm water runoff to the temporary slope drain installations.

The temporary slope drains shall be operated and maintained by the Contractor in an acceptable functional condition until the slopes are protected with permanent erosion control measures.

When the temporary erosion and pollution control installations are no longer required, the Contractor shall remove and dispose of all materials and restore the areas by establishing growth and coverage of vegetative items as required for the remainder of the project.

**S-239.04--Method of Measurement.** Temporary slope drains will be measured by the linear foot of temporary pipe, which includes berms, riprap, and pipe including elbows or special sections. Measurement shall be along the line and grade of the pipe installation from end to end along the centerline of the pipe installed and accepted.

Temporary shoulder berms and temporary riprap will not be measured for separate payment. Their costs shall be included in the per linear foot price bid for temporary slope drains.

**S-239.05--Basis of Payment.** Temporary slope drains, measured as prescribed in S-239.04, will be paid for at the contract unit price per linear foot, which price shall be full compensation for completing and maintaining the work and for the removal and disposal of, when no longer required, all items comprising the temporary slope drains.

Payment will be made under:

**S-239-A:** Temporary Slope Drains - per linear foot

STATE AID 2004 **SECTION S-240 - GEOGRID REINFORCEMENT OF EMBANKMENT SLOPES AND SUBGRADES** STATE AID 2004

**S-240.01--Description.** This work shall consist of furnishing and installing geogrid for reinforcement of embankment slopes and/or subgrades as shown on the plans and in conformance with these specifications.

**S-240.02--Material Requirements.** The geogrid shall meet the requirements of S-722.

**S-240.03--Construction Requirements.**

**S-240.03.1--Preparation of Design Grade of Geogrid.**

**S-240.03.1.1--Preparation of Foundation Soil.** An embankment site that is to receive geogrid reinforcement upon the foundation soil shall be cleared and graded to establish a relatively smooth surface. Trees and stumps are to be cut off at the ground line and sawdust or sand placed over these areas to provide a cushion for the geogrid.

**S-240.03.1.2--Preparation of Basement Soils.** An embankment that is to receive geogrid reinforcement located within the basement soil portion of the embankment shall be brought up to the proper grade as shown on the plans and compacted to the required density. The surface shall be left rough so as to provide for a good bond with the next embankment lift above the geogrid.

**S-240.03.1.3--Preparation of Design Soils or Subgrades.** A design soil or subgrade which is to receive geogrid shall be shaped and compacted to the required density thus providing a smooth finish, free of loose material and sharp objects.

**S-240.03.2--Geogrid Installation.** Geogrid shall be placed coincidently with the compacted lift nearest the design elevation shown on the plans. No partial or half-lift thicknesses are required; however, at no time shall the placement elevation deviate by more than one foot from the design grade.

Correct orientation of the geogrid shall be verified by the Engineer.

Geogrid shall be secured in-place to prevent movement while being covered.

**S-240.03.3--Overlaps and Joints.**

**S-240.03.3.1--Uniaxial Geogrids.** Uniaxial geogrid shall be placed in continuous longitudinal strips in the direction of main reinforcement and adjacent strips do not need to be overlapped. However, if the Contractor is unable to complete a required length with a single continuous length of geogrid, a joint may be made with the Engineer's approval. This joint shall be made for the full width of the strip by interlacing over and under the main reinforcing strands using a solid rod or hollow pipe of similar material and strength. No end joints will be allowed in any two adjacent strips or within 10 feet of the face of the embankment or, in the case of a spill through slope, in front of the abutment. In the event that the length of geogrid reinforcement is greater than the roll length, then end joints will be allowed in adjacent strips, but they cannot be within 75 feet of one another as measured along the length of the strip. Every effort should be made to keep the number of end joints to a minimum and widely spaced throughout the placement area.

**S-240.03.3.2--Biaxial Geogrids.** Biaxial geogrids shall be overlapped three (3) feet between adjacent strips and four (4) feet at the ends except where otherwise noted on the plans and/or in the contract documents.

**S-240.03.4--Placement of Fill over Geogrid.** Fill placement shall conform to the requirements of S-203. Extreme care shall be taken to prevent slippage of the geogrid during fill placement. The fill shall be back dumped and spread on the geogrid in uncompacted lifts of at least six (6) inches before equipment is allowed to continuously operate over it. At no time will tracked equipment be allowed to operate directly upon the geogrid. Rubber tired equipment will be allowed to pass over uncovered geogrid at speeds of less than 5 mph as directed by the Engineer. Any geogrid damage caused by fill placement or equipment movement over the geogrid will be uncovered and repaired as directed by the Engineer at no additional cost to the Project.

**S-240.04--Method of Measurement.** Geogrid of the type specified will be measured by the square yard of surface area covered. Any overwidth of geogrid installed and additional material required for laps or damage repairs will not be measured. No separate payment shall be made for shipping, handling, storage, protection, fabrication, securing pins or installation, the cost of which shall be included in the contract price for geogrid.

**S-240.05--Basis of Payment.** Geogrid, measured as prescribed above, will be paid for at the contract unit price per square yard, which price shall be full compensation for furnishing and placing the geogrid, pins, lapping, joints, repairs, maintaining the geogrid until covered, and satisfactorily completing the work.

Payment will be made under:

**S-240-A:** Geogrid, Type \_\_\_\_\_ - per square yard

**Sections S-241 thru S-299 - Blank.**

<u>Section</u>	<u>Page</u>
S-300 - SUBBASES AND BASES	3-1
S-301 - thru S-303 - Blank	3-1
S-304 - GRANULAR COURSES	3-2
S-305 - and S-306 - Blank	3-7
S-307 - LIME TREATED COURSES	3-8
S-308 - PORTLAND CEMENT TREATED COURSES	3-19
S-309 - Blank	3-30
S-310 - MECHANICALLY STABILIZED COURSES	3-31
S-311 - LIME-FLY ASH TREATED COURSES	3-37
S-312 - thru S-319 - Blank	3-41
S-320 - SHOULDERS	3-42
S-321 - thru S-399 - Blank	3-44



The sections in the S-300 series include the specification requirements for subbases, bases, shoulders, and other work closely related to the construction of the pavement foundation and shoulders. Bituminous base courses shall be constructed as specified in S-400.

The term "course" used in this series of sections shall be understood to mean a structural component of specified thickness. A course may consist of one or more layers.

Shoulder courses shown on the plans to be constructed separately from subbase or base courses shall be performed in accordance with the provisions and requirements of S-320.

**Sections S-301 thru S-303 - Blank.**

**S-304.01--Description.** This work shall consist of furnishing granular materials and the construction of one or more courses of subbase, base, shoulders, or other required construction on a prepared foundation in reasonably close conformity with the lines, grades, and cross sections shown on the plans or established by the Engineer.

### **MATERIALS**

**S-304.02--Material Requirements.** Unless otherwise specified, materials used on this work shall conform to the requirements of S-703.07.

General conditions governing the use of materials shall be as set out under S-106.

### **CONSTRUCTION REQUIREMENTS**

**S-304.03--Equipment.** When measurement for payment is to be made by the ton, the Contractor shall use approved platform scales capable of weighing the entire loaded vehicle. Scales and their use shall be in accordance with the requirements set out in S-401.03.2.1.11, except they shall be installed at an approved location on or near the project.

Rollers shall be of sufficient number, type, size, and weight to accomplish the required compaction.

Watering equipment shall be pressurized, have spray bars with suitable nozzle openings, and have controls for applying varying quantities of water.

### **S-304.04--Production of Materials.**

**S-304.04.1--General.** If payment is to be made from cross section (FM) measurements, the Contractor shall not begin excavation in a pit until after the Engineer has taken the necessary cross sections. The Contractor shall be fully responsible for all material in the pit and shall protect the material from use or disposal for any reason other than for work included in the contract. He shall make good to the satisfaction of the Board of Supervisors and State Aid Engineer for all loss or unauthorized use of material.

Prior to beginning mining operations, all necessary clearing and grubbing and stripping of the pit area shall have been performed to the satisfaction of the Engineer.



**S-304.04.2--Mining and Mixing.** Mining and mixing shall be carried out so that all material meets the specified requirements for gradation, liquid limit, and plasticity index.

Mining and mixing shall be begun by opening the deposit in a manner that will immediately expose the full face of the material. Except as otherwise permitted herein, mining and mixing shall ordinarily consist of a combination of excavating and mixing the material in such a manner that the material meets the specified requirements.

All pit operations shall be confined to daylight hours, except when otherwise permitted under S-108.04.

Inspection of material as mined, mixed, and loaded from the pit will be made, and all obviously unsatisfactory material will be rejected. However, inspection or permission by the Engineer to produce material from any portion of a deposit will not relieve the Contractor of his responsibility to produce a satisfactory blend of material meeting the specified requirements.

When the Contractor elects, with the authorization of the Engineer, to combine two or more materials or to process a single material to provide that specified, all combining or processing shall be performed at the Contractor's expense. The sampling and testing and the cost thereof to control the necessary proportioning and processing will be the responsibility of the Contractor.

**S-304.05--Preparation of Grade.** The foundation on which granular material is to be placed shall be prepared as set out in S-205. A section of prepared roadbed of sufficient length to allow time for inspection, test, necessary corrections, and approval shall be maintained at all times ahead of placing material.

**S-304.06--Placing of Materials.** The Contractor shall be responsible for furnishing a material that meets the requirements of the contract and in such quantity to produce the specified compacted thicknesses. All material placed in excess of the tolerances allowed (See S-304.08.1) shall be removed and placed at other approved locations, or removed and hauled off the project without compensation.

If the compacted thickness of a course is to be more than eight inches, the course shall be constructed in two or more layers of approximately equal thickness, and the compacted thickness of a single layer shall not exceed eight inches.

No granular materials shall be placed while frozen or placed on frozen materials.

When the Engineer determines that in-place material, including the top portion of the design soil, is wet to the degree that there is a possibility of rutting, deforming, or displacing the underlying material, the hauling operation shall be suspended.

The Contractor shall produce such material as is necessary to correct any deficiencies in gradation, liquid limit and plasticity index and shall reprocess as necessary to make such corrections or shall remove and replace, without additional compensation, any deficient material placed in the work. In all cases of correcting deficiencies on the roadbed, the Contractor shall be fully responsible for any damage to the underlying course(s) and other work.

**S-304.07--Blending.** As soon as practicable after the material has been initially shaped, the entire volume of material for the course or layer being placed shall be processed and blended by blading in such a manner and as many times as necessary to produce a course visually uniform in gradation, color, liquid limit, and plastic limit. Care shall be exercised during the blending process to prevent contamination with underlying material. The Contractor shall be fully responsible for damage to or contamination with underlying or other unlike material and shall make the corrections deemed necessary without additional compensation. The requirement for blending will not be waived by the Engineer, and required mixing or further processing under subsequent items of work will not relieve the Contractor from the complete performance of blending as specified in this subsection, except for shoulders as follows:

When granular material is required to be placed adjacent to pavement in place, blending in place will not be required. Blending shall be performed to the satisfaction of the Engineer prior to placement of the material on shoulders.

**S-304.08--Shaping, Compacting, and Finishing.** Each course or layer of material shall be shaped to the required section, watered or aerated as necessary to produce the required moisture content, and compacted. Throughout the compaction operation, the shape of the course or layer shall be maintained by blading and rolling so that the aggregates are uniformly distributed and firmly keyed.

Shaping and compaction shall be carried out in a manner that will prevent lamination and shall continue until the entire depth and width of the course or layer has reached the required density. Surface compaction and finishing shall be performed so as to produce a smooth, closely knit surface that is free from lamination, cracks, ridges or loose material. The finished surface shall conform (within allowable tolerances) to the required section and established lines and grades.

Prior to subsequent construction or final acceptance all irregularities, depressions, soft spots, and other deficiencies found by the Engineer shall be corrected to meet the requirements of these specifications without additional compensation.

If the mixture contains plus No. 4 aggregate and the course is to serve as a base for bituminous pavement, after compaction and finishing at least one complete coverage shall be made with a steel wheel tandem roller. The resulting surface shall be sprinkled as necessary to maintain the required moisture content and shall be thoroughly compacted and sealed with a pneumatic roller.

Crushed stone shall be placed in layers not to exceed four (4) inches compacted depth and shall conform to the density requirements stated.

In addition to the requirements for density and correction of deficiencies, the Contractor shall be responsible for constructing and maintaining a course which will remain firm and stable under construction equipment and other traffic to which the course will be subjected.

Density tests will be performed in accordance with the methods as provided in S-700.03 and S-700.04.

Determination of acceptance of compaction of granular courses for required density will be performed on a lot to lot basis. Each lot will be each 2,500 linear feet per layer placed. At the discretion of the Engineer, a residual portion of a lot completed during a day's operation may be considered as a separate lot or may be included in the previous or the subsequent lot, except that any day's operation of less than one full lot will be considered a lot.

The lot will be divided into five approximately equal sublots with one density test taken at random in each subplot. The individual tests and the average of the five tests shall equal or exceed the values as shown in the table below.

Granular Material (Class)	Lot Average	Individual Test
7,8,9 or 10	97.0	93.0
5 or 6	99.0	95.0
3 or 4	100.0	96.0
1 or 2	102.0	98.0
Crushed Stone Courses	99.0	95.0

When pavement is not required, the required density for the top course will be as shown in the table below.

Granular Material (Class)	Lot Average	Individual Test
10	94.0	90.0
7,8 or 9	95.0	91.0
5 or 6	96.0	92.0
3 or 4	97.0	93.0
1 or 2	98.0	94.0
Crushed Stone Courses	96.0	92.0

No density tests will be required for granular or crushed stone courses used for temporary work such as maintaining temporary ramps and driveways.

A finished course shall be continually maintained until a subsequent course is placed thereon or the work is released from maintenance.

**S-304.08.1--Tolerances for Subbase & Base Course:** It shall be understood that although certain tolerances in grade, cross section, and density are allowable under the specifications, it shall be the Contractor's responsibility to prepare the surface of all in-grade courses to the degree of true grade and cross section and to the density and stability necessary to insure his ability to construct subsequent courses to the specified requirements for surface, thickness, and compaction. It is essential in pavement structure construction that the degree of accuracy must be increased for each succeeding course in order that the final surface requirements can be met and the thickness of each course will be within design tolerances. It shall be the Contractor's responsibility to construct each course to the degree of accuracy, maximum allowable tolerances notwithstanding, necessary to insure meeting final requirements.

No vertical tolerances will be allowed which will pond water. Otherwise, allowable tolerances will be as follows:

#### Tolerances from Design Grade

<u>Subbase</u>		
(a)	Where the subbase is not to be treated in place inch	$\pm 1/2$
(b)	Where the subbase is to be either mechanically stabilized or treated before stabilization or treatment	$\pm 1$ inch
(c)	After Treatment inch	$\pm 1/2$
<u>Base</u>		
(a)	Where the base is not to be treated inch	$\pm 3/8$
(b)	Where the base is to be either mechanically stabilized or treated before stabilization or treatment inch	$\pm 1/2$
(c)	After Treatment	$\pm 3/8$ inch

**COMPENSATION**

**S-304.09--Method of Measurement.** When the method of measurement is by the ton, measurement will be made on the dry unit weight basis. The moisture determination for computing the dry unit weight will be made in accordance with the methods as provided in S-700.03 once a day and as many additional times as the Engineer deems necessary. Accepted quantities of granular material will be measured by the ton or cubic yard, FM or LVM, as indicated in the bid schedule of the contract. Water necessary for processing granular material will not be measured for separate payment.

**S-304.10--Basis of Payment.** Accepted quantities of granular material will be paid for at the contract unit price per unit specified in the bid schedule of the contract, which shall be full compensation for completing the work specified.

Payment will be made under:

**S-304-A:** Granular Material \_\_\_\_\_, (Class \_\_\_\_, Group \_\_\_\_) - per cubic yard  
(FM or LVM)

**S-304-B:** Granular Material, (Class \_\_\_\_, Group \_\_\_\_) - per ton

**S-304-C:** Crushed Stone \_\_\_\_\_, \_\_\_\_\_ - per cubic yard  
(Size) (FM or LVM)

**S-304-D:** Crushed Stone - per ton

**Sections S-305 and S-306 - Blank.**

**S-307.01--Description.** This work shall consist of constructing one or more courses of a mixture of soil, hydrated lime, and water or a mixture of soil and hydrated lime slurry, all in accordance with these specifications and in reasonably close conformity with the lines, grades, thicknesses, and typical cross sections shown on the plans or established by the Engineer. When lime slurry is used, the Contractor shall mix hydrated lime with water to produce lime slurry or, at his option, produce lime slurry at the job site by the use of equipment specifically manufactured for the slaking of quick lime.

The use of quick lime by the dry application method will not be allowed unless the lime meets the requirements of S-714.03.3.2 for Dry Quick Lime.

The work shall include preparation of the roadbed, incorporation of lime or lime slurry, and processing in accordance with one of the following methods:

Class A lime treatment shall consist of spreading and incorporating the specified percentage of lime in two increments in the following sequence: spreading the first increment, initial mixing, mellowing, spreading the second increment, final mixing, compacting, and finishing.

Class B lime treatment shall consist of spreading the specified percentage of lime, initial mixing, mellowing, final mixing, compacting, and finishing.

Class C lime treatment shall consist of spreading the specified percentage of lime, mixing, compacting, and finishing.

The soil profile is normally not available before a project is advertised and it is not possible to determine the precise class of lime treatment required. Design considerations, therefore, sometimes necessitate changing the class(es) of lime treatment in order to obtain the contemplated structural qualities without unnecessary cost.

The Board and the State Aid Engineer reserve the right to modify by CCR the class of treatment or to eliminate lime treatment from certain sections or to add other sections for lime treatment depending on the results of soil tests, in conformance with S-100.

## MATERIALS

### S-307.02--Material Requirements.

**S-307.02.1--Materials to be Treated.** The material to be treated shall consist of existing roadbed material or material added as directed. Particles of aggregate retained on a three inch sieve and deleterious substances such as roots, stumps, grass, turf, and other vegetable matter shall be removed from the soil. Material considered by the Engineer to be unsuitable for stabilization shall be removed and replaced with suitable material.

**S-307.02.2--Water.** Water used in this construction shall meet the requirements of S-714.01.3.

**S-307.02.3--Lime.** Lime shall meet the requirements of S-714.03.

Lime shall be stored and handled in closed, weather-proof containers until distribution on the section of road being processed. If local storage is provided, lime shall be used only from approved storage facilities and shall meet these requirements at the time of use.

The Contractor is reminded of the highly caustic characteristic of quick lime and shall instruct employees as to preventive and protective measures to take prior to their working with quick lime. Further, the Contractor shall take all precautions necessary to prevent injury to persons not in his employ and to livestock. Quick lime which is spilled or deposited at places other than on areas designated to be treated shall be immediately picked up, buried, or slaked by wetting to eliminate the hazard.

**S-307.02.4--Curing Seal.** Curing seal shall be Emulsified Asphalt, Grade EA-1, SS-1, CMS-2h, or MS-2h meeting the applicable requirements of S-702.

**S-307.03--Equipment.** The methods and equipment used in performing the work shall conform to the requirements of S-108.05. Equipment necessary for proper prosecution of the work shall be on the project and approved by the Engineer prior to its use.

When bulk lime is used, and application of lime is made from equipment other than the delivery transport, batch-type or platform scales shall be provided. Batch type scales shall meet the requirements set out for scales in MDOT Specifications Subsection 501.03.2.3. Platform scales shall meet the requirements of S-401.03.2.1.11. All scales shall be located at approved locations on or near the project.

When bulk lime is used, the Contractor shall provide approved mechanical spreader(s) having adjustable strike-off gate(s), or other approved spreading equipment constructed so as to provide positive control of the spread. Approval of a spreader will be contingent upon its known or demonstrated ability to make distribution of lime within the tolerances allowable.

Mixing and scarifying equipment shall be capable of positive depth control. Mixing shall be performed with approved rotary type mixers or other approved equipment.

Rollers shall be of sufficient number, type, size, and weight to accomplish the required compaction.

The Contractor may use approved alternate equipment provided it produces work meeting the requirements of these specifications.

### **CONSTRUCTION REQUIREMENTS**

**S-307.04--General.** Quantities and percentages of lime shown on the plans and proposal are estimated. The actual application rate will be established from tests made just prior to beginning treatment. The Contractor is hereby advised that the estimated contract quantity of lime is based on application rates of hydrated lime.

It is necessary that lime treated materials be kept moist at all times. It shall be the Contractor's responsibility to provide sufficient equipment and keep all partially constructed or completed lime stabilized layers sufficiently and continually moist until a succeeding layer has been placed thereon or until release of maintenance of the project.

The first section of each mixing operation, both initial and final, will serve as a test section. The length of the test section (not less than three hundred fifty (350) linear feet nor more than five hundred (500) linear feet for the designated width) will be determined by the capabilities of the equipment provided to perform the work. The Engineer and the Contractor will evaluate the results of the test section in relation to contract requirements. In case the Engineer determines the work is not satisfactory, the Contractor shall revise his procedures and augment or replace equipment as necessary to assure work is completed in accordance with the contract and shall correct any deficient work at no additional cost to the Project.

Also within the test section and only when the dry-application method of quicklime is used, a sample of the soil-lime-water mixture shall be taken after the completion of the mixing operation. This sample shall be taken, by the Contractor, to an independent testing laboratory to determine, using the X-ray Diffraction Test or the Titration Analysis Test, the percent of hydration. After the completion of the test section, the Contractor shall not continue operations until the results of the test sample have been determined. The Contractor shall provide the Engineer with three copies of a certified test report showing that the non-hydrated content of the sample has not exceeded one percent (1.0%) of the total mix. Should the sample not meet the hydration requirements, the Contractor shall re-mix the section and add sufficient water until satisfactory results are achieved. All testing costs associated with determining the hydration efficiency of the sample(s) will be at no additional cost to the Project. The Engineer reserves the right to make hydration verification checks of the soil-lime-water mixture at any time.



**S-307.05--Preparation of Grade.** Before treatment, the roadbed shall be prepared in accordance with the requirements of S-205 (Reference is made to Figure 1, S-100).

Prior to the application of dry hydrated lime, a light windrow shall be bladed along the edges of the area to be treated, or the surface on which the lime is to be applied shall be scarified to retain the spread.

Prior to the application of slurry, the full width of the area shall be scarified or partially pulverized to the depth necessary to retain the lime slurry until it has been incorporated.

The depth of scarification shall be carefully controlled so that the surface of the roadbed below the scarified material will remain undisturbed and conform as closely as possible to the established cross section.

**S-307.06--Application of Lime.** The rate of application of lime shall be as specified. The first application for Class A treatment shall not be made after October 15, and no lime shall be applied between November 1 and March 1 without written authorization from the State Aid Engineer.

Lime shall not be applied unless the temperature in the shade is at least 40°F and is expected to remain at least 40°F during the mixing period. In no case shall lime be applied on a frozen foundation.

Application of lime shall be accomplished by either an approved "dry application" or "slurry application" method.

The following guide lines will govern the acceptability of the method to be used:

**Dry Application.** Lime applied by this method shall be spread uniformly and shall be sprinkled with sufficient water to prevent loss of lime by wind. Spreading of lime when wind and weather conditions are unfavorable will not be permitted nor will spreading of lime by motor patrol be acceptable.

The Engineer reserves the right to check, at any time, the dispersion of quick lime dust in the atmosphere. At no time shall the atmosphere dispersion of quick lime dust exceed a rate of 30,000  $\mu\text{g}/\text{m}^3$ , measured at a distance of 100 feet.

**Slurry Application.** Lime applied by this method shall be mixed with water in approved agitation equipment and applied to the roadbed as a thin water suspension or slurry. The distributing equipment shall be equipped to provide continuous agitation of the slurry until applied on the roadbed. The proportion of lime shall be such that the "Dry Solids Content" shall be at least thirty (30) percent by weight.

The distribution of lime at the rate specified shall be attained by one or more passes over a measured section until the specified percentage of lime has been spread. After each successive pass, the material shall be incorporated into the soil with the mixing equipment. Additional water, if necessary, shall be added and mixed into the mass to hasten mellowing.

Payment will not be made for lime that has been spread and exposed for a period of six hours or more before mixing. Such areas shall be treated again with the full required rate of application.

Additional lime shall be added at the Contractor's expense to all sections on which excessive loss has occurred due to washing or blowing.

The quantity of lime applied on a section shall be spread uniformly and shall not vary more than plus or minus five percent of the quantity ordered. No payment will be made for lime application exceeding the five percent plus tolerance. When the quantity applied is deficient by more than five percent, additional lime shall be applied prior to mixing.

### **S-307.07--Mixing.**

**S-307.07.1--Initial Mixing.** For Class A and Class B treatments, the lime and water shall be incorporated uniformly into the soil. The mixing and watering operation shall be continued until a homogeneous mixture that will pass a three inch sieve is obtained. After satisfactory mixing is obtained, the layer shall be reshaped to line, grade, and section and sealed with a light roller no later than the next day following mixing. The sealed mixture shall then be left to mellow for the period specified in the lime mix design furnished by the MDOT Central Laboratory or other approved laboratory. The mellowing period will be measured in degree days. This period will not be less than five (5) calendar days nor more than twenty (20) calendar days. The temperature to be used to determine the degree days mellowing period will be the average of the high and low temperatures for each day of the mellowing period. In the event the average is 40°F or less, that day will not be used in computing the degree days mellowing period. The recommended degree days for the mellowing period may be reduced by the Engineer provided pulverization during final mixing is documented by sieve analysis.

During the mellowing period the partially treated course or layer shall be kept moist by sprinkling. All sections on which the surface becomes dry during the mellowing period shall be reprocessed to the satisfaction of the Engineer or reconstructed in accordance with the specifications.

For Class C treatment, the lime and water shall be incorporated uniformly into the soil. The mixing and water application shall be continued until a homogeneous mixture of which one hundred (100) percent of the material by dry weight, exclusive of gravel and stone, will pass a one inch sieve and sixty (60) percent will pass a No. 4 sieve. At the completion of moist mixing and during the compaction operations, the percentage of moisture shall be that necessary to obtain the required density. There will be no mellowing period, and compaction shall begin immediately. The mixing, water application, and final compaction shall be completed during the same work day.

**S-307.07.2--Final Mixing.** After the required mellowing period (Class A and B), the layer shall be scarified, and in the case of Class A treatment the second application of lime added.

The layer shall then be remixed as prescribed in the initial mixing operations. Mixing shall continue until one hundred (100) percent of material by dry weight, exclusive of gravel and stone, will pass a one inch sieve and sixty (60) percent will pass a No. 4 sieve. At the end of mixing and during compaction, the moisture in the mixture shall be that necessary to obtain the required density.

**S-307.07.3--Thickness and Width Requirements.** For the purpose of determining reasonable conformity with the designated thickness of a course, it shall be understood that the depth of a course shall not vary from the designated thickness by more than plus or minus one inch. All sections not in reasonably close conformity because of deficient thickness shall be reprocessed to meet specification requirements. All sections not in reasonably close conformity because of excess thickness shall have additional lime applied and shall be reprocessed to meet specification requirements at no additional cost to the Project.

For the purpose of determining reasonable conformity with the designated width of a course, it shall be understood that the width of a course shall not vary from the designated edge lines by more than plus or minus three inches.

**S-307.08--Compaction.** Compaction of the mixture shall begin immediately after the required mixing operation has been completed.

Compaction shall be completed during same day it was begun and shall provide uniform and continuous compaction from bottom to top of the layer. The mixture shall be aerated or watered as necessary to obtain the moisture content required for the required density.

Throughout the entire compaction operation, depression, defective areas, or soft spots which develop shall be corrected immediately by scarifying the area, adding lime when required, or removing the material, and reshaping and compacting in accordance with these specifications and at the Contractor's expense.

Density tests will be performed in accordance with the methods as provided in S-700.03 and S-700.04.

Determination of acceptance of compaction of Classes A, B, and C lime treated design soil will be performed on a lot to lot basis. Each lot will be 2,500 linear feet per layer placed. At the discretion of the Engineer, a residual portion of a lot completed during a day's operation may be considered as a separate lot or may be included in the previous or subsequent lot, except that any day's operation of less than one full lot will be considered a lot.

The lot will be divided into five approximately equal sublots with one density test taken at random in each subplot. The average of the five density tests shall equal or exceed 95.0 percent with no single density test below 91.0 percent. Sublots with a density below 91.0 percent shall be corrected at no additional cost to the Project and retested for acceptance.

**S-307.09--Finishing, Curing, Protection, and Maintaining.** The surface of the layer shall be smooth and conform to the lines, grades, and typical cross section(s) shown on the plans or established by the Engineer. The surface tolerances will meet the requirements of S-304.08.1.

The surface of the lime treated course shall be kept moist and otherwise satisfactorily maintained until placement of the subsequent course or layer. If the next course is to be granular material, the first layer placed shall be at least four inches in thickness. During placement of the subsequent course or layer, the least possible hauling will be permitted over the unprotected lime treated course. Except as provided in the following paragraph, the subsequent layer or course shall be placed and compacted within two days after the lime treated course has been finished.

At his option, the Contractor may defer placement of the subsequent course or layer for up to twenty-one (21) days by placing a bituminous curing seal over the lime treated course within two days after finishing the course. The lime treated course shall be kept moist until application of the curing seal. When a curing seal is used, the emulsified asphalt shall be applied at the consistency specified in S-702 without further dilution. The rate of application shall be within the limits of 0.10 to 0.25 gallon per square yard as directed by the Engineer.

Should the Contractor fail to cover a lime treated course with the curing seal or subsequent course within the times specified, the Engineer will suspend all other work and withhold payment of the current estimate(s) until all damage resulting therefrom is repaired and the treated course is covered with the curing seal or the subsequent course, as the case may be.

A subsequent course shall not be placed on the sealed course for at least seven (7) calendar days. If local traffic is permitted to use the roadway during this seven day period then load restrictions should be imposed on the vehicles. When necessary for the maintenance of vehicular traffic, the Contractor shall furnish and apply blotter material in accordance with S-408.03 and S-408.08. Maintenance of the curing seal shall be in accordance with the provisions of S-408.09.

All damage, as determined by the Engineer, resulting from the Contractor's failure to protect and cure the treated course as specified herein or from freezing that may occur in a treated course prior to being covered by the next course shall be corrected by reprocessing the course with Class C treatment at the Contractor's expense. The Contractor shall add the quantity of lime necessary to restore the CBR of the damaged material to that shown on the mix design. In no case shall the quantity of added lime be less than two percent by weight.

### COMPENSATION

**S-307.10--Method of Measurement.** Accepted soil-lime-water mixing will be measured by the square yard, complete in place, for each course designated on the plans.

If a change in the class of treatment is made, as provided in S-307.01, each class of treatment constructed will be measured separately.

Lime incorporated in accepted treatment will be measured by the ton in accordance with provisions of S-109. Lime in excess of the tolerance allowable and all lime required to be furnished by the Contractor at no additional cost to the Project will be deducted from measured quantities.

The basis of pay for jobsite slaked lime slurry shall be the "calculated method" using the certified lime purity for each truckload as follows:

$$\text{Pure Quick lime (Ca O) x 1.32 = Hydrated Lime (Ca (OH)}_2\text{)}$$

$$\text{Quick Lime delivered x \% purity x 1.32 = A}$$

$$\text{Quick Lime delivered x \% inert material x 1.0 = B}$$

$$\text{A + B = Total Hydrated Lime produced (Pay Quantity)}$$

The basis of pay for quick lime by the dry application method shall be the "calculated method" using the certified lime purity for each truckload as follows:

$$\text{Pure Quick Lime (Ca O)} \times 1.32 = \text{Hydrated Lime (Ca (OH)}_2$$

$$\text{Quick Lime delivered} \times \% \text{ purity} \times 1.32 = A$$

$$\text{Quick Lime delivered} \times \% \text{ inert material} \times 1.0 = B$$

$$A + B = \text{Total Hydrated Lime produced (Pay Quantity)}$$

Water and curing seal will not be measured for separate payment.

**S-307.11-Basis of Payment.** Accepted quantities of soil-lime-water mixing and lime measured as provided in S-307.10 will be paid for as follows:

Soil-lime-water mixing of the class(es) specified or ordered will be paid for at the contract unit price, or adjusted unit price as provided herein, per square yard.

Quantities of soil-lime-water mixing changed as ordered will be paid for at the contract unit price for soil-lime-water mixing, plus or minus as applicable, the amount indicated in the following schedule:

**SCHEDULE**

Price Adjustment Due to Change in Class of Lime Treatment			
Plan Depth	Class Bid	Class Ordered	Adjusted Price Equals
6 "	A	B	Price Bid Minus \$0.05 per square yard
	A	C	Price Bid Minus \$0.10 per square yard
	B	A	Price Bid Plus \$0.05 per square yard
	B	C	Price Bid Minus \$0.05 per square yard
	C	A	Price Bid Plus \$0.10 per square yard
	C	B	Price Bid Plus \$0.05 per square yard
8"	A	B	Price Bid Minus \$0.10 per square yard
	A	C	Price Bid Minus \$0.15 per square yard
	B	A	Price Bid Plus \$0.10 per square yard
	B	C	Price Bid Minus \$0.05 per square yard
	C	A	Price Bid Plus \$0.15 per square yard
	C	B	Price Bid Plus \$0.05 per square yard

If 10 inch course is designated, use MDOT Specifications.

Lime will be paid for at the contract unit price per ton.

Payment for removal and disposal of unsuitable material will be made under other provisions of the contract.

Prices thus paid shall be full compensation for completing the work specified.

Payment will be made under:

**S-307-A:** \_\_\_” Soil-Lime-Water Mixing (Class A) - per square yard

**S-307-B:** \_\_\_” Soil-Lime-Water Mixing (Class B) - per square yard

**S-307-C:** \_\_\_” Soil-Lime-Water Mixing (Class C) - per square yard

**S-307-D:** Lime - per ton



**S-308.01--Description.** This work shall consist of constructing one or more courses of a mixture of cement, soil or soil aggregate, and water in accordance with these specifications and in reasonably close conformity with the lines, grades, and cross sections shown on the plans or established by the Engineer.

### **MATERIALS**

#### **S-308.02--Material Requirements.**

**S-308.02.1--Materials to be Treated.** The materials to be treated shall consist of materials in place or placed under this contract.

**S-308.02.2--Water.** Water shall conform to the requirements of S-714.01.3

**S-308.02.3--Portland Cement.** Cement shall conform to the requirements of S-701.

Cement shall be stored and handled in closed, weatherproof containers until distribution to the section of road being processed. If storage bins are used, they shall be completely enclosed.

When bulk cement is used, the Contractor shall provide means suitable to the Engineer for applying. The Engineer shall weigh shipments at random for verification of bulk cement quantities.

When bag cement is furnished, the bag shall bear the manufacturer's certified weight. Bags varying more than five percent from the certified weight will be rejected, and the average weight of bags in any shipment, determined by weighing 50 bags taken at random, shall not be less than the certified weight.

**S-308.02.4--Curing Seals.** Curing Seals shall meet the requirements of S-307.02.4.

#### **S-308.03--Equipment.**

**S-308.03.1--General.** Equipment necessary for proper prosecution of work shall be on the project and approved by the Engineer prior to its use.

When bulk cement is used and application of cement is made from equipment other than the delivery transport, batch-type or platform scales shall be provided. Batch type scales shall meet the requirements of MDOT Subsection 501.03.2.3. Platform scales shall meet the requirements of S-401.03.2.1.11. All scales shall be located at approved locations on or near the project.

Approval of cement spreaders will be contingent upon their known or demonstrated ability to make distribution of cement within allowable tolerances.

Watering equipment shall be pressurized, have one or more spray bars with suitable nozzle openings, and have positive controls for applying varying quantities of water.

Mixing shall be performed with multiple pass mixers, single pass mixers, traveling mixing plants, or central mixing plants, as specified in the contract.

Mixing and scarifying equipment for the road mix methods shall be capable of positive depth control.

Rollers shall be of sufficient number, type, size, and weight to accomplish the required compaction.

Leakage of water, oil, grease, or other liquids from equipment shall be immediately corrected, or the leaking equipment removed from the work and replaced with satisfactory equipment.

**S-308.03.2--Multiple Pass Mixers.** Multiple pass mixers shall be the rotary-type with sufficient tines and so constructed and operable as to obtain by multiple passes uniform mixture of the cement, soil-aggregate, and water for the full depth of the course.

**S-308.03.3--Single Pass Mixers.** Single pass mixers shall be the pugmill type so constructed and operable as to measure the required quantity of water through a pressurized spray and obtain by a single pass a uniform mixture of the cement, soil or soil-aggregate, and water for the full depth of the course.

**S-308.03.4--Traveling Plant Mixers.** Traveling mixing plants shall be either of the type which will pulverize the material to be treated and mix it and cement with the proper quantity of water without picking the materials up from the roadway, or of the pugmill type which elevates the materials into a pugmill for mixing. The plant shall be equipped with a device which will accurately control and measure the quantity of water used. Worn scarifying and mixing parts shall be replaced, and extra parts shall be available for replacements.

**S-308.03.5--Central Plant Mixers.** Central mixing plants shall be either the batch type using revolving blade or rotary drum mixers or the continuous mixing type. The cement, soil or soil-aggregate, and water may be proportioned either by weight or by volume. There shall be means by which the Engineer can readily verify the proportions in each batch or the rate of flow for continuous mixing.

The charge and mixing time in a batch mixer, or the rate of feed to a continuous mixer, shall be such as to obtain complete mixing of all the material. Dead areas in the mixer, in which the material does not move or is not sufficiently agitated, shall be corrected. The plant shall deliver a uniform mixture meeting all specified requirements.

### **CONSTRUCTION REQUIREMENTS**

**S-308.04--General.** The intent of these specifications is to provide for a cement treated course of designated thickness consisting of a uniform mixture of cement, soil or soil-aggregate, and water; constructed at the required moisture content; to the required density; free of laminations, construction cracks, ridges, or loose material; and with a smooth, closely knit surface meeting the requirements of these specifications.

If the thickness of a course is designated to be more than eight inches, the course shall be constructed in two or more layers of approximately equal thickness. The compacted thickness of a single layer shall not exceed eight inches.

Prior to incorporating cement, the base or subbase course will be graded to conform to the lines and grades furnished by the Engineer.

Immediately prior to placement of a course to be cement treated on an in-place cement treated course, the surface of the in-place course shall be thoroughly moistened.

Except as necessary to provide the required curing and maintenance of traffic, all equipment and traffic shall be kept off each completed cement treated course until it is thoroughly cured. Unless otherwise specified, the curing period shall be seven days exclusive of days during which the temperature falls below 35°F.

Prior to joining a previous day's work, or work more than two hours old, a vertical construction joint, normal to the center-line of the roadbed, shall be made in the old work. The joint shall be moistened if dry. Additional processing shall not be started until the construction joint has been approved by the Engineer.

When vertical longitudinal joints are specified or permitted, the joints shall be constructed parallel to the centerline by cutting into the existing edge for a sufficient distance to provide a vertical face for the depth of the course. The material cut away may be disposed of by spreading in a thin layer on the adjacent lane to be constructed, or otherwise disposed of in a satisfactory manner. If dry, cut joints shall be moistened immediately in advance of placing fresh mixture adjacent to them.

The first section of each cement treated course constructed will serve as a test section. The length of the test section (not less than three hundred fifty (350) linear feet nor more than five hundred (500) linear feet for the designated width) will be determined by the capability of the equipment provided to perform the work. The Engineer and the Contractor will evaluate results of the test section in relation to contract requirements.

In case the Engineer determines the work is not satisfactory, the Contractor shall revise his procedures and augment or replace equipment as necessary to assure work completed in accordance with the contract, and shall correct all deficient work at no additional cost to the County.

**S-308.05--Road-Mix Method.** When the road-mix method is used, no hauling of materials for a subsequent course will be permitted directly on a completed cement-treated course. Materials for a higher course shall be kept bladed down as it is placed, and hauled over with truck traffic being distributed over its entire width.

Where reconstruction is required, it shall be for the full depth and width of the deficient section. The adding of a thin layer or strip of cement-treated material will not be permitted. All sections to be reconstructed later than the two-hour period allowed for initial compaction shall have additional cement. When reconstruction is to be performed within forty-eight (48) hours after the initial application of cement, fifty (50) percent of the original quantity of cement shall be added. When reconstruction is to be later than forty-eight (48) hours after the initial application of cement, an engineering study will be made, and the Engineer will specify the additional quantity of cement to be added, or the Engineer may require the total removal of the deficient work. If removal is required, a course meeting the requirements of the contract shall be constructed with new materials.

In all cases where reconstruction is performed by the addition of cement, the cement, in-place materials, and water shall be thoroughly mixed, processed, compacted, and finished in accordance with the requirements of the contract.

Where deficient work is removed, the removal and disposal shall be performed in a manner satisfactory to the Engineer, and all materials shall be replaced and a new course constructed in accordance with the requirements of the contract.

The furnishing of all materials for and all reconstruction shall be performed by the Contractor at no additional cost to the project.

**S-308.06--Central Plant Mix Method.** When the central plant mix method is used, material for a higher course may be hauled directly on a completed and properly cured cement treated course for the minimum distance necessary. The Contractor shall be fully responsible for all damages to the course.

Prior to placement of a course processed by the plant mix method, the Contractor shall have made satisfactory provisions for completing the section to specified requirements. To comply with these requirements, the Contractor shall, if necessary, use materials(s) specified for contiguous shoulder construction.

The mixture shall be hauled to the roadway in trucks equipped with protective covers. The mixture shall be uniformly placed on a moistened foundation by full-width spreader, or partial-width spreaders working in echelon and spaced close enough together to place the entire course in one operation. The elapsed time between the start of moist mixing and the start of compaction on the roadway shall not exceed sixty (60) minutes. The elapsed time between placement of cement treated material in adjacent lanes shall not exceed thirty (30) minutes, except where longitudinal construction joints are specified, or when joints are permitted by the Engineer in case of emergency. In the latter case longitudinal joints conforming to the requirements of these specifications will be permitted only to allow placement of material in transit at the time of the emergency.

The material shall be placed, shaped, and compacted so that the completed course will be uniform, smooth, and conform to all of the requirements specified.

Dumping of the mixture in piles or windrows and spreading with a motor grader or similar equipment will not be permitted except in areas where such spreading is reasonable, as in the case of small areas inaccessible to mechanical spreaders.

In all cases where reconstruction is required, the deficient work shall be removed, disposed of, and replaced with material's meeting the requirements of these specifications. Reconstruction shall be for the full depth and width of the deficient section.

**S-308.07--Preparation of Grade.** Prior to construction or reconstruction, the foundation shall be prepared in accordance with the requirements of S-205. The tolerance from design grade immediately prior to spreading cement shall be plus or minus one-half ( $\pm 1/2$ ) inch for bases.

**S-308.08--Preparation of Materials.** Particles of aggregates larger than those passing a three inch sieve and deleterious substances, such as roots, sticks, grass turfs, or other vegetable matter shall be removed.

**S-308.09--Application of Cement.**

**S-308.09.1--General.** The percentages of cement shown on the plans are based on preliminary soil investigation and are approximate.

Before construction is started, the MDOT Central Laboratory or other approved Laboratory will make the necessary tests and recommend the percentages of cement required. The quantity of cement spread on a section or added through a central plant shall not vary more than five percent of the quantity ordered. When the quantity spread is deficient by more than five percent, an additional application of cement shall be uniformly spread over the entire section to correct the deficiency prior to mixing operation. Cement (including that applied to correct deficiency) in excess of the allowable plus tolerance will be deducted from measured quantities.

When the quantity of cement added through a central plant is deficient by more than the allowable tolerance, all mixtures produced with deficient cement will be considered unacceptable.

When the quantity of cement added through a central plant is in excess of the allowable tolerance, the excess will be computed by the Engineer and deducted from measured quantities.

**S-308.09.2--Weather Limitations.** No cement or cement treated material shall be placed between October 1 and March 15, unless the following course is to be hot bituminous mix. If hot bituminous mix is the following course the season may be extended from March 15 to November 15 with prior written approval of the State Aid Engineer. Cement or cement treated material shall not be applied when the ambient air temperature is below 40°F nor when the Engineer determines, based on the latest information available from the National Weather Service, that probable freezing will occur within seven days in the area in which the project is located. No cement or cement treated material shall be placed on a frozen foundation, nor shall cement be mixed with frozen material.

**S-308.09.3--Road Mix Method.** After preparation of the grade, the required quantity of cement shall be spread uniformly over the grade. Cement lost or damaged from any cause shall be replaced without additional compensation before mixing is started.

The cement spreader shall be positioned by string lines or other approved methods during spreading to ensure proper application of cement. All cement deposited into the spreader shall be weighted so that the pay quantity and the rate of spread can be determined.

In small areas, bag distribution in an approved manner, will be permitted. When bag distribution is made, a spike-toothed harrow or other equipment, which will not drag or blade the cement out of desired position but will strike it off at a uniform height, may be used. A motor grader, or other blade-type equipment, shall not be used to spread the cement.

Except for final finishing, all processing shall be completed within three hours after spreading. Except by written permission of the Engineer, no cement shall be spread on an area which cannot be completely processed, including all final surface finishing, during the same day.

No cement shall be applied when the moisture content of the material to be processed exceeds the optimum for the soil-cement mixture by more than two percentage points. No cement shall be spread when free water is on the surface of the roadbed.

No equipment except that used in spreading or mixing shall be allowed to pass over the freshly spread cement until mixed with the material to be treated.

**S-308.09.4--Central Plant Mix Method.** The cement shall be uniformly metered into the soil or soil-aggregate in the specified proportions and at the time and in such a manner that the application of water will not cause formation of cement balls.

**S-308.10--Mixing.**

**S-308.10.1--General.** Unless otherwise indicated, cement treated materials may be processed by any one or combination of the mixing equipment described in S-308.03. Where the bid schedule indicates single pass mixers, traveling plant mixers or central plant mixers will also be permitted. Where the bid schedule indicates traveling plant mixers, central plant mixers will also be permitted.

Preliminary scarifying shall be carefully controlled and the undisturbed foundation shall have a crown conforming as nearly as practicable to that of the finished course. Subject to the moisture limitations prior to spreading cement (Reference S-308.09.3), soil to be processed may be prewetted prior to spreading cement. All additional water required to bring the section being processed to the required moisture content shall be applied within one hour after the beginning of mixing.

Mixing shall be carefully controlled so that the bottom of the course will conform as closely as possible to the design grade and cross section.

When the plans indicate multiple courses to be constructed, the material for each course shall be mixed separately. Multiple courses shall be constructed so that each course is in direct contact with the underlying course, and an unmixed cushion of material between layers will not be permitted.

Each increment of water added during mixing shall be incorporated into the mixture for the full depth, and no portion of the mixture shall remain undisturbed for more than thirty (30) minutes prior to compaction. Mixing and water application shall be continued as necessary to produce a completed mixture of uniform moisture content. Particular care shall be exercised to ensure satisfactory moisture distribution along the edges of the section, and to avoid the addition of excess water.

The soil-cement mixture for subbase and base construction shall be pulverized to the extent that 100% of the material (exclusive of gravel and stone) by dry weight will pass a one inch sieve and a minimum of 75% will pass a No. 4 sieve.

The soil-cement mixture for design soils shall be pulverized to the extent that 100% of the material (exclusive of gravel and stone) by dry weight will pass a one inch sieve and a minimum of 60% will pass No. 4 sieve.

When the uncompacted mixture is wetted by rain to the extent the average moisture content at the time for final compaction exceeds optimum by more than two percent, or if any of the operations after the start of mixing are interrupted continuously for more than thirty (30) minutes, the entire area affected shall be reconstructed in accordance with these specifications at no additional cost to the project.

#### **S-308.10.2--Roadmix Methods.**

**S-308.10.2.1--Multiple Pass Mixing.** After the cement has been spread, it shall be mixed with the material to be treated without the addition of water. Immediately after the preliminary mixing of cement and soil or soil-aggregate, water as necessary shall be applied in the quantity required and incorporated uniformly into the mixture for the full depth.

After the last increment of water has been applied, mixing shall continue as necessary until a uniform mixture of cement, soil or soil-aggregate, and water for the full depth of the course has been obtained.



**S-308.10.2.2--Single Pass Mixing.** After the cement has been spread, it shall be mixed by a mixer which applies water and mixes in one simultaneous and continuous operation. The mixer shall be operated at a speed that will produce a uniform mixture meeting all specified requirements for the full depth of the course.

**S-308.10.2.3--Traveling Plant Mixing.** After the cement has been spread, it shall be mixed with a traveling plant mixer that will apply the proper quantity of water and produce in one simultaneous and continuous operation a mixture meeting all the requirements of the contract.

**S-308.10.3--Central Plant Method.** Mixing in a central plant shall continue until a homogeneous mixture meeting specified requirements is obtained, and no varying appearance is evident. The mixing time may be adjusted by the Engineer as necessary.

**S-308.11--Shaping, Compacting, and Finishing.**

**S-308.11.1--General.** The mixed material shall be shaped as required immediately after mixing (or delivery to the roadbed in the case of central plant mixed material). Initial compaction shall begin immediately, and machining and compacting shall continue until the entire depth and width of the course is compacted to the required density within two hours of the time of beginning mixing. Equipment and methods which result in lamination shall not be used.

Areas inaccessible to rollers shall be compacted to the required density by other approved methods.

The addition of thin layers of cement-treated material in order to conform to cross sectional or grade requirements will not be permitted.

Compaction by vibration shall not be performed after the cement has taken its initial set. Vibratory compaction of a section shall be completed within one hour.

During compaction, a spike-tooth harrow or other suitable equipment shall be used as required to prevent lamination.

After the mixture (except the top mulch) is compacted, water shall be added as required to the mulch, and thoroughly mixed with a spike-tooth harrow or its equivalent to bring the mulch to the required moisture content.

The surface shall then be reshaped to the required lines, grades, and cross section, and if necessary shall be lightly scarified to remove imprints left by the compacting or shaping equipment. The surface shall then be sprinkled as necessary and thoroughly rolled with a pneumatic roller, and if the mixture contains plus No. 4 aggregate, at least one complete coverage of the section shall be made with a steel-wheel tandem roller.

Surface compaction and finishing for the entire section shall be performed in a manner that will produce a smooth, closely knit surface, free from laminations, construction cracks, ridges, or loose material, and conforming to the crown, grade, and lines stipulated within four hours after the beginning of mixing.

Upon completion of compaction, testing will be performed in accordance with S-700.03.

**S-308.11.2--Density.** Determination of acceptance of compaction of portland cement treated courses for required density will be performed on a lot to lot basis. Each lot will be each 2,500 linear feet per layer placed. At the discretion of the Engineer, a residual portion of a lot completed during a day's operation may be considered a separate lot or may be included in the previous or subsequent lot, except that any day's operation of less than one full lot will be considered a lot.

The lot will be divided into five approximately equal sublots with one density test taken at random in each subplot. The average of the five (5) density tests shall equal or exceed 98.0 percent with no single density test below 94.0 percent. Sublots with a density below 94.0 percent shall be corrected at no additional cost to the Project and retested for acceptance.

For cement treated materials other than for design soils and bases, the required density will be set out elsewhere in the contract.

**S-308.11.3--Width, Thickness, and Surface Requirements.** For the purpose of determining reasonable conformity with the designated width of a treated course, it shall be understood that the width of a treated course shall not vary from the designated edge lines by more than plus or minus one inch.

For the purpose of determining reasonable conformance with the designated thickness of a treated course, it shall be understood that the depth of a treated course shall not vary from the designated thickness by more than plus or minus one inch.

The finished surface of a treated course shall conform to the requirements shown on the plans, within the tolerances allowable in S-304.08.1.

**S-308.12--Protection and Curing.** Each completed course shall be covered with a bituminous curing seal as soon as practicable. The entire surface shall be kept continuously moist until the curing seal is applied. Asphalt emulsion shall be applied at the consistency specified in S-702 without further dilution with water. The rate of application of curing seals shall be 0.10 to 0.25 gallon per square yard.

The curing seal shall be continually maintained intact and reapplied as often as necessary for at least seven days. Where a bituminous base or pavement course is to be placed directly on the cement treated course, the curing seal shall be continually maintained and reapplied as often as necessary until covered by the bituminous base or pavement.

Before and while traffic or equipment is permitted on a cement treated course, it shall be the Contractor's responsibility to protect the curing seal from damage with sand or other blotter or cover material. All curing seal damaged or picked up shall be replaced immediately.

**S-308.13--Maintenance.** The Contractor shall maintain the cement treated course and the curing seal in a satisfactory condition until covered by a subsequent course. Maintenance shall include immediate repairs of surface irregularities or other defects that may occur. It shall be the Contractor's responsibility to control traffic and equipment loads to avoid damage and to guard against freezing of the course. All maintenance shall be performed at the expense of the Contractor and repeated as necessary to keep the cement treated material and the curing seal intact.

### **COMPENSATION**

**S-308.14--Method of Measurement.** Accepted soil-cement-water mixing will be measured by the square yard or ton.

Contractor furnished materials will be measured and paid for in accordance with the provisions for the governing pay items shown in the contract.

Portland cement incorporated in the accepted work, subject to the limitations set out in S-308.09.1, will be measured by the hundred weight (cwt) or per ton in accordance with the provisions of S-109.

Water and bituminous materials for the curing seal will not be measured for payment.

Unauthorized wastage or usage of any materials, unused materials remaining in stockpiles, and additional materials required for reconstruction of unacceptable work will be deducted from measured quantities. Determination of quantities to be deducted will be made by the method the State Aid Engineer considers to be most practicable and equitable, and his decision as to the method used shall be final.

**S-308.15--Basis of Payment.** Soil-cement-water mixing will be paid for at the contract unit price per square yard or per ton, as specified. Portland cement will be paid for at the contract unit price per hundred weight (cwt) or per ton. The prices thus paid shall be full compensation for completing the work specified.

Payment will be made under:

**S-308-A-1:** Portland Cement - per cwt

**S-308-A-2:** Portland Cement - per ton

**S-308-B-1:** Soil-Cement-Water Mixing ( \_\_\_\_\_ Mixers)\* - per square yard\*\*  
(Component)

**S-308-B-1:** Soil-Cement-Water Mixing ( \_\_\_\_\_ Mixers)\* - per ton\*\*  
(Component)

\*Optional, Single Pass, Multiple Pass, Traveling Plant, or Central Plant.

\*\* Central Plant Mixers Only.

**Section S-309 - Blank.**

**S-310.01--Description.** This work shall consist of constructing one or more courses by the incorporation of stabilizer aggregate in accordance with these specifications and in reasonably close conformity with the lines, grades, and cross sections shown on the plans or established by the Engineer.

**S-310.02--Materials.**

**S-310.02.1--Materials to be Stabilized.** The material to be stabilized shall consist of subbase or base material placed under this contract or under a previous contract.

General conditions governing the use of materials shall be as set out under S-106.

**S-310.02.2--Stabilizer Aggregates.** Stabilizer aggregates shall meet the requirements of S-703.20.

**S-310.02.3--Composite Mixture.** The composite mixture of mechanically stabilized courses shall be in accordance with the requirements and provisions of S-703.07. In order to obtain the desirable composite mixture, the Engineer may vary the quantity of stabilizer aggregate shown on the plans by as much as twenty-five (25) percent. In case the increase or decrease should amount to more than twenty five (25) percent the State Aid Engineer must give his approval before the work is accomplished.

Acceptance of the composite mixture for conformance to the specification requirements for gradation, liquid limit and plasticity index shall be based on samples obtained from the roadway. A minimum of one random sample shall be obtained for each 1000 linear feet of two lane roadway. In case a sample fails to meet the requirements of the specifications, additional samples shall be obtained to locate the limits of the non-conforming material. Such non-conforming material shall be corrected by the Contractor, at no additional costs to the Project, prior to final acceptance.

**S-310.03--Equipment.** Watering equipment shall be pressurized, have spray bars with suitable nozzle openings, and have controls for applying varying quantities of water.

Mixing shall be performed with multiple pass mixers, single pass mixers, traveling mixing plants, or central mixing plants. Unless otherwise specified, the type mixer used will be at the option of the Contractor.

Mixing equipment shall meet the applicable requirements of S-308.03.

Rollers shall be of sufficient number, type, size, and weight to accomplish the required compaction.

When measurement for payment is to be made by the ton, the Contractor shall furnish approved platform scales capable of weighing the entire loaded vehicle. Scales and their use shall be in accordance with the requirements set out in S-401.03.2.1.11, except they shall be installed at an approved location on or near the project.

### **CONSTRUCTION REQUIREMENTS**

**S-310.04--General.** The first section of each course to be constructed will serve as a test section. The length of the test section (at least one thousand (1000) linear feet, but not more than fifteen hundred (1500) linear feet for the designated width) will be determined by the capability of the equipment selected to perform the work.

The Engineer and the Contractor will evaluate results of the test section in relation to contract requirements. In case the Engineer determines the work is not satisfactory, the Contractor shall revise his procedures and augment or replace equipment as necessary to assure work is completed in accordance with the contract, and shall correct all deficient work at the expense of the Contractor.

Courses designated to be more than eight inches thick shall be constructed in two or more layers of approximate equal thickness. The maximum compacted thickness of a single layer shall not exceed eight inches.

When the plans indicate multiple courses, each course shall be mixed or spread, shaped, and compacted separately. Multiple courses shall be constructed so that each course is in direct contact with the preceding course, and a cushion of unstabilized material between layers will not be permitted.

When material for shoulders is of a different class or type from that specified for the course being constructed, the partial formation of shoulders shall precede the placement of aggregate or plant mixed material. Temporary drainage as necessary through partially constructed shoulders shall be provided and maintained until construction of the contiguous course.

No material shall be placed on or mixed with frozen material.

**S-310.05--Preparation of Grade.** Prior to placing material, the foundation shall be prepared in accordance with the requirements of S-304.08 for a sufficient distance in advance to insure proper prosecution of the work.

**S-310.06--Preparation of Materials.** The material to be stabilized shall be reasonably free from clay balls, roots, grass, organic matter, and other deleterious substances.

**S-310.07--Application of Stabilizer Aggregate (Road Mix Method).** When the roadbed has been prepared and approved, aggregate in the quantity specified shall be uniformly spread.

The Contractor shall provide sufficient equipment and shall organize the work so that the time interval between dumping and spreading of aggregate and subsequent incorporation shall be the minimum necessary to carry on an efficient and continuous operation. Dumping of long lines of aggregate on the roadbed and prolonged periods of hauling adjacent thereto will not be permitted. Unless prevented by unavoidable conditions, aggregate shall be incorporated, mixed, shaped, compacted, and finished not later than the second day following delivery to the roadbed.

**S-310.08--Mixing.**

**S-310.08.1--General.** During the mixing operations, clay balls and other undesirable materials present in sufficient quantity to impair the quality of the course shall be removed.

**S-310.08.2--Road Mix Method.** After the stabilizer aggregate has been uniformly spread, the material shall be scarified, if necessary, and the mixing operation begun immediately.

All preliminary scarifying and mixing shall be carefully controlled to provide an undisturbed foundation course with the designated grade and cross section.

The Contractor shall be responsible for damage to or contamination with the underlying material or shoulder material, and shall make corrections and repairs as necessary at no additional cost to the project.

All material to be stabilized shall be thoroughly mixed and pulverized by incorporating the added materials so that the course will be homogeneous throughout. During the mixing operation water shall be applied as necessary to obtain the moisture content required for compaction.

Particular care shall be exercised to ensure satisfactory moisture distribution along the edges of the course, and to avoid the application of excess water on any portion of a section.

**S-310.08.3--Central Plant Method.** Water shall be added during the mixing operation in the quantity necessary to provide the required moisture content. Mixing shall continue until a homogeneous mixture is obtained. After the mixing is complete, the mixture shall be transported while at the proper moisture content for compaction, and shall be placed on the prepared grade by means of an aggregate spreader.

The Contractor shall deliver to the roadbed a sufficient quantity of mixed material to produce the designated course. All material placed in excess of the tolerance allowable shall be removed and hauled back to plant without compensation, or removed and placed at other approved locations requiring use of the same material.

**S-310.09--Spreading, Compacting, and Finishing.** The mixed material shall be spread immediately after mix, or after delivery in the case of central plant mixed material. Spreading shall be carried out in a manner that will minimize segregation and will result in a completed course within the tolerances allowable.

Compaction shall start longitudinally at the outer edges of the course and proceed toward the center. The material shall be sprinkled or aerated as necessary during compaction to maintain the required moisture content.

Shaping and compaction shall be carried out in such a manner as to prevent lamination and shall continue until the entire depth and width of the course has obtained the required density. Throughout the entire compaction operation, the shape of the course shall be maintained by blading and rolling. Surface compaction and finishing shall be performed so as to produce a smooth, closely knit surface, free from lamination, cracks, ridges, or loose material, and conforming to the required section and the established lines and grades within the tolerances allowable.

Prior to subsequent construction, all irregularities, depressions, soft spots, and other deficiencies shall be corrected to meet the requirements of these specifications without additional compensation.

After compaction and finishing, if the mixture contains plus No. 4 aggregate and the course is to serve as a base for bituminous pavement, at least one complete coverage shall be made with a steel-wheel tandem roller.

In addition to the requirements for density and correction of irregularities, depressions, or soft spots, the Contractor shall be fully responsible for constructing and maintaining a course which will remain firm and stable under all construction equipment and other traffic to which the course is subjected prior to the acceptance of the work.



Density tests will be performed in accordance with the methods as provided in S-700.03. The specified density (SV) will be one hundred (100) percent for subbases and one hundred three (103) percent for bases. The unit of deviation (UD) will be one percentage point.

If the course is to be chemically treated, the required density will be ninety three (93) percent.

The finished surface of all courses shall conform to the required section and the established lines and grades, within the tolerances allowed in S-304.08.1. All finished courses shall be continually maintained until covered by a subsequent course or the work is accepted.

### COMPENSATION

**S-310.10--Method of Measurement.** Accepted mixing, shaping, and compaction will be measured by the square yard for each course included in the contract.

Accepted quantities of stabilizer aggregate will be measured by the cubic yard (LVM) or ton as designated in the bid schedule of the contract. Other materials (except water) specified and incorporated into accepted work will be measured and paid for under the provisions of the governing pay items shown in the contract.

When the method of measurement is by the ton, measurement will be made on the dry unit weight basis. The moisture determination for computing the dry weight will be made in accordance with the methods as provided in S-700.03 once a day and as many additional times as the Engineer deems necessary.

Unauthorized wastage or usage of materials, unused materials remaining in stockpiles, and additional materials required for correction of unacceptable work will be deducted from measured quantities. Determination of quantities to be deducted will be made by the method the Engineer considers to be most practicable and equitable, and his decision as to the method used for such computations shall be final.

**S-310.11--Basis of Payment.** Mixing, shaping, and compaction will be paid for at the contract unit price per square yard. Stabilizer aggregates will be paid for at the contract unit price per cubic yard(LVM) or ton. The prices thus paid shall be full compensation for completing the work specified.

Payment will be made under:

- S-310-A-1:** Size \_\_\_ Stabilizer Aggregate, Coarse - per cubic yard
- S-310-A-2:** Size \_\_\_ Stabilizer Aggregate, Coarse - per ton
- S-310-B-1:** Stabilizer Aggregate, Medium - per cubic yard
- S-310-B-2:** Stabilizer Aggregate, Medium - per ton
- S-310-C-1:** Stabilizer Aggregate, Fine - per cubic yard
- S-310-C-2:** Stabilizer Aggregate, Fine - per ton

**GENERAL ITEM**

- S-310-D:** Mixing, Shaping, and Compaction - per square yard

**S-311.01--Description.** This work consists of constructing one or more courses of a mixture of granular material, fly ash, lime, and water in accordance with these specifications and in reasonably close conformity with the lines, grades, thickness and typical cross sections shown on the plans or established by the Engineer.

Unless otherwise provided, the Contractor may use either the travel plant or central plant method.

**S-311.02--Materials.** Granular Material, shall conform to the requirements set forth on the plans or in the contract. Other materials shall conform to the requirements of S-700 as specified in the following subsections:

Cut-back Asphalt	S-702.06
Emulsified Asphalt	S-702.07
Granular Material	S-703.07
Water	S-714.01
Lime	S-714.03
Fly Ash	S-714.05

**S-311.02.1--Granular Material-Lime-Fly Ash Design.** Quantities and percentages of lime and fly ash shown on the plans are preliminary. The actual application rate will be established from tests made prior to beginning treatment. The design of granular material lime-fly ash courses shall be performed by the MDOT Central Laboratory or other approved laboratories. At least 45 days prior to the proposed use of a lime-fly ash course, the contractor shall make available materials conforming to the specifications and proposed for use in the mixture for sampling and testing by MDOT or other approved laboratories as the Engineer may consider necessary for the establishment of a mix design.

The approved proportions of material will govern during the progress of the work, and changes in source or character of any material shall not be made without approval. Approval will be based on verification of a mix design.

**S-311.02.2--Curing Seals.** Curing seal shall be Emulsified Asphalt, Grade EA-1, SS-1, CMS-2h, or MS-2h meeting the applicable requirements of S-702.

**S-311.03--Construction Requirements.**

**S-311.03.1--General.** The first section of the mixing operation, will serve as a test section. The length of the test section (not less than three hundred fifty (350) linear feet nor more than five hundred linear feet for the designated width) will be determined by the capabilities of the equipment provided to perform the work. The Engineer and the Contractor will evaluate the results of the test section in relation to contract requirements. In case the Engineer determines the work is not satisfactory, the Contractor shall revise his procedures and augment or replace equipment as necessary to assure work is completed in accordance with the contract and shall correct any deficient work at no additional cost to the project.

Fly ash shall be spread at the specified rate and lightly disked or mixed into the granular material prior to spreading the lime.

Prior to the application of fly ash, a light windrow shall be bladed along the edges of the area to be treated, or the surface on which the fly ash is to be applied shall be scarified to retain the spread fly ash. The depth of scarification shall be carefully controlled so that the surface of the roadbed below the scarified material will remain undisturbed and conform to the established cross section.

**S-311.03.2--Equipment.** Equipment necessary for the proper prosecution of the work shall meet the applicable requirements of S-308.03.

**S-311.03.3--Preparation of Grade.** Before treatment, the roadbed shall be prepared in accordance with the requirements of S-304.08.

**S-311.03.4--Application.**

**S-311-03.4.1--Fly Ash.** Fly Ash shall be applied as set out in S-308.09, except that weather limitations shall be in accordance with S-311.03.5.

**S-311-03.4.2--Lime.** The rate of application of lime shall be as specified.

Application of lime shall be accomplished by either an approved "dry application" or "slurry application" method.

The following guide lines will govern the acceptability of the method to be used:

**Dry Application.** Hydrated lime applied by this method shall be spread uniformly and shall be sprinkled with sufficient water to prevent loss of lime by wind. Spreading of hydrated lime when wind and weather conditions are unfavorable will not be permitted nor will spreading of lime by motor patrol be acceptable. The use of quick lime in the "dry application" method will not be permitted.

**Slurry Application.** Lime applied by this method shall be mixed with water in approved agitation equipment and applied to the roadbed as a thin water suspension or slurry.

The distributing equipment shall be equipped to provide continuous agitation of the slurry until applied on the roadbed. The proportion of lime shall be such that the "Dry Solids Content" shall be at least 30 percent by weight.

The distribution of lime at the rate specified shall be attained by one or more passes over a measured section until the specified percentage of lime has been spread. After each successive pass the material shall be incorporated into the soil with the mixing equipment.

**S-311.03.5--Weather Limitations.** Lime-fly ash treatment shall not be performed when either the granular material or the surface on which a lime-fly ash treated material is to be laid is wet or frozen or when it is raining or snowing. Processing operations for the lime-fly ash course shall not begin until the surface temperature is at least 40°F and rising. Construction of the granular material-lime-fly ash stabilized course will not be permitted between October 1 and March 1 without prior written approval by the State Aid Engineer.

**S-311.03.6--Fly Ash-Lime and Water Mixing Phase.** The lime and water shall be incorporated uniformly into the soil course of fly ash and aggregate. The mixing and water application shall be continued until a homogeneous mixture of which 100 percent of the material by dry weight, exclusive of gravel and stone, will pass a two inch sieve and 60 percent will pass a No. 4 sieve. At the completion of moist mixing and during the compaction operations, the percentage of moisture shall be that necessary to obtain the required density. No mellowing period will be required or permitted, and compaction shall begin immediately. The mixing, water application, and final compaction shall be completed during the same work day.

**S-311.03.7--Shaping, Compacting and Finishing.** The shaping, compacting, and finishing shall be in accordance with the provisions and requirements of Subsection S-308.11, except that, for the purpose of determining reasonable conformance with the designated thickness of the treated course, it shall be understood that the depth of the treated course shall not vary from designated thickness by more than minus one-half (1/2) inch or plus one (1) inch. Surface tolerances shall conform to the requirements of S-304.08.1.

**S-311.03.8--Protection and Curing.** The finished lime-fly ash base is to be covered with a curing seal as designated on the plans or in the contract within 48 hours. The course shall be kept continuously moist until the curing seal has been applied. The specified curing seal shall be applied by a pressure distributor at the rate of 0.10 to 0.25 gallon per square yard or as directed by the Engineer. The curing seal lime-fly ash base shall not have the following surface course applied until the prepared base has been approved by the Engineer.

The Contractor shall maintain the lime-fly ash course and the curing seal in a satisfactory condition until covered by a subsequent course.

Protection shall include immediate repairs of any surface irregularities or other defects that may occur or develop.

It shall be the Contractor's responsibility to control traffic and equipment loads to avoid damage and to guard against freezing of the lime-fly ash treated material.

All damage resulting from the Contractor's failure to protect and cure the lime-fly ash course as specified herein or from freezing that may occur prior to being covered with the next course shall be corrected at no additional cost to the County.

The Contractor shall submit for approval of the Engineer a method of correction that will restore the strength of the damaged material to that originally specified.

**S-311.04--Method of Measurement.** Lime and fly ash will be measured by the ton in accordance with S-109. If bagged lime is used the net weight as packaged by the manufacturer will be used for measurement.

The basis of payment for jobsite slaked lime slurry shall be the "calculated method" as provided for jobsite slaked lime slurry in S-307.10.

Granular Material will be measured as per S-304.09.

Curing seal and water shall not be measured for separate payment.

Processing will be measured by the square yard at the designated thickness and shall include preparation of the roadbed, scarifying, pulverizing, drying of the material, mixing of the various materials, compaction of the mixture, finishing, protection and curing, and maintenance of the completed course.

**S-311.05--Basis of Payment.** The accepted quantities of lime and fly ash treated material will be paid for at the contract price per ton for lime and fly ash. Granular Material shall be paid for by the cubic yard (LVM) or ton as per S-304.10. Processing lime and fly ash treated material complete in place shall be paid for per square yard at the designated thickness. The prices thus paid shall be full compensation for completing the work. Curing seal and Water shall not be paid for as a separate pay item and its cost shall be absorbed in other items bid.

Payment will be made under:

**S-311-A:** Processing Lime and Fly Ash Treated Course,  
( \_\_\_\_\_ " Thick) - per square yard

**S-311-B:** Lime - per ton

**S-311-C:** Fly Ash (Class \_\_\_\_\_) - per ton

**Sections S-312 thru S-319 - Blank.**

**S-320.01--Description.** This work shall consist of constructing the shoulder portion of courses specified to be constructed; the shaping, compacting, finishing, and surfacing, if required, of the shoulder portion of the work in reasonably close conformity with the required lines, grades, and cross sections; and the construction and establishment of erosion control items specified for the shoulder portion of the work. All work shall conform to the sequence and timing indicated herein and to the other applicable requirements of the contract.

This work shall also include preservation from injury or damage to and repair and reconstruction of, if necessary, underlying courses and other elements of the pavement structure. Except as otherwise specified, construction of shoulders shall also include reshaping, finishing, and mowing of cut ditches, foreslopes, and upper embankment slopes adjacent to shoulders. Areas to receive this work shall include the areas between the finished shoulder line and the same elevation at the back of the ditch in cut sections and the areas on fill slopes between the finished shoulder line and a line ten (10) feet horizontally outside the finished shoulder line. Similar areas in the median portion of divided highways shall also be reshaped and finished.

**S-320.02--Materials.** Materials used in constructing shoulders shall meet the applicable requirements of S-700.

**S-320.03--Construction Details.** Except as otherwise specified, the construction of each course of the shoulders shall be in accordance with controlling requirements for subbases and bases constructed of like material.

Shoulder construction shall begin at the earliest practicable time and proceed in the proper sequence with contiguous subbase, base, or pavement construction. Each designated course for shoulders shall be constructed to the established lines, grades, and cross sections within tolerances allowed and shall be firm and stable.

Determination of acceptance of compaction of shoulders for required density will be performed on a lot to lot basis. Each lot will consist of each day's operation per layer placed, with a maximum lot length of 10,000 linear feet.

The lot will be divided into five approximately equal sublots with one density test taken at random in each subplot. The lot average and each single density test shall conform to the required density.

The required density for the shoulder portion of any layer or course shall be the same as for the adjacent (internal) portion of the layer or course when constructed of the same material.



The required density for the shoulder portion of any layer or course where the adjacent (internal) portion is of unlike material shall be as follows:

Granular Material <u>Class</u>	Lot <u>Average</u>	Individual <u>Test</u>
10	94.0	90.0
7,8 or 9	95.0	91.0
5 or 6	96.0	92.0
3 or 4	97.0	93.0
1 or 2	98.0	94.0

except,

- (a) When the finished shoulder is required to be paved, the required density for such shoulder course shall be that required for the same material for bases, and
- (b) Where an existing pavement is to be overlaid, or widened and overlaid, without shoulder widening, and the existing shoulder is to be raised to match the new pavement, satisfactory density of each layer of new shoulder material shall be that which can be obtained from six coverages of a pneumatic roller with an operating weight of approximately six tons while the shoulder material is at the proper moisture content.

In cases of base or pavement in which portland cement is used as a material of construction, shoulder construction shall follow immediately upon expiration of the curing period, unless it has been otherwise provided that the shoulder course be constructed in advance of the contiguous course.

The rate of progress for each phase of shoulder construction shall be consistent with the rate of progress of the controlling construction. When the Engineer deems that other operations are being carried on to the unnecessary neglect of shoulder construction, the Engineer may suspend the operations in progress and order that shoulder construction be brought up to and then continued, without prejudice to other work, in the proper sequence.

**S-320.04 - Blank.**

**S-320.05--Basis of Payment.** Unless otherwise specified in the contract, no separate payment will be made for shoulder construction. Payment will be made for the materials and their processing when set up in the contract as pay items. All additional work involved in shoulder construction is considered an obligation of the Contractor subsidiary to the placement of the materials required and work performed for which provisions for payment are contained in the contract.

**Sections S-321 thru S-399 - Blank.**

<u>Section</u>	<u>Page</u>
S-400 - BITUMINOUS PAVEMENTS	4-1
S-401 - PLANT MIX PAVEMENTS (HMA) - GENERAL	4-1
S-402 - Blank	4-29
S-403 - HOT MIX ASPHALT PAVEMENT	4-30
S-404 - and S-405 - Blank	4-38
S-406 - COLD MILLING	4-39
S-407 - TACK COAT	4-41
S-408 - PRIME COAT	4-43
S-409 - GEOTEXTILE FABRIC FOR UNDERSEAL	4-45
S-410 - BITUMINOUS SURFACE TREATMENT	4-48
S-411 - SLURRY SEAL	4-59
S-412 - Blank	4-70
S-413 - CLEANING AND SEALING JOINTS AND CRACKS	4-71
S-414 - thru S-499 - Blank	4-75



**SECTION S-401 - PLANT MIX PAVEMENTS (HMA) - GENERAL**

**S-401.01--Description.** These specifications include general requirements that are applicable to all types of HMA along with the specific requirements for each particular mixture when deviations from the general requirements are necessary.

This work consists of the construction of one or more lifts of HMA in accordance with these specifications and the specific requirements for the mixture to be produced and in reasonably close conformity with the lines, grades, thicknesses and typical sections shown on the plans or established by the Engineer.

**S-401.01.1--Definitions.**

**Maximum Sieve Size** - Maximum sieve size is the smallest sieve size at which 100 percent of the aggregate passes.

**Nominal Maximum Sieve Size** -The nominal maximum sieve size is one sieve size larger than the first sieve to retain more than 10 percent of the aggregate.

**Maximum Density Line** - The maximum density line is a straight line plot on the FHWA 0.45 power gradation chart which extends from the zero origin point of the chart through the plotted point of the combined aggregate gradation curve on the nominal maximum sieve size.

**Mechanically Fractured Face** - An angular, rough, or broken surface of an aggregate particle created by crushing as determined by ASTM Designation: D 5821.

**S-401.02--Materials.**

**S-401.02.1--Component Materials.**

**S-401.02.1.1--General.** Component materials will be conditionally accepted at the plant subject to later rejection if incorporated in a mixture or in work which fails to meet contract requirements.

**S-401.02.1.2--Aggregates.** The source of aggregates shall meet the applicable requirements of S-703.

**S-401.02.1.2.1--Coarse Aggregate Blend.** Mechanically fractured faces by weight of the combined mineral aggregate coarser than the No. 4 sieve:

<u>Mixture</u>	<u>Percent Fractured Faces, minimum</u>
25 mm	70 (one face)
19 mm*	80 (one face)
12.5 mm	90 (two face)
9.5 mm	90 (two face)
4.75 mm	90 (two-face)

\*When used on routes requiring polymer modified asphalt, the top intermediate lift (19 mm mixture), including travel lane and adjacent lane, shall have at least 90 percent two fractured faces minimum.

The maximum percentage by weight of flat and elongated particles, for all mixes other than 4.75 mm, maximum to minimum dimension greater than 5, shall not exceed 10% for all mixtures. This shall be determined in accordance with ASTM Designation: D 4791, Section 8.4, on the combined mineral aggregate retained on the 3/8" sieve.

**S-401.02.1.2.2--Fine Aggregate Blend.** Of all the material passing the No. 8 sieve and retained on the No. 200 sieve, not more than 60 percent shall pass the No. 30 sieve.

Uncrushed natural sand shall pass the 3/8" sieve and may be used, excluding the content in RAP, in the percentages of the total mineral aggregate by weight set out in the following table:

Mixture	Maximum Percentage of Natural Sand by Total Weight of Mineral Aggregate		
	HT	MT	ST
25 mm	10	10	20
19 mm	10	10	20
12.5 mm	10	10	20
9.5 mm	10	10	10
4.75 mm	25	30	35

**S-401.02.1.2.3--Combined Aggregate Blend.****Design Master Range**

Mixture:	25 mm	19 mm	12.5 mm	9.5 mm	4.75 mm
Nominal Maximum Sieve Size:	1 inch	3/4 inch	1/2 inch	3/8 inch	1/4 inch
Sieve Size	Percent Passing				
1-1/2 inch	100				
1 inch	90-100	100			
3/4 inch	89 max.	90-100	100		
1/2 inch	-	89 max.	90-100	100	100
3/8 inch	-	-	89 max.	90-100	95-100
No. 4	-	-	-	89 max.	90-100
No. 8	16-50	18-55	20-60	22-70	-
No. 16	-	-	-	-	30-60
No. 200	4.0-9.0	4.0-9.0	4.0-9.0	4.0-9.0	6.0-12.0

For MT and HT mixtures, the combined aggregate gradation of the job mix formula, when plotted on FHWA 0.45 power chart paper, shall fall entirely below the Maximum Density Line on all sieve sizes smaller than the No. 4 sieve. However, MT and HT mixtures having a minimum fine aggregate angularity index of 44.0, per ASTM Designation: C1252, Method A, may be designed above the maximum density line.

The 9.5 mm mixtures shall have a minimum fine aggregate angularity of 44.0 for HT and MT mixtures and 40.0 for ST mixtures when tested on combined aggregate in accordance with ASTM Designation: C1252 Method A. The 4.75 mm mixtures shall have a minimum fine aggregate angularity of 45.0 for all design levels when tested on combined aggregate in accordance with ASTM Designation: C 1252, Method A.

The minus No. 40 fraction of the combined aggregate shall be non-plastic when tested according to AASHTO Designation: T 90. The clay content for the combined aggregate for underlying layers shall not exceed 1.0 percent, and for the top layer shall not exceed 0.5 percent by weight of the total mineral aggregate when tested according to AASHTO Designation: T 88.

**S-401.02.1.3--Bituminous Materials.** Bituminous materials shall meet the applicable requirements of Section S-702 for the grade specified.

Tack coat shall be the same neat grade asphalt cement used in the mixture being placed or those materials specified for tack coat in Table 410-A. Emulsified asphalt shall not be diluted without approval of the Engineer.

**S-401.02.1.4--Blank.**

**S-401.02.1.5--Hydrated Lime.** Hydrated lime shall meet the requirements of S-714.03.2 for lime used in soil stabilization.

**S-401.02.1.6--Asphalt Admixtures.** Additives for liquid asphalt, when required or permitted, shall meet the requirements of S-702.08.

**S-401.02.1.7--Polymers.** Polymers for use in polymer modified HMA pavements shall meet the requirements of S-702.08.3.

**S-401.02.2-- Blank.**

**S-401.02.3--Composition of Mixtures.**

**S-401.02.3.1--General.** Unless otherwise specified or permitted, the HMA shall consist of a mixture of asphalt, aggregate, hydrated lime and, when required or necessary to obtain desired properties, antistripping agent and/or other materials.

The total amount of crushed limestone aggregate for mixtures, excluding 4.75 mm mixtures, when used in the top lift, shall not exceed 50 percent of the total combined aggregate by weight.

Hydrated lime shall be used in all HMA at the rate of one percent (1%) by weight of the total dry aggregate including aggregate in RAP, if used. The aggregate, prior to the addition of the hydrated lime, shall contain sufficient surface moisture. If necessary, the Contractor shall add moisture to the aggregate according to the procedures set out in S-401.03.2.1.2.



The Contractor shall obtain a shipping ticket for each shipment of hydrated lime. The Contractor shall provide the Engineer and MDOT District Materials Engineer or other approved Testing Laboratory with a copy of each shipping ticket from the supplier, including the date, time and weight of hydrated lime shipped and used in hot mix asphalt production. An amount equal to twenty-five percent (25%) of the total value of HMA items performed during the initial estimate period in which the Contractor fails to submit the hydrated lime shipping tickets, as required, will be withheld from the Contractor's earned work. Non-conformance with this specification for successive estimate period(s) will result in the total value (100%) of HMA items performed during this period(s) being withheld from the Contractor's earned work. Monies withheld for this non-conformance will be released for payment on the next monthly estimate following the date the submittal of hydrated lime shipping tickets to the Engineer is brought back into compliance with this specification.

Mixtures will require the addition of an antistripping agent when the Tensile Strength Ratio (MT-63) and/or the Boiling Water Test (MT-59) fail to meet the following criteria.

Tensile Strength Ratio (TSR - MT-63)	
Wet Strength / Dry Strength	85 percent minimum
Interior Face Coating	95 percent minimum
Boiling Water Test (MT-59)	
Particle Coating	95 percent minimum

Reclaimed asphalt pavement (RAP) materials may be used in the production of HMA in the percentages of the total mix by weight set out in the following table:

HMA Mixture	Maximum percent RAP by total weight of mix
4.75 mm	0
9.5 mm	15
12.5 mm Top Lift	15
12.5 mm Underlying Lift	30
19 mm	30
25 mm	30

During HMA production, the RAP shall pass through a maximum 2-inch square sieve located in the HMA plant after the RAP cold feed bin and prior to the RAP weighing system.

Crushed reclaimed concrete pavement may be used as an aggregate component of all HMA pavements. When crushed reclaimed concrete pavement is used as an aggregate component, controls shall be implemented to prevent segregation. Crushed reclaimed concrete pavement aggregate shall be separated into coarse and fine aggregate stockpiles using the 3/8-in or 1/2-in sieve as a break-point unless otherwise approved by the Engineer in writing.

**S-401.02.3.1.1--Mixture Properties.**

ALL MIXTURES

Percent of Maximum  
Specific Gravity (Gmm)

N Design	96.0
N Initial	Less than 90.0
N Maximum	Less than 98.0

VMA CRITERIA

Minimum percent

Mixture	
25 mm	12.0
19 mm	13.0
12.5 mm	14.0
9.5 mm	15.0
4.75 mm	16.0

Mixtures with VMA more than two percent higher than the minimum may be susceptible to flushing and rutting; therefore, unless satisfactory experience with high VMA mixtures is available, mixtures with VMA greater than two percent above the minimum should be avoided.

The specified VFA range for 4.75 mm nominal maximum size mixtures for design traffic levels >3 million ESAL's (HT Mixtures) shall be 75 to 78 percent, for design traffic levels of 1.0 to 3 million ESAL's (MT mixtures) 65 to 78 percent, and for design traffic levels of <1.0 million ESAL's (ST mixtures) 65 to 78 percent.

DUST/BINDER RATIO for 4.75 mm mixtures

Percent Passing No.200 / Effective Binder Percent 0.9 to 2.0

DUST/BINDER RATIO for 9.5 mm, 12.5 mm, 19 mm & 25mm mixtures

Percent Passing No.200 / Effective Binder Percent 0.8 to 1.6

**S-401.02.3.2--Job Mix Formula.** The job mix formula shall be established in accordance with Mississippi Test Method: MT-78, where N represents the number of revolutions of the gyratory compactor.

Compaction Requirements:	$N_{\text{Initial}}$	$N_{\text{Design}}$	$N_{\text{maximum}}$
High Type (HT) Mixtures 19 mm, 12.5 mm, 9.5 mm & 4.75 mm	7	85	130
Medium Type (MT) Mixtures 19 mm, 12.5 mm, 9.5 mm & 4.75 mm	7	65	100
All Standard Type (ST) Mixtures; 25 mm HT & MT Mixtures	6	50	75

At least 15 working days prior to the proposed use of each mixture, the Contractor shall submit in writing to the Engineer a proposed job-mix formula or request the transfer of a verified job-mix formula. The job-mix formula shall be signed by a Certified Mixture Design Technician (CMDT).

MDOT or State Aid approved laboratory will perform the tests necessary for review of a proposed job-mix formula or transfer for each required mixture at no charge to the Contractor; however, a charge will be made for additional job-mix formulas submitted by the Contractor for review.

Review of the proposed job-mix formula will be based on percent maximum specific gravity at  $N_{\text{Initial}}$ ,  $N_{\text{Design}}$ , and  $N_{\text{Maximum}}$ , VMA @  $N_{\text{Design}}$ , resistance to stripping, and other criteria specified for the mixture.

The mixture shall conform thereto within the range of tolerances specified for the particular mixture. No change in properties or proportion of any component of the job-mix formula shall be made without permission of the Engineer. The job-mix formula for each mixture shall be in effect until revised in writing by the Engineer.

A job-mix formula may be transferred to other contracts in accordance with conditions set forth by the Engineer.

The Contractor shall not place any HMA prior to receiving "tentative" approval from the Engineer.

When a change in source of materials, unsatisfactory results or changed conditions make it necessary, a new job-mix formula will be required. The conditions set out herein for the original job-mix formula are applicable to the new job-mix formula.

**S-401.02.4--Substitution of Mixture.** The substitution of a one (1) size finer mixture for an underlying lift shall require written permission of the Engineer, except no substitution of a 4.75 mm mixture will be allowed. A 9.5 mm mixture may be substituted for the 12.5 mm mixture designated on the plans as the top lift or pre-leveling. The 19 mm mixture may be substituted for the 25 mm mixture in trench widening work. Any substitution of mixtures shall be of the same type. No other substitutions will be allowed. The quantity of substituted mixture shall be measured and paid for at the contract unit price for the mixture designated on the plans. The substitution of any mixture will be contingent on meeting the required total structure thickness and maintaining the minimum and/or maximum laying thickness for the particular substituted mixture as set out in the following table.

Mixture	Single Lift Laying Thickness Inches	
	Minimum	Maximum
25 mm	3	4
19 mm	2 ¼	3
12.5 mm	1 ½	2
9.5 mm	1	1 ½
4.75 mm	½	¾

**S-401.02.5--Contractor's Quality Management Program.**

**S-401.02.5.1--General.** The Contractor shall have full responsibility for quality management and maintain a quality control system that will furnish reasonable assurance that the mixtures and all component materials incorporated in the work conform to contract requirements. The Contractor shall have responsibility for the initial determination and all subsequent adjustments in proportioning materials used to produce the specified mixture. Adjustments to plant operation and spreading and compaction procedures shall be made immediately when results indicate that they are necessary. Mixture produced by the Contractor without the required testing or personnel on the project shall be subject to removal and replacement by the Contractor at no additional cost to the Project.

**S-401.02.5.2--Personnel Requirements.** The Contractor shall provide at least one Certified Asphalt Technician-I (CAT-I) full-time at each plant site used to furnish material to the project. Sampling shall be conducted by a certified technician or by plant personnel under the direct observation of a certified technician. All testing, data analysis and data posting will be performed by the CAT-I or by an assistant under the direct supervision of the CAT-I. The Contractor shall have a Certified Asphalt Technician-II (CAT-II) available to make any necessary process adjustments. Technician certification shall be in accordance with MDOT SOP TMD-22-10-00-000, MDOT HMA Technician Certification Program. An organizational chart, including names, telephone numbers and current certification, of all those responsible for the quality control program shall be posted in the contractor's laboratory while the asphaltic paving work is in progress.

**S-401.02.5.3--Testing Requirements.** As a minimum, the Contractor's quality management program shall include the following.

- (a) Bituminous Material. Provide Engineer with samples in sealed one quart metal containers at the required frequency according to current State Aid Standard Operating Procedures (SOP).
- (b) Mechanically Fractured Face. Determine mechanically fractured face content of aggregates retained on the No. 4 sieve, at a minimum of one test per day of production.
- (c) Mixture Gradation. Conduct extraction tests for gradation determination on the mixture. Sample according to the frequency in paragraph (i) and test according to Mississippi Test Method MT-31.
- (d) Total Voids and VMA. Determine total voids and Voids in Mineral Aggregate (VMA) at N Design, from the results of bulk specific gravity tests on laboratory compacted specimens. Sample according to the sampling frequency in paragraph (i), and test according to the latest edition of MDOT's field Manual for HMA.
- (e) Asphalt Content. Sample according to the sampling frequency in paragraph (i). Determine the asphalt content using one of the following procedures.
  - (1) Nuclear gauge. (Mississippi Test Method MT-6)
  - (2) Incinerator oven per AASHTO Designation: T 308, Method A.

- (f) Stripping Tests. Conduct a minimum of one stripping test at the beginning of each job-mix production and thereafter, at least once per each two weeks of production according to Mississippi Test Method: MT-63 and one stripping test per day of production according to Mississippi Test Method: MT-59. Should either the TSR (MT-63) or the boiling water (MT-59) stripping tests fail, a new antistripping additive or rate shall be established or other changes made immediately that will result in a mixture which conforms to the specifications; otherwise, production shall be suspended until corrections are made.
- (g) Density Tests. For 25 mm, 19.5 mm, 12.5 mm & 9.5 mm mixtures, conduct density tests as necessary to control and maintain required compaction according to Mississippi Test Method: MT-16, Method C (nuclear gauge), or AASHTO Designation: T 166. Note - The nuclear gauge may be correlated, at the Contractor's option, with the average of a minimum of five pavement sample densities. For 4.75 mm mixtures, conduct density tests as necessary to control and maintain required compaction according to AASHTO Designation: T 166.
- (h) Quality Control Charts. Plot the individual test data, the average of the last four tests and the control limits for the following items as a minimum:

Mixture Gradation (Percent Passing) Sieves:

1/2-in, 3/8-in, No. 8, No. 16, No. 30 and No. 200.

Asphalt Content, Percent

Maximum Specific Gravity,  $G_{mm}$

Total Voids @  $N_{Design}$ , Percent

VMA @  $N_{Design}$ , Percent

**NOTE:** For 4.75 mm mixtures, Quality Control Charts for mixture gradation are not required on the No. 8 and No. 30 sieves. For 4.75 mm mixtures, as a minimum, Quality Control Charts for mixture gradation shall be kept on the 3/8-in, No. 16 and No. 200 sieves. For all mixtures other than 4.75 mm, Quality Control Charts for mixture gradation are not required on the No. 16 sieve.

Keep charts up-to-date and posted in a readily observable location. Charts may be kept on a computer, however, the charts shall be printed out a minimum of once each production day and displayed in the laboratory. Note any process changes or adjustments on the Air Voids chart.

- (i) Sampling Frequency. Conduct those tests as required above at the following frequency for each mixture produced based on the estimated plant tonnage at the beginning of the day.

<u>Total Estimated Production, tons</u>	<u>Number of Tests</u>
50-800	1
801-1700	2
1701-2700	3
2701+	4

**NOTE:** Material placed in a storage silo from a previous day's production shall be randomly sampled and tested when removed for placement on the roadway. Such sample(s) shall be independent of the day's production sampling frequency and shall be used in calculating the four (4) sample running average.

- (j) Sample Requirements. Obtain the asphalt mixture samples from trucks at the plant. Obtain aggregate samples from cold feed bins or aggregate stockpile. Save a split portion of all mixture samples at the laboratory site in a dry and protected location for 14 calendar days. At the completion of the project, the remaining samples may be disposed of with the approval of the Engineer.

The above testing frequencies are for the estimated plant production for the day. If production is discontinued or interrupted, the tests will be conducted at the previously established sample tonnage points for the materials that are actually produced. If the production exceeds the estimated tonnage, sampling and testing will continue at the testing increments previously established for the day. A testing increment is defined as the estimated daily tonnage divided by the required number of tests from the table in S-401.02.5.3 paragraph (i).

In addition to the above program, the following tests shall be conducted on the first day of production and once for every eight production samples thereafter, with a minimum of one test per production week.

Aggregate Stockpile Gradations per AASHTO Designations: T-11 and T-27.

Reclaimed Asphalt Pavement (RAP) Gradation per Mississippi Test Method MT-31.

Fine Aggregate Angularity for all 4.75 mm and 9.5 mm mixtures and all MT and HT mixtures designed above the maximum density line per ASTM Designation: C 1252, Method A.

Testing of the aggregate and RAP stockpiles during production will be waived provided the Contractor provides the Engineer with gradation test results for the materials in the stockpile determined during the building of the stockpiles. The test results provided shall represent a minimum frequency of one per one thousand tons of material in the stockpile. If the Contractor continues to add materials to the stockpile during HMA production, the requirements for gradation testing during production are not waived.

**S-401.02.5.4--Documentation.** The Contractor shall document all observations, records of inspection, adjustments to the mixture, and test results on a daily basis. All tests conducted by the Contractor in accordance with S-401.02.5.3(h) shall be included in the running average calculations. If single tests are performed as a check on individual HMA properties, between regular samples, without performing all tests required in S-401.02.5.3(h), the results of those individual tests shall not be included in the running average calculations for the particular property. The Contractor shall record the results of observations and records of inspection as they occur in a permanent field record. The Contractor shall record all process adjustments and job mix formula (JMF) changes on the air void charts. The Contractor shall provide copies of all test data sheets and the daily summary reports on the appropriate forms to the Engineer on a daily basis. The Contractor shall provide a written description of any process change, including blend proportions, to the Engineer as they occur. Information provided to the Engineer must be received in the Engineer's office by no later than 9:00 AM the day after the HMA is produced. Fourteen days after the completion of the placement of the HMA, the Contractor shall provide the Engineer with the original testing records and control charts in a neat and orderly manner.

**S-401.02.5.5--Control Limits.** The following control limits for the job mix formula (JMF) and warning limits are based on a running average of the last four data points.

Item	JMF Limits	Warning Limits
Sieve-% passing		
1/2-in	$\pm 5.5$	$\pm 4.0$
3/8-in	$\pm 5.5$	$\pm 4.0$
No. 8	$\pm 5.0$	$\pm 4.0$
No. 16, for 4.75 mm mixtures ONLY	$\pm 4.0$	$\pm 3.0$
No. 30	$\pm 4.0$	$\pm 3.0$
No. 200	$\pm 1.5$	$\pm 1.0$
Asphalt Content %	- 0.3 to + 0.5	- 0.2 to + 0.4
Total Voids @ N Design %	$\pm 1.3$	$\pm 1.0$
VMA @ N Design, %	- 1.5	- 1.0



**S-401.02.5.6--Warning Bands.** Warning bands are defined as the area between the JMF limits and the warning limits.

**S-401.02.5.7--Job Mix Formula Adjustments.** A request for a JMF adjustment signed by a CAT-II may be made to the Engineer by the Contractor. Submit sufficient testing data with the request to justify the change. The requested change will be reviewed by the Engineer. If current production values meet the mixture design requirements, a revised JMF will be issued. Adjustments to the JMF shall conform to the latest edition of MDOT's Field Manual for HMA. Adjustments to JMF limits to conform to actual production shall not exceed the tolerance specified for the JMF limits. Regardless of such tolerances, any adjusted JMF gradation shall be within the design master range for the mixture specified. The JMF asphalt content may only be reduced if the production VMA meets or exceeds the minimum design VMA requirements for the mixture being produced.

**S-401.02.5.8--Action and Adjustments.** Based on the process control test results for any property in question, the following actions shall be taken or adjustments made when appropriate:

- (a) When the running average trends toward the warning limits, the Contractor shall consider taking corrective action. The corrective action, if any, shall be documented. All tests shall be part of the contract files and shall be included in the running average calculations.
- (b) The Contractor shall notify the Engineer whenever the running average exceeds the warning limits.
- (c) If two consecutive running averages exceed the warning limit, the Contractor shall stop production and make adjustments. Production shall only be restarted after notifying the Engineer of the adjustments made.
- (d) If the adjustments made under (c) improve the process such that the running average after four additional tests is within the warning limits, the Contractor may continue production with no reduction in payment.
- (e) If the adjustment made under (c) does not improve the process and the running average after four additional tests stays in the warning band, the mixture will be considered unsatisfactory. Reduced payment for unsatisfactory mixtures will be applied starting from the stop point to the point when the running average is back within the warning limits in accordance with S-401.02.6.3.

- (f) Failure to stop production and make adjustments when required shall subject all mixture produced from the stop point to the point when the running average is back within the warning limits to be considered unsatisfactory. Reduced payment for unsatisfactory mixtures will be applied in accordance with S-401.02.6.3.
- (g) If the running average exceeds the JMF limits, the Contractor shall stop production and make adjustments. Production shall only be restarted after notifying the Engineer of the adjustments made.
- (h) All materials for which the running average exceeds the JMF limits will be considered unacceptable and shall be removed and replaced by the Contractor at no additional cost to the Project. The Engineer will determine the quantity of material to be replaced based on a review of the individual testing data which make up the running average in question and an inspection of the completed pavement. If the Engineer decides to leave the mixture in place because of special circumstances, the quantity of mixture, as defined above, will be paid for in accordance with S-401.02.6.3.
- (i) Single test results shall be compared to twice the warning and JMF limits. If the test results verified by a State Aid approved Laboratory or MDOT (within allowable differences in S-401.02.6.2) exceed these limits, the pay factor provided in S-401.02.6.3 will apply for the quantity of material represented by the test(s). Single test limits will be used for the acceptance of projects when insufficient tonnage is produced to require four (4) Contractor's tests.
- (j) The above corrective action will also apply for a mixture when the Contractor's testing data has been proven incorrect. The Contractor's data will be considered incorrect when; 1) the Contractor's tests and the Engineer's tests do not agree within the allowable differences given in S-401.02.6.2 and the difference can not be resolved, or 2) the Engineer's tests indicates that production is outside the JMF limits and the results have been verified by MDOT or other State Aid approved Laboratory. The Engineer's data will be used in place of the Contractor's data to determine the appropriate pay factor.

**S-401.02.6--Standards of Acceptance.**

**S-401.02.6.1--General.** Acceptance for mixture quality (VMA and total voids at N Design, gradation, and asphalt content) will be based on random samples tested in accordance with the latest edition of MDOT's Field Manual for HMA. Pavement densities and smoothness will be accepted by lots as set out in S-401.02.6.4 and S-401.02.6.5.

**S-401.02.6.2--Test for Mixture Quality.** The rounding of test results will be in accordance with S-700.04.

The Engineer will conduct tests on split samples taken by the Contractor or samples may be chosen by the Engineer anytime during production. The frequency will be equal to or greater than the latest SOP for State Aid Road Construction. All testing and data analysis shall be performed by a Certified Asphalt Technician-I (CAT-I) or by an assistant under the direct supervision of the CAT-I.

The Engineer shall be allowed to inspect measuring and testing devices to confirm calibration and condition. The Contractor shall calibrate and correlate all testing equipment in accordance with the latest version of the MDOT Test Methods.

Difference between the Contractor's and Engineer's split sample test results will be considered acceptable if within the following limits:

<b>Item</b>	<b>Allowable Differences</b>
<b>Sieve - % Passing</b>	
<b>3/8-in and above</b>	<b>6.0</b>
<b>No. 4</b>	<b>5.0</b>
<b>No. 8</b>	<b>4.0</b>
<b>No. 16, for 4.75 mm mixtures ONLY</b>	<b>3.5</b>
<b>No. 30</b>	<b>3.5</b>
<b>No. 200</b>	<b>2.0</b>
<b>AC Content</b>	<b>0.4</b>
<b>Specimen Bulk SG (Gmb) @ N Design</b>	<b>0.030</b>
<b>Maximum SG (Gmm)</b>	<b>0.020</b>

In the event comparison test results are outside the above allowable differences, the Engineer will investigate the reason immediately. The Engineer's investigation may include testing of the remaining split samples, review and observation of the Contractor's testing procedures and equipment and a comparison of split sample test results by the contractor quality control laboratory, State Aid approved laboratory or MDOT Materials Division. In the event reasons for the differences cannot be determined, the Engineer's results will be used for the quality control data and the appropriate payment for the mixture and asphalt will be based on the procedures specified in S-401.02.5.8.

The Engineer may witness the sampling and testing being performed by the contractor. The Engineer, both verbally and in writing, will promptly notify the Contractor of any observed deficiencies. When differences exist between the contractor and the Engineer which cannot be resolved, a decision will be made by the State Aid Engineer, acting as the referee, and will in writing promptly notify the Contractor. If the deficiencies are not corrected, the Engineer will stop production until corrective action is taken.

**S-401.02.6.3--Acceptance Procedure for Mixture Quality.** All obviously defective material or mixture will be subject to rejection by the Engineer. Such defective material or mixture shall not be incorporated into the finished work. If the defective material has already been placed in the work, the material shall be removed and replaced at no additional cost to the Project.

The Engineer will base final acceptance of the asphalt mixture production on the results of the Contractor's testing for total voids and VMA @  $N_{Design}$  gradation, and asphalt content as verified by the Engineer in the manner hereinbefore described and the uniformity and condition of the completed pavement. Areas of pavement that exhibit non-uniformity or failures, materials or construction related, such as but not limited to segregation, bleeding, shoving, rutting over 1/8", raveling, slippage, or cracking will not be accepted. Such areas will be removed and replaced at no additional cost to the Project.

Bituminous mixture placed prior to correction for deficiencies in VMA and total voids @  $N_{Design}$  gradation, or asphalt content, as required in S-401.02.5.8 and determined by the Engineer satisfactory to remain in place will be paid for in accordance with the following pay factors times the contract unit price per ton.

**Pay Factor for Mixture Quality \***

Item	Produced in Warning Bands	Produced Outside JMF Limits, Allowed to Remain in Place
Gradation	0.90	0.75
Asphalt Content	0.85	0.75
Total Voids @ $N_{Design}$	0.70	0.50
VMA @ $N_{Design}$	0.90	0.75

\*The minimum single payment will apply.

**S-401.02.6.4--Acceptance Procedure for Density.** Each completed lift will be accepted with respect to compaction on a lot basis from density tests performed by the Engineer. For normal production days, divide the production into approximately equal lots as shown in the following table. When cores are being used for the compaction evaluation, randomly obtain one core from each lot. When the nuclear density gauge is being used for compaction evaluation, obtain two random readings from each lot and average the results. Additional tests may be required by the Engineer to determine acceptance of work appearing deficient. The Contractor shall furnish and maintain traffic control for all compaction evaluations, including coring, required in satisfying specified density requirements.

Lot Determination

<u>Daily Production - Tons</u>	<u>Number of Lots</u>
0-300	1
301-600	2
601-1000	3
1001-1500	4
1501-2100	5
2101-2800	6
2801+	7

**S-401.02.6.4.1--Roadway Density.** The density requirement for each completed lift on a lot to lot basis from density tests performed by the Engineer shall be as follows:

1. For all single lift overlays, with or without leveling and/or milling, the required lot density shall be 92.0 percent of maximum density.
2. For all multiple lift overlays of two (2) or more lifts excluding leveling lifts, the required lot density of the bottom lift shall be 92.0 percent of maximum density. The required lot density for all subsequent lifts shall be 93.0 percent of maximum density.
3. For all pavements on new construction, the required lot density for all lifts shall be 93.0 percent of maximum density.

When it is determined that the density for a lot is below the required density (93.0 percent or 92.0 percent) but not lower than 91.0 or 90.0 percent of maximum density, respectively, the Contractor will have the right to remove and replace the lot(s) not meeting the specified density requirements in lieu of accepting reduced payment for the lot(s).

When it is determined that the density for a lot is above 96.0 percent, the Engineer shall notify the Contractor who will make plant adjustments to resolve the problem.

When it is determined that the density for a lot is below 91.0 or 90.0 percent, respectively, the lot(s), or portions thereof shall be removed and replaced in accordance with Chapter 7 of the latest edition of MDOT's Field Manual for HMA at no additional cost to the Project. A corrected lot will be retested for approval. No resampling will be performed when pavement samples are used for determining density.

At any time the average daily compaction (the total of the percent compaction for the lots produced in one day divided by the total number of lots for the day) does not meet the required percent compaction or more for two consecutive days, the Contractor shall notify the Engineer of proposed changes to the compactive effort. If the average daily compaction does not meet the required percent compaction or more for a third consecutive day, the Contractor shall stop production until compaction procedures are established to meet the specified density requirements.

Each lot of work found not to meet the density requirement of 92.0% or 93% of maximum density, respectively, may remain in place with a reduction in payment as set out in the following tables:

**PAYMENT SCHEDULE FOR COMPACTION  
OF 92.0 PERCENT OF MAXIMUM DENSITY**

<u>Pay Factor</u>	<u>Lot Density ** % of Maximum Density</u>
1.00	92.0 and above
0.90	91.0 - 91.9
0.70	90.0 - 90.9

\*\* Any lot or portion thereof with a density of less than 90.0 percent of maximum density shall be removed and replaced at no additional cost to the Project.

**PAYMENT SCHEDULE FOR COMPACTION  
OF 93.0 PERCENT OF MAXIMUM DENSITY**

<u>Pay Factor</u>	<u>Lot Density *** % of Maximum Density</u>
1.00	93.0 and above
0.90	92.0 - 92.9
0.70	91.0 - 91.9

\*\*\* Any lot or portion thereof with a density of less than 91.0 percent of maximum density shall be removed and replaced at no additional cost to the Project.

The compaction pay factors and mixture quality pay factor, as described in S- 401.02.6.3, will each apply separately. However, the combined pay factor shall not be less than 0.50 for any mixture allowed to remain in place.

**S-401.02.6.4.2--Trench Widening Density.** The density for trench widening on a lot to lot basis shall be determined from density tests performed by the Engineer using pavement samples (cores).

When it is determined that the density for a trench widening lot is below 89.0 percent but not lower than 88.0 percent of maximum density, the Contractor will have the right to remove and replace the lot(s) not meeting the specified density requirements in lieu of accepting reduced payment for the lot(s).

When it is determined that the density for a trench widening lot is above 95.0 percent, the Engineer shall notify the Contractor who will make plant adjustments to resolve the problem.

When it is determined that the density for a trench widening lot is below 88.0 percent, the lot(s), or portions thereof shall be removed and replaced in accordance with Chapter 7 of the latest edition of MDOT's Field Manual for HMA at no additional cost to the Project. A corrected lot will be retested for approval. No resampling will be performed when pavement samples are used for determining density.

At any time the daily compaction (the total of the percent compaction for the lots produced in one day divided by the total number of lots for the day) does not meet 89.0 percent compaction or more for two consecutive days, the Contractor shall notify the Engineer of proposed changes to the compactive effort. If the average daily compaction does not meet 89.0 percent compaction or more for a third consecutive day, the Contractor shall stop production until compaction procedures are established to meet the specified density requirement.

Each lot of trench widening work found not to meet the density requirement of 89.0 percent of maximum density may remain in place with a reduction in payment as set out in the following table:

**PAYMENT SCHEDULE FOR COMPACTION  
TRENCH WIDENING WORK**

<u>Pay Factor</u>	<u>Lot Density *** % of Maximum Density</u>
1.00	89.0 and above
0.50	88.0 - 88.9

\*\*\* Any lot or portion thereof with a density of less than 88.0 percent of maximum density shall be removed and replaced at no additional cost to the Project.

The compaction pay factors and mixture quality pay factor, as described in S-401.02.6.3, will each apply separately. However, the combined pay factor shall not be less than 0.50 for any mixture allowed to remain in place.

**S-401.02.6.5--Acceptance Procedure for Pavement Smoothness.** When compaction is completed, the lift shall have a uniform surface and be in reasonably close conformity with the line, grade and cross section shown on the plans.

When required by the Engineer, and approved by the State Aid Engineer, the smoothness of each applicable lift will be determined by using a California profilograph to produce a profilogram (profile trace) at each designated location. The surface shall be tested and corrected to a smoothness index as described in MDOT Specifications.



**S-401.02.6.7--Surface Correction.** Corrective work to bumps shall consist of diamond grinding in accordance with these specifications or methods approved by the Engineer. All surface areas corrected by grinding shall be sealed with a sealant approved by the Engineer.

**S-401.02.6.7.1--Diamond Grinding.** Grinding of asphalt surfaces shall consist of diamond grinding the existing asphalt pavement surface to remove surface distortions to achieve the specified surface smoothness requirements.

**S-401.02.6.7.2--Equipment.** The grinding equipment shall be a power driven, self-propelled machine that is specifically designed to smooth and texture pavement surfaces with diamond blades. The effective wheel base of the machine shall not be less than 12.0 feet. It shall have a set of pivoting tandem bogey wheels at the front of the machine and the rear wheels shall be arranged to travel in the track of the fresh cut pavement. The center of the grinding head shall be no further than 3.0 feet forward from the center of the back wheels.

The equipment shall be of a size that will cut or plane at least 2.0 feet wide. It shall also be of a shape and dimension that does not encroach on traffic movement outside of the work area. The equipment shall be capable of grinding the surface without causing spalls at joints, or other locations.

**S-401.02.6.7.3--Construction.** The construction operation shall be scheduled and proceed in a manner that produces a uniform finish surface. Grinding will be accomplished in a manner to provide positive lateral drainage by maintaining a constant cross-slope between grinding extremities in each lane.

The operation shall result in pavement that conforms to the typical cross-section and the requirements specified in S-401.02.6.7.4. It is the intent of this specification that the surface smoothness characteristics be within the limits specified.

The Contractor shall establish positive means for removal of grinding residue. Solid residue shall be removed from pavement surfaces before it is blown by traffic action or wind. Residue shall not be permitted to flow across lanes used by public traffic or into gutters or drainage facilities, but may be allowed to flow into adjacent ditches.

**S-401.02.6.7.4--Finished Pavement Surface.** The grinding process shall produce a pavement surface that is smooth and uniform in appearance with a longitudinal line type texture. The line type texture shall contain parallel longitudinal corrugations that present a narrow ridge corduroy type appearance. The peaks of the ridges shall not be more than 1/16 inch higher than the bottoms of the grooves.

The finished pavement surface will be measured for riding quality. The grinding shall produce a riding surface which does not exceed either the specified profile index or the specified bump and dip limit.

**S-401.02.7--Nuclear Gauges.**

**S-401.02.7.1--Nuclear Moisture-Density Gauge.** The nuclear gauge unit used to monitor density shall contain a full data processor which holds all calibration constants necessary to compute and directly display wet density, moisture, and dry density in pounds per cubic foot. The data processor shall compute and display the percent moisture and percent density based on dry weight.

**S-401.02.7.2--Nuclear Asphalt Content Gauge.** The Contractor shall furnish and calibrate, unless designated otherwise in the contract, a Troxler Nuclear Asphalt Content Gauge (Model 3241 or updated model) or a Campbell Nuclear Asphalt Content Gauge (Model AC-2) or an approved equal.

**S-401.03--Construction Requirements.** State Aid has adopted the AASHTO “Hot-Mix Asphalt Paving Handbook” as the guideline for acceptable HMA construction practices.

**S-401.03.1--Specific Requirements.**

**S-401.03.1.1--Weather Limitations.** The mixture shall not be placed when weather conditions prevent the proper handling and finishing or the surface on which it is to be placed is wet or frozen. At the time of placement, the air and pavement surface temperature limitations shall be equal to or exceed that specified in the following table.

**TEMPERATURE LIMITATIONS**

<b>Compacted Thickness</b>	<b>Temperature</b>
<b>Less than 1 1/2 inches</b>	<b>55°F</b>
<b>1 1/2 inches to 2 inches</b>	<b>50°F</b>
<b>2 1/4 inches to 3 inches</b>	<b>45°F</b>
<b>Greater than 3 inches</b>	<b>40°F</b>

When paving operations are discontinued because of rain, the mixture in transit shall be protected until the rain ceases. The surface on which the mixture is to be placed shall be swept to remove as much moisture as possible and the mixture may than be placed subject to removal and replacement at no additional cost to the Project if contract requirements are not met.

**S-401.03.1.2--Tack Coat.** Tack coat shall be applied to previously placed primed subbase/base, road surface and between layers, unless otherwise directed by the Engineer. The tack coat shall be applied as a spray coating, fog coating, or “spider webbing”. Construction requirements shall be in accordance with S-407.

**S-401.03.1.3--Blank.**

**S-401.03.1.4--Density.** The lot density for all dense graded pavement lifts, except as provided below for preleveling, wedging {less than fifty percent (50%) of width greater than minimum lift thickness}, ramp pads, irregular shoulder areas, median crossovers, turnouts, or other areas where the established rolling pattern cannot be performed, shall not be less than 92.0 percent of the maximum density based on AASHTO Designation: T209 for the day's production. If a job-mix formula adjustment is made during the day which affects the maximum specific gravity, calculate a new average maximum density for the lot(s) placed after the change.

Pavement core samples obtained for determining density which have a thickness less than two times the maximum size aggregate permitted by the job-mix formula will not be used as a representative sample.

Preleveling, wedging {less than fifty percent (50%) of width greater than minimum lift thickness}, ramp pads, irregular shoulder areas, median crossovers, turnouts, and other areas where an established rolling pattern cannot be obtained shall be compacted to refusal densification.

**S-401.03.2--Bituminous Mixing Plants.****S-401.03.2.1--Plant Requirements.**

**S-401.03.2.1.1--Cold Aggregate Storage.** The cold storage for hydrate lime shall be a separate bulk storage bin with a vane feeder or other approved feeder system which can readily be calibrated. The system shall provide a means for easy sampling of the hydrated lime additive and verifying the quantity of lime dispensed. The feeder system shall require a totalizer.

The hydrated lime additive equipment shall be interlocked and synchronized with the cold feed controls to operate concurrently with the cold feed operation which will automatically adjust the hydrated lime feed to variations in the cold aggregate feed. A positive signal system shall be installed which will automatically shut the plant down when malfunctions cause an improper supply of hydrated lime or water.

The plant shall not operate unless the entire hydrated lime system is functioning properly.

**S-401.03.2.1.2--Cold Aggregate Feed.** The hydrated lime shall be dispensed dry or as a slurry (1 part hydrated lime to 3 parts water) directly onto the composite aggregate between the cold feed and the dryer.

When hydrated lime is introduced dry, a spray bar or other approved system capable of spraying all aggregate with water shall be installed in order to maintain all aggregate at the moisture condition set out in S-401.02.3.1 prior to addition of the hydrated lime. An alternate system for spraying the coarse aggregate stockpiles may be allowed when approved by the Engineer. The approved equipment and methods shall consistently maintain the aggregate in a uniform, surface wet condition. The moisture content of the aggregate-hydrated lime mixture, following spraying and mixing, shall be introduced into the automatic moisture controls of the plant.

The aggregate-hydrated lime mixture shall be uniformly blended by some mechanical means such as a motorized "on the belt" mixer or pug mill located between the cold feed and the dryer. Other mixing devices may be used subject to approval by the Engineer.

A maximum of forty five (45) percent of the total aggregate blend may be fed through any single cold feed bin. If the JMF calls for more than forty five (45) percent of a specific aggregate, that aggregate must be fed through two (2) or more separate cold feed

**S-401.03.2.1.3--Dryer.** The efficiency of drying aggregates shall be such that the moisture content of the top HMA mixture shall not exceed 0.50 percent by weight of the total mixture, and the moisture content of all the underlying mixtures shall not exceed 0.75 percent by weight of the total mixture being produced.

**S-401-03.2.1.4--Blank.**

**S-401.03.2.1.5--Control of Bituminous Material and Antistripping Agent.** Specified bituminous materials from different manufacturers or from different refineries of a single manufacturer shall not be mixed in the plant's asphalt cement supply system storage tank and used in the work without prior written approval of the Engineer. Approval is contingent upon the Engineer's receipt of three copies of the manufacturer's certified test report(s) from the Contractor showing that the bituminous material blend conforms to the specifications.

A satisfactory method of weighing or metering shall be provided to ensure the specified quantity of bituminous material. Provisions shall be provided for checking the quantity or rate of flow. Weighing or metering devices shall be accurate within plus or minus one-half percent.

The antistripping agent shall be injected into the bituminous material immediately prior to the mixing operation with an approved in-line injector system capable of being calibrated so as to ensure the prescribed dosage.

An in-line spigot for sampling of asphalt shall be located between the asphalt storage tank and the antistripping agent in-line injector.

**S-401.03.2.1.6--Thermometric Equipment.** An armored thermometer of adequate range and calibrated in 5°F increments shall be fixed at a suitable location in the bituminous line near the charging valve of the mixer unit.

The plant shall be equipped with an approved dial-scale, mercury-actuated thermometer, pyrometer or other approved thermometric instrument placed at the discharge chute of the dryer to measure the temperature of the material.

When the temperature control is unsatisfactory, the Engineer may require an approved temperature-recording apparatus for better regulation of the temperature.

**S-401.03.2.1.7--Screens.** A scalping screen shall be used.

**S-401.03.2.1.8--Dust Collector.** The plant shall be equipped with a dust collector constructed to waste or return collected material. When collected material is returned, it shall be returned through a controlling device which will provide a uniform flow of material into the aggregate mixture.

**S-401.03.2.1.9--Safety Requirements.** A platform or other suitable device shall be provided so the Engineer will have access to the truck bodies for sampling and mixture temperature data.

**S-401.03.2.1.10--Blank.**

**S-401.03.2.1.11--Truck Scales.** The specifications, tolerances and regulations for commercial weighing and measuring devices as recommended by the National Bureau of Standards {National Institute of Standards and Technology (NIST) handbook 44} shall govern truck scales used in the State of Mississippi, except weighing devices with a capacity of ten thousand (10,000) pounds or more used to weigh road construction materials (i.e. sand, gravel, asphalt, fill dirt, topsoil and concrete) shall have a tolerance of one-half of one percent (1/2 of 1%) in lieu of the requirements of Handbook 44 and shall be regulated by the Mississippi Department of Transportation.

Scales shall be checked and certified by a scale company certified in heavy truck weights by the Mississippi Department of Agriculture and Commerce. In the case of scales used for measurement of materials on Department of Transportation projects or State Aid projects, certification shall be performed in the presence of an authorized representative of MDOT or a copy of the certification may be furnished for scales that have been checked and certified within the last six months for use on other Department of Transportation or State Aid projects and are still in the position where previously tested. Scales that have not been checked and certified under NIST Handbook 44 guidelines, except for the herein modified tolerances allowed, shall be so checked and certified prior to use for measurement of materials on Department of Transportation or State Aid projects. Tests shall be continued on six month intervals with the test conducted in the presence of an authorized representative of MDOT.

Truck scales shall be accurate to one-half percent of the applied load, shall be sensitive to 20 pounds, and shall have a graduation of not more than 20 pounds.

The Contractor may use an electronic weighing system approved by the Engineer in lieu of truck scales. The system shall be equipped with an automatic print out system which will print a ticket for each load with the following information:

State Aid, Contractor's name, project number, county, ticket number, load number, pay item number, item description of the material delivered, date, time of day, haul vehicle number, gross weight, tare weight, net weight and total daily net weight.

When approved by the Engineer, and materials are measured directly from a storage bin equipped with load cells, exceptions may be made to the gross and tare weight requirement.

The ticket shall also have a place for recording the temperature of HMA mixtures, if applicable, and the signatures of the Engineer's plant and roadway inspectors. The load numbers for each project shall begin with load number one (1) for the first load of the day and shall be numbered consecutively without a break until the last load of the day. The Contractor shall provide the Engineer with an original and one copy of each ticket. When the ticket information provided by the Contractor proves to be unsatisfactory, the Engineer will use imprinter(s) and imprinter tickets to record load information. All recorded weights shall be in pounds and shall be accurate to within one-half of one percent of the true weight, and the system shall be sensitive to 20 pounds. The Engineer will require random loads to be checked on certified platform scales at no cost to the project.

When an electronic weighing system utilizes the plant scales of a batch plant, the system may be used only in conjunction with a fully automatic batching and control system.

#### **S-401.03.2.2--Additional Requirements for Batching Plants.**

**S-401.03.2.2.1--Plant Scales.** The plant batch scale weight shall not exceed the platform scale weight by more than one percent (1%).

#### **S-401.03.2.3--Additional Requirements for Drum Mixing Plants.**

**S-401.03.2.3.1--Plant Controls.** The plant shall be operated with all the automatic controls as designed and provided by the plant manufacturer. If the automatic controls malfunction, brief periods of manual operations to complete the day's work or to protect the work already placed may be conducted with the approval of the Engineer. During manual operation, the Contractor must continue to produce a uniform mixture meeting all contract requirements.

**S-401.03.2.3.2--Aggregate Handling and Proportioning.** A screening unit shall be placed between the bins and the mixer to remove oversized aggregate, roots, clayballs, etc.

**S-401.03.2.4--Surge or Storage Bins.** Surge and/or storage systems may be used at the option of the Contractor provided each system is approved by the Engineer prior to use. Surge bins shall be emptied at the end of each day's operation. Storage silos may be used to store mixtures as follows:

19 mm & 25 mm mixtures	24 hours
9.5 mm & 12.5 mm mixtures	36 hours

The storage silos must be well sealed, completely heated and very well insulated. The mixture when removed from the storage silo shall be tested to ensure that it meets all the same specifications and requirements as the mixture delivered directly to the paving site. See S-401.02.5.3, subparagraph (i) for sampling and testing requirements.

**S-401.03.3--Hauling Equipment.** The inside of each vehicle bed shall be coated with a light application of water and thin oil, soap solution, lime water solution or other approved material to prevent the mixture from sticking. Diesel fuel or gasoline shall not be used to lubricate vehicle beds. Truck beds shall be raised to drain excessive lubricants before placing mixture in the bed. An excess of lubricant will not be permitted.

**S-401.03.4--Bituminous Pavers.** The screed or stroke-off assembly shall be capable of vibrating and heating the full width of the mixture being placed and shall lay the lift with an automatic control device to the specified slope and grade without tearing, pulling or gouging the mixture surface.

**S-401.03.5--Rollers.** All rollers shall be self-propelled units capable of maintaining a smooth and uniform forward and reverse speed as required for proper compaction. They shall be equipped with adjustable scrapers, water tanks, mats and a device for wetting the wheels or tires to prevent the mixture from sticking. Adhesion of the mixture to the rollers will not be permitted. The use of diesel fuel or gasoline for cleaning roller wheels or tires or to aid in preventing the mixture from sticking to the wheels or tires is prohibited.

All rollers shall be in good mechanical condition, free from leaking fuels and lubricants, loose link motion, faulty steering mechanism, worn king bolts and bearing. They shall be operational at slow speeds to avoid displacement of the mixture and capable of reversing direction smoothly and without backlash.

**S-401.03.6--Preparation of Grade.** The foundation upon which HMA pavement is to be placed shall be prepared in accordance with plans and specifications.

Unless otherwise directed, tack coat shall be applied to the underlying surface on which the mixture is to be placed. Emulsions, if used, must be allowed to “break” prior to placement of the bituminous mixture.

Bituminous mixture shall not be placed against the edge of pavements, curbs, gutters, manholes and other structures until sprayed with a thin uniform tack coating. The tack coat shall be protected until the mixture has been placed.

Existing pavements that require preliminary leveling or patching in advance of placing the bituminous mixture shall be sprayed with a tack coat material and then brought as nearly as practicable to uniform grade and cross section. The material shall be placed by hand or machine in one or more compacted layers approximately two (2) inches or less in compacted thickness.

**S-401.03.7--Blank.**

**S-401.03.8--Preparation of Mixture.** The temperature of the mixture, when discharged from the mixer, shall not exceed 340°F.

**S-401.03.9--Material Transfer Equipment.** Except for the areas mentioned below, when placing the top intermediate lift and/or the top lift of HMA pavements, the material transferred from the hauling unit shall be remixed prior to being placed in the paver hopper or insert by using an approved Materials Transfer Device. Information on approved devices can be obtained from the MDOT State Construction Engineer. Areas excluded from this requirement include: temporary work of short duration, detours, bridge replacement projects having less than 1,000 feet of pavement on each side of the structure, acceleration and deceleration lanes less than 1,000 feet in length, tapered sections, transition sections for width, shoulders less than 10 feet in width, crossovers, ramps, side street returns and other areas designated by the Engineer.

**S-401.03.10--Spreading and Finishing.** Grade control for HMA pavements shall be established by string line at least 500 feet ahead of spreading, unless placement is adjacent to curb and gutter, concrete pavement, or other allowed grade control.

The mixture shall be spread to the depth and width that will provide the specified compacted thickness, line, grade and cross section. Placing of the mixture shall be as continuous as possible. On areas where mechanical spreading and finishing is impracticable, the mixture may be spread, raked and luted by hand tools.

Immediately after screeding and prior to compaction, the surface shall be checked by the Contractor and irregularities adjusted. When the edge is feathered as in a wedge lift, it may be sealed by rolling. Irregularities in alignment and grade along the edges shall be corrected before the edges are rolled.



Hauling, spreading and finishing equipment shall be furnished that is capable of and operated in such a manner that the rolling operation will satisfactorily correct any surface blemishes.

The longitudinal joint in the subsequent lift shall offset that in the underlying lift by approximately six (6) inches. However, the joint in the top lift shall be at the centerline or lane line.

**S-401.03.11--Compaction.** After the mixture has been spread and surface irregularities corrected, it shall be thoroughly and uniformly compacted to the required line, grade, cross section and density.

**S-401.03.12--Joints.** Joints between previously placed pavement and pavement being placed shall be so formed as to insure thorough and continuous bond.

Transverse construction joints shall be formed by cutting the previously placed mixture to expose the full depth of the lift.

The contact surface of transverse joints and longitudinal joints, except hot joints, shall be sprayed with a thin uniform tack coating before additional mixture is placed against the previously placed material.

Longitudinal joints shall be formed by overlapping the screed on the previously placed material for a width of at least one (1) inch and depositing the quantity of mixture to form a smooth, tight joint.

**S-401.03.13--Pavement Samples.** The Contractor shall cut samples from each lift of HMA at the time and locations designated by the Engineer. The samples shall be taken for the full depth of each lift and shall be of a size approved by the Engineer but not to exceed 120 square inches. Tools used for cutting or coring of samples shall be of the revolving blade type such as saw or core drill. Cores shall be taken using a 4.0 to 6.0-inch inside diameter coring bit. The sample hole shall be filled, compacted and finished by the Contractor to conform with the surrounding area. No additional compensation will be allowed for furnishing samples and repairing the areas with new pavement.

**Section S-402 - Blank.**

**S-403.01--Description:** This work consists of constructing one or more lifts of HMA pavement meeting the requirements of S-401 on a prepared surface in accordance with the requirements of this section and in reasonably close conformity with the lines, grades, thicknesses, and typical cross sections shown on the plans or established by the Engineer.

**S-403.02--Material Requirements:** Materials and their use shall conform to the applicable requirements of S-401.02.

**S-403.03--Construction Requirements.**

**S-403.03.1--General.** Construction requirements shall be as specified in S-401.03 except as otherwise indicated in this section or applicable special provisions.

**S-403.03.2--Smoothness Tolerances.** Except as noted herein, the finished smoothness of each lift shall conform to the designated grade and cross section within the following tolerances from grade stakes or other grade reference points set at 25 foot intervals:

	Lower * & Leveling Lifts	Lower * Intermediate Lifts	Top Intermediate Lift	Surface Lift
Max. deviation from grade and cross section at any point.....	1/2"	3/8"	1/4"	1/4"
Max. deviation from a 10 foot straight edge...	3/8"	1/4"	1/8"	1/8"

\* When tested longitudinally from a string line located equidistant above points 50 feet apart, the distance from the string line to the surface at any two points located 12 1/2 feet apart shall not vary one from the other more than the maximum deviation allowed above from a 10 foot straight edge.

Grade stakes or other grade reference points set at 25-foot intervals and maximum deviation from grade and cross section will not be required provided an approved profile averaging device is furnished and properly used for the five conditions set forth herein; however, all other surface requirements are applicable.

- (a) Overlays with one overall lift.
- (b) Overlays with two or more overall lifts -- for each lift above the first overall lift provided each underlying overall lift is within the allowable tolerances.
- (c) Surface lift of new construction provided the underlying lift is within the allowable tolerances.
- (d) Full-depth asphalt construction for lifts above the lower lift provided the lower lift is within the specified tolerances for the lower intermediate lift.
- (e) Base lifts.

Acceptance and payment of HMA will be determined on a lot to lot basis by cores taken from the completed pavement as outlined in S-403.03.3.

Approved contacting type profile averaging devices are those devices capable of working in conjunction with a taut string or wire set to grade, or ski-type device with extreme contact points with the surface at least 30 feet apart. Approved non-contacting type profile averaging devices are laser type ski devices with at least four referencing mobile stations at a minimum length of 24 feet, or an approved equal.

When approved by the Engineer, a short ski or shoe may be substituted for a long ski on the second paving operation working in tandem.

During the finishing and compacting of base and pavement lifts, it shall be the responsibility of the Contractor to check the surface and joints for progress toward conformance to surface requirements set forth herein. Variations from surface requirements exceeding the allowable tolerances shall be corrected at the Contractor's expense.

**S-403.03.3--Thickness Requirements.** Hot mix asphalt overlay lifts shall be constructed as nearly in accordance with the thickness shown on the plans as the underlying pavement and foundation will permit. Periodic and cumulative yield tests will be made to determine practicable conformity to the thickness of each lift. The Engineer may order modifications in placement thicknesses to prevent unwarranted variations in plan quantities.

When the paver is operating off an established grade line, no thickness determination will be required for the various lifts of base and pavement. It is understood that the tolerances from design grade will control the thickness requirements.

When grade stakes are eliminated as outlined in S-403.03.2, acceptance and pavement will be determined on a lot to lot basis by cores taken from the completed pavement. Lots will be coincidental with acceptance lots for the surface lift as provided in S-401.02.6.4, except that only lots resulting from the placement of mainline surface lift will be used for thickness assessment. One core will be obtained at random for each lot. Irregular areas will not be cored.

When the average thickness of all the cores from the lots representing a day's production (excluding any discarded by the Engineer for justifiable reason) is within  $3/8$  of an inch of the total pavement thickness shown on the plans, excluding lift(s) placed using an established grade line, corrective action will not be required and a price adjustment will not be made for non-conformity to specified thickness.

When the average thickness of all the cores from the lots representing a day's production is deficient in thickness by more than  $3/8$  of an inch of the total pavement thickness shown on the plans, excluding lift(s) placed using an established grade line, the deficiency shall be corrected by overlaying the entire length of the day's production. The thickness of the overlay shall be equal to the thickness deficiency but no less than the minimum single lift laying thickness for the specified mixture.

When the thickness of all the cores from the lots representing a day's production is more than  $3/8$  of an inch thicker than the total thickness shown on the plans, excluding lift(s) placed using an established grade line, a price adjustment will be made in accordance with S-403.05.1.

The cores shall be cut and removed by the Contractor in the presence of the Engineer's representative and turned over to the Engineer's representative for further handling. The Contractor shall fill each core hole with HMA and compact to the satisfaction of the Engineer within 24 hours after coring.

**S-403.03.4--Lift Corrections.** Pavement exceeding the allowable surface tolerances shall be corrected at the Contractor's expense by the following methods:

Lower, Leveling and Lower Intermediate Lifts:

- (a) Removal or addition of mixture by skin patching, feather edging, wedge lift construction of full depth patching where appropriate and can be completed in a satisfactory manner.
- (b) Superimposing an additional layer which shall be an approved grade raise for the full width and length of the area to be corrected.

#### Top Intermediate Lift

- (a) Removal and the addition of sufficient mixture to provide the specified thickness. Corrections by this method shall be square or rectangular in shape and shall completely cover the area to be corrected.
- (b) Superimposing an additional layer (minimum lift thickness for mixture being used) which shall be an approved grade raise for full lane width of the area to be corrected. Transverse joints shall be perpendicular to the centerline of the pavement.

#### Surface Lift:

- (a) Removal and the addition of sufficient mixture to provide new material of at least minimum single lift laying thickness for full lane width of the area to be corrected. Transverse joints shall be perpendicular to the centerline of the lane.
- (b) Superimposing an additional layer (minimum lift thickness for mixture being used) which shall be an approved grade raise for full lane width of the area to be corrected. Transverse joints shall be perpendicular to the centerline of the pavement.

All mixtures used in the correction of unacceptable pavement shall be approved by the Engineer prior to use.

#### **S-403.03.5-- Overlays or Widening and Overlays.**

**S-403.03.5.1--General.** In addition to the requirements of S-403.03.1 through S-403.03.4 the following requirements will be applicable when an existing pavement is to be overlaid or widened and overlaid.

**S-403.03.5.2--Sequence of Operations.** In order to expedite the safe movement of traffic and to protect each phase of the work as it is performed, a firm sequence of operations is essential. Unless otherwise provided in the traffic control plan and/or the contract, the following appropriate items of work shall be begun and continually prosecuted in the order listed:

- (a) In sections designated by the Engineer, trim the shoulders along the pavement edges to provide drainage from the pavement.
- (b) Perform selective undercutting and patching as directed ( S-403.03.5.4 ).

- (c) Clean and seal joints. (If required)
- (d) Complete preparation on one side of roadway to be widened and place widening materials.
- (e) Reconstruct shoulders to elevation necessary to assure traffic safety.
- (f) Open the widened section to traffic.
- (g) Complete above work for other side of roadway.
- (h) Perform preliminary leveling as directed.
- (i) Apply interlayer (If required).
- (j) Place the first overall leveling lift. (If required)
- (k) After the first overall leveling lift, reconstruct shoulders as necessary to eliminate vertical differentials which may be hazardous to traffic.
- (l) Place first intermediate lift. (If required)
- (m) Construct shoulders to the contiguous elevation as required.
- (n) Place remaining intermediate lift (if required)
- (o) Place surface lift.
- (p) Complete construction of shoulders.
- (q) Apply permanent traffic marking.
- (r) Final cleanup.

The above operations shall be performed in such a manner that traffic will be maintained on a paved surface at all times. Two-lane highways should not be restricted to a single lane in excess of a 3,000 foot section.

**S-403.03.5.3--Widening of Base or Pavement.** The foundation for widening shall be formed by trenching or excavating to the required depth and constructing a smooth, firm and compacted foundation. It shall have sufficient density and stability to withstand the placement and compaction of subsequent lifts. Soft, yielding and other unsuitable material which the Engineer determines will not compact readily shall be removed and backfilled with granular material or hot mix asphalt as directed.

Except as provided herein, excavation for widening, undercutting or other required excavation shall be spread along the edge of the shoulders, foreslopes or other adjacent areas as directed and will be an absorbed item. When the quantity is in excess of what may be used satisfactorily on adjacent areas, the Engineer may direct that the material be loaded, hauled and spread uniformly on other designated areas. In this case, compensation for handling surplus material will be in accordance with the appropriate pay items as provided in the contract or as extra work.

If the plans require widening of the shoulders or embankment with contractor furnished material, all suitable material obtained from widening excavation may be used and will be measured and paid for as Contractor furnished materials. No measurement for payment of haul will be made.

Removal and disposal of old stakes, forms and other debris encountered in excavating shall be in accordance with S-201 and shall be considered as incidental to and included in the unit prices bid for other items. No separate measurement will be made therefor. Pavement edges and surfaces shall be cleaned prior to final shaping and compaction of adjacent trenching or undercut areas.

Granular material for widening shall be placed on a previously prepared, smooth, firm and unyielding foundation in accordance with the typical section. Density of the granular material shall be that specified for subbase.

Hot mix asphalt for widening, including trench widening, shall meet the applicable requirements of this section and S-401 and shall be placed in one or more layers as shown on the plans or as directed. The surface of the mixture shall be finished as a continuation of the adjacent pavement slope.

Trench rollers or other compaction equipment shall be used to compact the foundation, granular material and bituminous mixtures for widening when standard width rolling equipment cannot be used.

**S-403.03.5.4--Patching.** Existing pavement which has failed or unsatisfactorily stabilized shall be removed as directed. Removal of pavement will be measured and paid for under the appropriate pay items as provided in the contract.

Backfill shall consist of hot mix asphalt or a combination of compacted layers of granular material and hot mix asphalt. Unless otherwise specified, the Engineer will make this determination based on depth and field conditions.

Hot mix asphalt used for backfilling will be measured and paid for at the contract unit price for the mixture designated on the plans as the lowest lift. Granular material will be measured and paid for under the appropriate pay item as provided in the contract or as extra work.

**S-403.03.5.5--Preliminary Leveling.** All irregularities of the existing base or pavement that result in a thickness greater than approximately two and one-half inches for the first overall leveling lift shall be corrected by skin patching, feather edging or a wedge lift and shall be approved by the Engineer in advance of placing the first overall lift.

**S-403.03.5.6--Placement of Lifts.** The leveling lift shall be placed in a layer (or layers) not exceeding approximately two and one-half inches compacted thickness.

When single lane construction is required, placement of a lift on the adjacent lane may be performed by an approved profile averaging device provided the lane previously placed is within the allowable tolerances for all surface requirements. When any of the tolerances are exceeded, the contractor shall reestablish the control string line for laying the adjacent lane should he elect to perform this work prior to correcting the deficiencies of the lane previously placed. In no case shall a "matching shoe" be used to control the grade of an adjacent lane.

In instances where there are only minor deviations from the allowable tolerances in the first overall lift, the Engineer may permit the Contractor to place the next higher lift by graded string line in lieu of making the corrections.

Single lane placement of leveling, intermediate and surface lifts shall be limited to the distance covered in one and one-half days in advance of that placed in the adjacent lane.

**S-403.03.5.7--Protection of Pavement.** The base and pavement shall be protected and properly maintained until it has been compacted and cooled sufficiently for use by traffic.

**S-403.04--Method of Measurement.** HMA pavement, complete in place and accepted, will be measured by the ton. The weight of the composite mixture shall be determined in accordance with the provisions of S-401.03.2.1.11.

Unless shown as a separate pay item, the furnishing and application of the tack coat will not be measured for payment. When payment is provided, tack coat will be measured as set out in S-407.06.

The quantity of bituminous mixture required to correct the work, when made at the expense of the Contractor, will not be measured for payment.



Any trenching required for widening will not be measured for payment; the cost thereof shall be included in other items of work.

Undercut required by the Engineer will be measured for payment under the appropriate excavation item as provided in the contract or as extra work. Pavement removal and any required trenching will not be included in the measurement for undercut.

**S-403.05--Basis of Payment.** Subject to the adjustments set out in S-401.02.6.3, S-401.02.6.4 & S-403.03.2, hot mix asphalt pavement, complete-in-place, accepted, and measured as prescribed above, will be paid for at the contract unit price per ton for each lift of pavement specified in the bid schedule and shall be full compensation for completing the work.

**S-403.05.1--Price Adjustment for Thickness Requirement.** When grade stakes are eliminated as provided in S-403.03.3 and the average thickness of all cores from lots representing a day's production is more than 3/8 inch thicker than the total specified thickness of the pavement, excluding lift(s) placed using an established grade line, a lump sum reduction in payment for the surface lift of lots representing a day's production will be made as follows:

$$\begin{array}{l} \text{(Individual Day's} \\ \text{L.S. Reduction)} \end{array} = \begin{array}{l} \text{(Monetary Value of the Day's} \\ \text{Surface Lift Production)} \end{array} \times \frac{\text{(D - 3/8)}}{\text{ST}}$$

Where:

D = The day's average deviation from total pavement thickness shown on the plans excluding lift(s) placed using an established grade line.

ST = Specified thickness for lift.

The total L.S. reduction for the project is the summation of the individual day's reductions in payment.

**S-403.05.2--Pay Items**

Payment will be made under:

**S-403-A:** Hot Mix Asphalt,  $\frac{(1)}{\text{Type}}$   $\frac{(2)}{\text{Mixture}}$  - per ton

**S-403-B:** Hot Mix Asphalt,  $\frac{(1)}{\text{Type}}$   $\frac{(3)}{\text{Mixture}}$  , Leveling - per ton

**S-403-C:** Hot Mix Asphalt,  $\frac{(1)}{\text{Type}}$   $\frac{(4)}{\text{Mixture}}$  , Trench Widening - per ton

**S-403-D:** Hot Mix Asphalt, HT  $\frac{(3)}{\text{Mixture}}$  , Polymer Modified - per ton

**S-403-E:** Hot Mix Asphalt, HT  $\frac{(3)}{\text{Mixture}}$  , Polymer Modified, Leveling - per ton

- (1) ST, MT or HT
- (2) 4.75 mm mixture, 9.5 mm mixture, 12.5-mm mixture, 19-mm mixture or 25-mm mixture
- (3) 4.75 mm mixture, 9.5 mm mixture, 12.5-mm mixture, or 19-mm mixture
- (4) 19-mm mixture or 25-mm mixture

**Sections S-404 and S-405 - Blank.**

**S-406.01--Description.** This work consists of removal of pavement materials on the roadway and shoulders by cold milling to the designated depth and, loading, hauling, and disposal of the milled materials by the Contractor in accordance with the plans and specifications, or as directed by the Engineer. The milled surface shall provide a desirable surface free from gouges, continuous grooves, ridges, oil film, and other imperfections of workmanship and shall have a uniform appearance.

**S-406.02--Blank.**

**S-406.03--Construction Requirements.**

**S-406.03.1--Equipment.** The equipment to be used for this work shall be a self-propelled milling machine capable of removing a minimum width of four feet. The equipment shall have sufficient power, traction, and stability to remove material and maintain an accurate grade and cross slope. The equipment shall be capable of accurately and automatically establishing profile grades along each edge of the machine by referencing from the existing pavement with means of an approved profile averaging device with extreme contact points with surface at least 30 feet apart, or from an independent grade line and shall have an automatic system for controlling cross slope. The machine shall be equipped with an integral loading and reclaiming means to immediately remove material being cut from the surface and discharge the cuttings into a truck or windrow, all in one operation.

Adequate back-up equipment, such as mechanical sweepers, loaders, water truck, etc., and personnel shall be provided to insure that all cuttings are removed immediately behind the milling machine.

**S-406.03.2--Construction Methods.** On the roadway, when hot mix asphalt will be required on the milled area, milling operations shall not begin until the Contractor has an approved job-mix formula and is prepared to begin paving operations. The milled roadway area opened to public traffic shall be covered by placing the first required course within 30 calendar days after milling. During the period from November 1 to March 1, the uncovered milled area shall not exceed one mile of full roadway width.

The pavement and shoulder materials shall be removed to the depth, width, grade, and cross section shown on the plans, or as directed by the Engineer. The number of passes necessary to accomplish the work required herein and on the plans shall be determined by the Contractor.

The surface of the pavement and shoulders, after milling, shall be reasonably smooth and true to the established line, grade and cross section. Areas damaged by the Contractor's operations shall be corrected and/or repaired as directed by the Engineer at no additional costs to the Project. The Contractor shall take necessary action to prevent or minimize the ponding of water on the milled roadway and shoulder.

Where traffic is required to be maintained adjacent to the milled area, no more than a 2¼-inch differential in grade between the milled area and the adjacent surface will be allowed, unless a positive separation in accordance with the plans and specifications is established between the traffic and milled area.

A longitudinal pavement edge that traffic is expected to move across should have an elevation difference of not more than 2¼ inches. If the pavement edge is more than 1½ inches and less than or equal to 2¼ inches, uneven pavement signs will be required as shown in the plans, or contract documents. If the pavement edge is less than or equal to 1½ inches, no uneven pavement signs will be required. Transverse pavement joints shall be sufficiently tapered to allow for the safe movement of traffic.

When traffic is required to be maintained adjacent to milled shoulders, traffic control devices shall be placed in accordance with the requirements of the Traffic Control Plan, or as directed by the Engineer.

It is understood that the milled shoulder shall be covered with the next required course as soon as possible but in no case later than 30 calendar days after milling.

**S-406.04--Method of Measurement.** Cold milling of pavement, all depths, will be measured by the square yard. Loading, hauling, and disposal will not be measured for separate payment.

**S-406.05--Basis of Payment.** Cold milling of pavement, all depths, measured as prescribed above, will be paid for at the contract unit price per square yard, which price shall be full compensation for completing the work.

When not shown as a separate pay item in the contract, the price for each item of cold milling shall include the cost of continuous maintenance of traffic and protective services as required by the Traffic Control Plan, including all required individual traffic control devices.

Payment will be made under:

- S-406-A:** Cold Milling of Bituminous Pavement, All Depths - per square yard
- S-406-B:** Cold Milling of Concrete Pavement, All Depths - per square yard

**S-407.01--Description.** This work shall consist of preparing and treating an existing bituminous or concrete surface with bituminous material in accordance with these specifications and in reasonably close conformity with the lines shown on the plans or established by the Engineer.

### **MATERIALS**

**S-407.02--Bituminous Material.** The materials shall conform to the applicable requirements of S-702. The particular type and grade will be specified in the contract or by the Engineer.

When emulsified asphalt is used, the Engineer may require dilution with additional water to meet job conditions, but it shall not be diluted without approval of the Engineer.

### **CONSTRUCTION**

**S-407.03--Equipment.** The Contractor shall provide equipment for heating and applying bituminous material. Heating equipment and distributors shall meet the applicable requirements of S-410.08. Other equipment for applying tack coat shall be approved by the Engineer prior to use.

**S-407.04--Preparation of Surface.** The existing surface shall be prepared in accordance with S-401.03.6 and S-410.09.

**S-407.05--Application of Bituminous Material.** The tack coat shall be applied in such a manner as to offer the least inconvenience to traffic and to permit one-way traffic without pickup or tracking of the bituminous material. Tack coat shall not be applied during wet or cold weather, after sunset, or to a wet surface. The quantity, rate+ of application, temperature, and areas to be treated shall be approved prior to application, and the applied tack coat shall be properly cured prior to superimposed construction.

### **COMPENSATION**

**S-407.06--Method of Measurement.** Unless shown as a separate pay item in the proposal, tack coat will not be measured for direct payment, but shall be considered a necessary part of the construction involved, and the cost thereof shall be included in the appropriate contract price.

When shown as a separate pay item, bituminous tack coat material will be measured by the gallon as specified in S-410.12.

Emulsified asphalt will be measured before dilution.

**S-407.07--Basis of Payment.** When shown as a separate pay item in the contract, tack coat will be paid for at the contract unit price per gallon, which price shall be full compensation for completing the work specified.

Payment will be made under:

**S-407-A:** Asphalt for Tack Coat, ( \_\_\_\_\_ ) - per gallon  
(Grade)

**S-408.01--Description.** This work shall consist of preparing and treating an existing surface with bituminous material and blotter material, if required, in accordance with these specifications and in reasonably close conformity with the lines shown on the plans or established by the Engineer.

### **MATERIALS**

**S-408.02--Bituminous Materials.** The bituminous material shall conform to the applicable requirements of S-702. The type and grade of bituminous material will be specified in the contract. The grade may be changed one step by the Engineer at no change in unit price.

**S-408.03--Blotter Material.** Blotter material shall be sand-clay or other friable or near friable materials approved by the Engineer.

### **CONSTRUCTION REQUIREMENTS**

**S-408.04--Seasonal and Weather Limitations.** Bituminous material shall be applied only when permitted under the seasonal and weather limitations specified in S-410.07.

**S-408.05--Equipment.** The Contractor shall provide equipment for heating and applying bituminous material. Heating equipment and distributors shall meet the requirements of S-410.08.

**S-408.06--Preparation of Surface.** The surface to be primed shall be free from all ruts, corrugations, segregated material or other irregularities, and shall be conditioned as specified in S-410.09.

**S-408.07--Application of Bituminous Material.** The bituminous material shall be applied in accordance with applicable requirements of S-410.10.

**S-408.08--Application of Blotter Material.** The Contractor shall furnish and spread, without extra compensation, the minimum necessary quantity of approved blotter material over the prime coat.

**S-408.09--Maintenance.** The Contractor shall maintain the prime coat in a satisfactory condition until covered by subsequent construction. Maintenance shall include immediate repairs of all damage that may occur. All maintenance shall be performed at the expense of the Contractor, and shall be repeated as often as necessary to properly maintain the work.

**COMPENSATION**

**S-408.10--Method of Measurement.** Bituminous material will be measured by the gallon as specified in S-410.12. Blotter material will not be paid for separately but shall be included in the price bid per gallon for prime coat.

**S-408.11--Basis of Payment.** Prime coat will be paid for at the contract unit price per gallon as specified in S-410.13.

Payment will be made under:

**S-408-A:** Asphalt for Prime Coat ( \_\_\_\_\_ ) - per gallon  
Grade



**S-409.01--Description.** This work consists of furnishing and placing fabric underseal in accordance with the details shown on the plans and the requirements of these specifications. An underseal shall consist of an application of asphalt cement covered with a layer of fabric.

**S-409.02--Materials.**

**S-409.02.1--Geotextile Fabric.** The fabric shall meet the specific requirements for geotextile fabric underseal contained in S-714.13.4.

**S-409.02.2--Bituminous Material.** Unless otherwise designated, the asphalt sealant shall be asphalt cement Grade PG 64-22 meeting the applicable requirements of S-702.

**S-409.03--Construction Requirements.**

**S-409.03.1--Equipment.** The Contractor shall provide equipment for heating and applying bituminous material and for laying the pavement fabric. Heating equipment and distributors shall meet the requirements of S-410.

The mechanical fabric laydown equipment shall be capable of handling full rolls of fabric and shall be capable of laying the fabric smoothly without excessive wrinkles and/or folds. When manual laydown is required, a length of standard one inch pipe and suitable roll tension devices shall be used for proper roll handling. The fabric manufacturer or distributor shall furnish a technician to supervise installation of the fabric and training of Contractor's personnel.

**S-409.03.2--Surface Preparation.** The surface to be treated, and at least one additional foot on each side, shall be cleaned by sweeping, blowing, or other methods until all dust, dirt, mud, vegetation, and foreign materials are removed entirely from the pavement before the asphalt sealant is applied. Care shall be exercised to prevent material so removed from becoming mixed with subsequent courses.

**S-409.03.3--Application of the Asphalt Sealant.** The application of the asphalt sealant shall conform to the applicable requirements of S-410. The sealant shall be uniformly sprayed over the area to be covered by fabric at a rate recommended by the fabric manufacturer or distributor's technician and/or ordered by the Engineer. The rate of application is usually between 0.20 and 0.40 gallon per square yard. Varying surface conditions such as the degree of porosity of the existing pavement will cause varying application rates. The quantity applied shall be sufficient to bond and saturate the fabric, and to bond the subsequent overlay course to the fabric. Within intersections or other zones where vehicle braking is frequent, the application rate should be reduced. The sealant shall be applied to an area two to six inches wider than the width of fabric being placed, but restricted to the area of immediate fabric laydown.

Application shall be by distributor spray bar with hand hose spraying allowed only where the distributor spray bar cannot be used. Asphalt leakage from the distributor and any spillage shall be cleaned from the road surface to avoid flushing and possible fabric movement at these asphalt rich areas. The asphalt cement used as a sealant shall have distributor tank temperature between 300°F and 350°F, except when applying a tack coat to the fabric, the temperature shall not exceed 320°F to avoid damaging the fabric.

**S-409.03.4--Fabric Placement.** The fabric shall be placed on the asphaltic sealant as soon as practical and before the adhesion properties of the sealant is lost. The fabric shall be placed as smoothly as possible to avoid wrinkles.

Wrinkles severe enough to cause "folds" shall be slit and laid flat. Small wrinkles which flatten under compaction are not detrimental to performance. The fabric shall be broomed or squeegeed to remove air bubbles and make complete contact with the road surface as recommended by the fabric manufacturer or distributor. The fabric shall be laid straight, however moderate curves can be negotiated by stretching the fabric on the outside of the curve.

Longitudinal and transverse joints shall be made by overlapping the fabric at least six inches. Additional sealant shall be applied to the joints as required and may be applied by hand hose spraying or with mop and bucket if extreme care is taken to not over apply. Transverse joints should be "shingled" in the direction of construction traffic and paving to prevent pick-up. In circumstances where this method is impractical, asphalt pavement or sand spread over the joint will aid in prevention of pick-up.

When recommended by the manufacturer or distributor's technician and/or ordered by the Engineer, the fabric shall be rolled with a pneumatic roller to improve bonding and reduce slippage.

**S-409.03.5--Treatment of Fabric Prior to Overlay.** Normally it is not necessary to tack coat the fabric unless there are circumstances such as delay in placement of subsequent course, dust accumulation or insufficient initial application of sealant which would make tack coating desirable. If a tack coat is required by the Engineer, emulsified asphalt shall be applied at a rate of 0.02 to 0.05 gallon of residual asphalt per square yard.

Placement of the subsequent course shall closely follow fabric laydown. In the event that the sealant bleeds through the fabric, it may be necessary to blot the sealant with sand to prevent construction equipment from picking up the fabric. Turning of the paver and other vehicles must be gradual to avoid stripping or damage to the fabric.

If traffic must be maintained on the fabric prior to placement of the subsequent course, it is advisable to spread a small quantity of sand over the fabric and roll with a pneumatic roller to prevent tires from picking up the fabric.

If rain should cause a blistered appearance and bond loss, it shall be corrected by rolling with a pneumatic roller.

**S-409.03.6--Asphalt Pavement Overlay.** The overlay shall conform to S-401 and S-403 except that the mixture shall be delivered to the paver at a temperature of 275°F to 300°F. Temperature of the mix shall in no case exceed 325°F.

**S-409.04--Method of Measurement.** Geotextile fabric for underseal, placed in accordance with these specifications and as directed by the Engineer, will be measured by the square yard of surface area. Any overwidth of material installed and additional material required for laps will not be measured.

Asphalt cement for fabric underseal, applied in accordance with these specifications and as directed by the Engineer, will be measured by the gallon in accordance with S- 410.

Any blotting with sand, rolling to restore bond and application of a tack coat will not be measured for payment and is considered incidental to completion of the work.

**S-409.05--Basis of Payment.** Geotextile fabric for underseal will be paid for at the contract unit price per square yard. Asphalt cement for fabric underseal of the kind and grade specified, measured as provided above, will be paid for at the contract unit price per gallon. These prices shall be full compensation for satisfactorily completing the work.

Payment will be made under:

**S-409-A:** Geotextile Fabric for Underseal, Type   \*   - per square yard

**S-409-B:** Asphalt Cement for Fabric Underseal - per gallon

\* When not designated, see S-714.13.

**S-410.01--Description.** This work shall consist of the construction of a single or multiple layer bituminous surface treatment in accordance with these specifications and in reasonably close conformity with the lines shown on the plans or established by the Engineer.

### **MATERIALS**

**S-410.02--Bituminous Material.** The type and grade of bituminous materials will be specified in the contract and conform to the applicable requirements of S-702.

If any aggregate course is composed of gravel, an anti-strip agent shall be added to asphalt cement.

The type anti-strip agent used shall be on the latest LIST OF APPROVED SOURCES OF MATERIALS as furnished by MDOT and will be incorporated into the liquid asphalt cement at the refinery at the rate of application specified.

The anti-strip agent will not be paid for directly but compensation will be considered included in the prices bid for asphalt cement or aggregates.

**S-410.03--Cover Material.** Cover material shall meet the applicable requirements of S-703.14, and the type will be specified in the contract.

Only one type of aggregate or combination of aggregates shall be used on a particular project except with written permission of the State Aid Engineer.

Sites for stockpiles of cover material shall be grubbed and cleaned prior to storing the aggregates, and the ground shall be firm, smooth, and well drained.

**S-410.03.1--Blotter Material.** Blotter Material shall be sand-clay or other friable or near friable materials approved by the Engineer.

### **CONSTRUCTION REQUIREMENTS**

**S-410.04--Prime Coat.** The prime coat, when specified, shall meet the requirements of S-408.

During the period between the application of the prime coat and the bituminous surface treatment, the primed surface shall be kept in continuous repair. All holes, raveled areas, and areas deficient in prime shall be patched and repaired with approved materials.

**S-410.05--Blotter Material.** Blotter Material shall only be required if deemed necessary by the Engineer.

**S-410.06--Control of Traffic.** During the construction of each layer of bituminous surface treatment, the Contractor shall regulate the speed of his vehicles and other traffic in order that unnecessary damage to the course will be avoided.

**S-410.07--Seasonal and Weather Limitations.** Emulsified asphalt and cut-back asphalt shall be applied only when the air temperature is above 60°F. Asphalt cement shall be applied only when both the air and surface temperature is above 75°F.

Bituminous materials for the prime coat shall not be placed during the period between October 1 and March 1, nor when the weather is rainy or foggy.

Bituminous materials for Bituminous Surface Treatment shall not be placed during the period between October 15 and March 1, nor when the weather is rainy or foggy.

Bituminous materials for Re-seal shall not be placed during the period between October 1 and March 1, nor when the weather conditions are unfavorable for this type of construction.

On projects where completion of seal coats after October 15 or before March 1 is determined to be in the public interest, the State Aid Engineer may permit variations from the above under the condition that all the following requirements are met:

1. The air temperature is 60°F or higher.
2. Asphalt cement used is cut back with naphtha of the type that will yield from five to ten (5-10) percent off at 680°F when tested by method AASHTO T-78.
3. The naphtha is added at the refinery.
4. Aggregate is satisfactorily air dried in covered storage, or mechanically dried.
5. The sun is shining.
6. Aggregate is applied immediately behind the distributor.
7. No shot is made after mid-afternoon, and rolling is increased as directed for shots made after noon.
8. The Contractor retains full responsibility for the acceptable quality of the work within the intent of the contract, these conditions notwithstanding.
9. The work is performed under these modifications at no additional cost to the County.

Blanket authorization will not be given for use of the above modification, but will be given only when completion of the surface treatment would make the facility available for use by public traffic, or for subsequent construction.

Prior to October 15 and after March 1, when the requirements of these specifications are being met, but conditions are less than good for the adhesion of cover aggregate to the bituminous material, the Engineer may permit or require, at no additional cost to the County, the asphalt cement to be cut back with naphtha as previously indicated. Less than good placement conditions shall be understood to include, but not limited to: lower than desirable temperature; higher than desirable humidity; surface dampness; or coolness of the foundation or aggregate. Such undesirable conditions will occur, and therefore, these measures must be taken considerably earlier in the more northern portions of the State.

**S-410.08--Equipment.** The following or equivalent shall be furnished:

**S-410.08.1--Bituminous Heating Equipment.** This equipment shall heat and maintain the bituminous material within specification requirements without damaging the material. The heating equipment shall be supplied with at least one accurate asphalt thermometer.

**S-410.08.2--Distributor.** The distributor shall be mounted on pneumatic tires of sufficient width to prevent breaking the surface bond when the tank is fully loaded. It shall be self-propelled and sufficiently powered to maintain the desired speeds during operation. It shall be equipped to evenly heat and maintain the material at the required temperature; have adequate pressure devices and suitable manifolds to provide constant and even distribution for the entire length of the spray bars; and have positive cutoff to prevent dripping from the nozzles. It shall be so constructed that uniform applications may be made at the specified rate on variable widths up to twenty-six (26) feet. Charts and devices shall be provided by the Contractor for determining the quantity being applied.

**S-410.08.3--Rotary Brooms.** Rotary brooms shall be constructed to permit the revolutions of the broom to be adjusted to its progression and to permit adjustment of the broom in relation to the surface. The broom bristles shall be stiff enough to sweep clean without injury to the surface.

**S-410.08.4--Power Rollers.** Steel-wheel rollers shall be self-propelled, rated at 5 to 8 tons, and shall have a weight of at least two hundred (200) pounds per inch of roller width. The rollers may be the three wheel type, but the tandem type is preferred.

Pneumatic rollers shall be self-propelled with wheels mounted on two axles in such a manner that the rear tires will not follow in the tracks of the forward group. The rollers shall be capable of applying a minimum of fifty (50) pounds per square inch contact pressure under each tire, and shall be of a weight that will not damage the base or surface treatment.

**S-410.08.5--Trucks.** Trucks of sufficient number and size to adequately supply the material shall be furnished.

**S-410.08.6--Aggregate Spreaders.** Aggregate spreaders shall be self-propelled and constructed so that they can be accurately gauged and set to uniformly distribute the required quantity of aggregate at regulated speed.

**S-410.08.7--Other Equipment.** Drag brooms and blowers shall be furnished and used as conditions dictate.

**S-410.09--Preparation of Surface.** The entire surface to be treated and at least one foot on each side shall be cleaned by sweeping, blowing, or other methods until all dust, mud, clay lumps, and foreign material is removed. A primed base shall be properly cured and approved prior to application of bituminous material.

Testing requirements for Hot Mix Asphalt used for patching, base repair or leveling prior to reseal shall apply except as follows:

- A. The requirement for field densities is hereby waived for Hot Mix Asphalt used for patching, base repair and leveling on reseal projects. The Contractor shall be required; however, to maintain a compactive effort as directed by the Engineer.
- B. Mix designs or transfer of mix designs shall not be required for Hot Mix Asphalt (HMA) furnished by approved sources (plants currently supplying HMA for MDOT and/or State Aid projects).
- C. The Contractor shall submit certification to the Engineer that the source of HMA has been inspected and currently approved to supply HMA to MDOT and/or State Aid projects. In addition, form TMD 042 or equal, shall be furnished to the Engineer from each source and type mix incorporated into the project.
- D. Certificate A or B shall continue to be required for asphalt cement or emulsion and the material tested at the required frequencies noted in State Aid's latest edition of its Standard Operating Procedures (SOP's).

**S-410.10--Application of Bituminous Material.** Bituminous material shall not be applied until the prepared surface has been approved by the Engineer. Where practicable, shots shall be at least five hundred (500) feet in length, and longer shots are desirable. No shot shall be in excess of a length which can be covered with aggregate before the bitumen hardens.

The bituminous material shall be uniformly heated and maintained within the specified temperature range during application. All material damaged by heating shall be rejected, and if a section has been treated with damaged material it shall be removed and replaced by the Contractor without additional compensation.

The bituminous material shall be applied with a pressure distributor at the specified rate, and at the temperature specified by the Engineer within the range set out in S-702.12. It shall be uniformly applied at a width no wider than can be covered by one pass of the aggregate spreader or full width may be applied if the Contractor elects to use two aggregate spreaders. The application rate may be varied by the Engineer within the ranges set out in Table 410-A.

The application shall be stopped before the distributor is completely empty, and the length of shots shall be computed so that the application is stopped before it begins to run light. At all startings, including joints with preceding applications, intersections, and junctions with all pavements, etc., the distributor nozzles shall be operating at full force when the application begins. Building paper or other suitable material shall be used to receive the initial application from the nozzles before the asphalt reaches the road surface at the joint. The material used at the joint shall be removed immediately after use without spilling asphalt on the road surface.

Spray bar nozzles shall be kept clean at all times, and should one become blocked during application of the bituminous material, the distributor shall be stopped immediately and the nozzle cleaned before proceeding. Bare or light areas shall be immediately made uniform by use of a hand hose or pouring pot.

Due to possible spillage, the transfer of material from the delivery truck to the distributor shall be outside the limits of the roadway. Bituminous material shall not be discharged on the right-of-way when cleaning out the distributor. Any spillage shall be removed from the roadway and right-of-way.

During application of bituminous material, the Contractor shall provide adequate protection to prevent marring or discoloration of pavements, structures, curbs, trees, etc., adjacent to the area being treated.

Longitudinal joints shall be reasonably true to line and parallel to the centerline. The overlap in the application of the bituminous material shall be the minimum to assure complete coverage.



At construction joints, the treatment of the edges shall be blended so that there are no gaps; the elevations are the same; and the joints are free from ridges and depressions.

**S-410.11--Application of Cover Coat Material.** The application of cover material shall immediately follow the application of bituminous material. Adhesion of the cover aggregate to the bitumen is the Contractor's responsibility. The time interval between applications of bituminous material and cover aggregate shall not exceed 20 minutes when the air temperature is below 85°F or 30 minutes when the temperature is 85°F or above.

Aggregate shall be spread directly from approved spreaders. Trucks or spreaders shall not drive on the uncovered bituminous material.

The application rate of cover aggregate will be specified by the Engineer within the ranges set out in Table 410-A. The dry aggregate shall be spread uniformly to cover the bituminous material with the quantity of mineral aggregate specified by the Engineer. All deficient areas shall be covered with additional material. All excess cover material shall be removed from the surface and stockpiled or used as directed.

If needed, approved drag brooms and hand brooms shall be used to distribute the aggregate uniformly before and while rolling operations are in progress.

The entire application of aggregate shall be rolled as soon as possible after application. Rolling shall be continued and repeated as often as necessary to key the cover material thoroughly into the bituminous material over the entire surface.

Pneumatic-tire rollers and steel-wheel rollers shall be used in the sequence that will provide the rolling pattern that results in the best adhesion of the aggregate to the bituminous material and the best surface qualities.

Subsequent to the initial application of the aggregate the Contractor shall distribute, as many times as is deemed necessary, loose aggregate over the surface to absorb free bituminous material and to cover areas deficient in aggregate. Immediately following each distribution, the Contractor shall roll the entire surface treatment or seal with a pneumatic-tire roller until the maximum quantity of aggregate is embedded in the bitumen. Rolling in each case shall be at least one complete coverage and as many additional coverages as necessary to properly embed the aggregate. All rolling shall be performed while the temperature is favorable for sealing the aggregate into the bitumen.

In all cases there shall be at least five complete coverages of the entire surface of the treatment with a pneumatic-tire roller.

For variable application treatments or seals when the Engineer has determined that the maximum quantity of aggregate has been embedded on the first and/or second layer, the Contractor shall sweep or otherwise remove all excess material but not displace any embedded aggregate.

Maintenance of the surface shall include the distribution of cover aggregate over the surface to absorb any free bituminous material and to cover any deficient areas. Maintenance shall be conducted so as not to displace imbedded material. Excess Seal Aggregate shall be swept from the entire surface by rotary brooms prior to acceptance of work.

**S-410.11.1--Stress Relief Layers.** The application rates of bituminous material and cover aggregate for single surface treatment placed on an existing pavement as an interlayer below hot mix asphalt shall be as shown on the plans or directed. As soon as the single surface treatment has been applied and satisfactorily rolled, a thin (minimum cover) layer of hot mix asphalt leveling course (unless otherwise shown on the plans) shall be placed immediately in order to retain all aggregate of the surface treatment. Compaction of the hot mix asphalt layer shall consist of a minimum of three complete coverages with the pneumatic-tire roller. The steel-wheel roller will not be required and no formal density tests will be made. The quantity of hot mix asphalt mixture acceptably used in the layer will be included in measurement for leveling course. Seasonal and temperature limitations will not apply to this type of surface treatment.

**S-410.11.2--Maintenance.** The Contractor will be required to properly maintain that portion of the highway surface covered by his contract until relieved of such responsibility by the Engineer and in no case shall such period of maintenance be less than fourteen (14) days after the application of the seal course.

### **COMPENSATION**

**S-410.12--Method of Measurement.** Accepted bituminous material will be measured by the gallon in accordance with S-109. Unless otherwise specified, distributor tank measurement will be used. The volume of material over five percent above the quantity ordered for each shot will be deducted from measured quantities, except that fifteen (15) percent will be allowed for irregular areas where hand spraying is necessary.

Cover material and blotter material will be measured in cubic yards, (LVM) at the point of delivery on the road. Measurement will be for the actual volume spread. The volume of material over five percent above the quantity ordered for each "spreading" will be deducted from measured quantities, except that 15 percent will be allowed for irregular areas where hand spreading is necessary.

The volume of all cover material and the volume of all bituminous material lost, wasted, damaged, or rejected, or applied outside of designated areas, or in excess of the Engineer's directions and tolerances allowed, or contrary to the specifications, will be deducted from measured quantities.

**S-410.13--Basis of Payment.** Bituminous material will be paid for at the contract unit price per gallon. Cover material and blotter material will be paid for at the contract unit price per cubic yard (LVM).

Work performed and measured as specified above will be paid for under the applicable pay items set out below for the specific type of work specified in the proposal and shall be full compensation for completing the work

Payment will be made under:

- S-410-A:** Asphalt Cement, Grade\_\_\_\_\_ - per gallon
- S-410-B:** Cutback Asphalt, Grade\_\_\_\_\_ - per gallon
- S-410-C:** Emulsified Asphalt, Grade\_\_\_\_\_ - per gallon
- S-410-C-1:** Polymerized-Emulsified Asphalt, Grade CRS-2P - per gallon
- S-410-D:** Coarse Aggregate Cover Material, Size\_\_\_\_\_, Type\_\_\_\_\_ - per cubic yard
- S-410-E:** Seal Aggregate Cover Material, Size\_\_\_\_\_, Type\_\_\_\_\_ - per cubic yard
- S-410-F:** Blotter Material - per cubic yard

**TABLE 410-A - BITUMINOUS SURFACE TREATMENTS**

TYPE	PAY ITEM	Bituminous Material	gallons per square yard	Coarse Agg. Cover Coat Material cubic feet per square yard	Seal Agg. Cover Material cubic feet per square yard
Prime Coat	S-408	RC-70, 250; MC-30, 70, 250; EA-1	0.15-0.50	None	None
Tack Coat	S-407	RC-70, 250, 800; RS-1, 2; SS-1, SS-1h; AC Same as Mix; CSS-1, CSS-1h	0.05-0.10	None	None
<b>SINGLE APPLICATION BITUMINOUS SURFACE TREATMENT</b>					
SBST	S-410	AC-5, 10; RC-800; RS-1, 2; CRS-2, 2P			
or	Alt. No. 1S		AC = 0.36 - 0.42 RC, RS, or CRS = 0.47 - 0.52	Size 5, 56 or 6 (Slag or Stone) as specified 0.52 - 0.56	None
	Alt. No. 2S		AC = 0.34 - 0.40 RC, RS, or CRS = 0.42 - 0.47	Size 5 or 6 (Gravel) as specified 0.48 - 0.54	None
	Alt. No. 3S		AC = 0.25 - 0.35 RC, RS, OR CRS = 0.39 - 0.44	None	Size 7, 8, or 89 (Slag, Stone, Gravel or Exp. clay) as specified 0.25 - 0.31

**TABLE 410-A - BITUMINOUS SURFACE TREATMENTS--CONTINUED:**

TYPE	PAY ITEM	Bituminous Material	gallons per square yard	Coarse Agg. Cover Coat Material cubic feet per square yard	Seal Agg. Cover Material cubic feet per square yard
<b>DOUBLE APPLICATION BITUMINOUS SURFACE TREATMENT</b>					
DBST	S-410	AC-5, 10; RC-800; RS-1, 2; CRS-2, 2P			
or	Alt. No. 1D	1st Course	AC = 0.36 - 0.42 RC, RS or CRS = 0.44 - 0.49	Size 5, 6 or 56 (slag or stone) as specified 0.50 - 0.54	
		2nd Course	AC = 0.27 - 0.40 RC, RS or CRS = 0.39 - 0.47		Size 7, 8, or 89 (slag or stone, gravel, Exp. clay) as specified 0.25 - 0.31
	Alt. No. 2D	1 Course	AC = 0.30 - 0.38 RC, RS or CRS = 0.42 - 0.47	Size 5 or 6 (Gravel) Mod. as specified 0.48 - 0.54	
		2 Course	AC = 0.27 - 0.40 RC, RS or CRS = 0.39 - 0.47		Size 7, 8 or 89 (slag, stone, gravel, Exp. clay) as specified 0.25 - 0.31

**TABLE 410-A - BITUMINOUS SURFACE TREATMENTS--CONTINUED:**

TYPE	PAY ITEM	Bituminous Material	gallons per square yard	Coarse Agg. Cover Coat Material cubic feet per square yard	Seal Agg. Cover Material cubic feet per square yard
<b>*TRIPLE BITUMINOUS SURFACE TREATMENT</b>					
TBST	S-410	AC-5, 10; RC-800; RS-1, 2; CRS-2, 2P			
		3rd Course	AC = 0.14 - 0.19 RC, RS or CRS = 0.18 - 0.25		Size 89** (slag, stone, gravel or Exp. clay) as specified 0.13 - 0.18

**\*NOTE:** The first two courses when triple bituminous surface treatment is specified shall be placed as indicated above for DBST.

**\*\*NOTE:** The type aggregate used for the third course of TBST shall be the same as the type aggregate used in the second course.

**S-411.01--Description.** This work consists of a bituminous slurry surface composed of either a mixture of cationic emulsified asphalt, mineral aggregate, mineral filler, fiber additives when specified and water, or a quick-set polymer modified cationic emulsion, a blend of crushed mineral aggregate, mineral filler liquid additive and water, properly proportioned, mixed, and spread evenly on the surface as specified herein and as directed, and in accordance with these specifications. The cured slurry shall have a homogeneous appearance, adhere firmly to the surface and have a skid resistant texture.

Polymer modified slurry seal shall be one from Mississippi Department of Transportation's List of Approved Materials. When Types 2 or 3 are specified, polymer modified slurry seal may be used as an alternate at no additional cost to the project.

**S-411.02--Materials.**

**S-411.02.1--General.** All materials shall be pretested to determine their suitability for use in slurry mix and their compliance with the applicable specifications prior to their use. The mix design shall be prepared by an approved laboratory. It shall be the responsibility of the Contractor to furnish a mix design that will produce the desired results. The actual emulsion and aggregates in the proportions to be used on the job shall make a compatible and homogeneous mixture. Samples of all materials proposed to be used in the job-mix shall be submitted to the testing laboratory at least 30 days prior to the date of intended placement. The Engineer shall have final approval of the rate of application used.

**S-411.02.2--Emulsified Asphalt.** Unless otherwise specified, emulsified asphalt shall be Grade CQS-1h meeting the following requirements:

**(a) TESTS ON EMULSION**

Viscosity, Saybolt-Furol-	
60 ml. at 77°F, sec.....	20-100
Residue by distillation, % minimum.....	60
Sieve, % retained # 20 mesh, maximum.....	0.10
pH, maximum.....	5.5
Particle Charge.....	Positive
Slurry mixing test (c).....	Pass
Slurry setting test (d).....	1 hr. max.

**(b) TESTS ON RESIDUE**

Penetration at 77°F, 100 grams, 5 sec.....40-90  
 Solubility in Trichloroethane, % minimum.....97  
 Ductility at 77°F, centimeters, minimum.....40

**(c) SLURRY MIXING TESTS**

The aggregate shall be normal job aggregate with sieve size appropriate for slurry seal application. To this aggregate is added 1% by weight portland cement. To 200 grams of this aggregate is added sufficient water to yield a well wetted stone. To this wetted aggregate is then added 15% by weight CQS-1h emulsified asphalt. This mixture shall be capable of forming a free-flowing, smooth, creamy, homogeneous slurry with hand stirring (spoon or spatula) for a period not to exceed two minutes mixing time.

**(d) SLURRY SETTING TEST**

The above mix, when spread out on a section of asphaltic saturated roofing felt to a thickness of approximately 1/4 inch, shall be dry to the touch in one hour at 75°F minimum temperature and a relative humidity of 35% to 65%.

**S-411.02.3--Polymer Modified Emulsified Asphalt.** Prior to addition of the polymer, the cationic emulsified asphalt may be Grade CSS-1h meeting the requirements of AASHTO Designation: M 208 or Grade CQS-1h meeting the requirements of S-411.02.2. In addition, the polymer modified emulsion shall meet the slurry mixing and slurry setting tests as set out in S-411.02.2 and the following requirements:

Test of Residue:

Penetration @ 77°F	30 minimum
Ductility @ 77°F	70 minimum
Softening Point, Ring & Ball °C	55 minimum

The polymer shall be combined with the asphalt emulsion in the manufacturing process or by the refinery prior to shipment.

The cement mixing test shall be waived for this emulsion.



**S-411.02.4--Aggregate.** Mineral aggregate shall consist of limestone, granite, slag, or a combination thereof. The aggregate shall be clean and free from vegetable matter and other deleterious substances and shall have a percent of wear by Los Angeles Test (AASHTO T 96) not greater than 35. When required by job conditions, the amount of mineral filler shall not exceed 2% of the dry aggregate by weight.

Aggregate samples will be tested for gradation in accordance with AASHTO Designations: T 11, T 27, T 30, as applicable.

**S-411.02.5--Fiber Additives.** Fiber additives, when used, shall be a short length polypropylene or other approved fibers designed especially for highway asphalt application. Polypropylene fiber must equal or exceed Hercules Fiber Pave 4010 or an approved equal in flexibility, surface modification, length, diameter, chemical resistance and tensile strength.

**S-411.02.6--Water.** All water used with the slurry seal mixtures shall be potable and free from harmful soluble salts.

**S-411.02.7--Portland Cement.** Portland cement added for dispersion of the slurry seal shall be of commercial quality, non-air entraining and shall not be considered as mineral filler for the purpose of satisfying the gradation requirements of aggregate.

**S-411.02.8--Mineral Filler.** Mineral filler shall meet the requirements of S-703.16.

**S-411.02.9--Composition.**

**S-411.02.9.1--Standard Slurry Seal Surface.** These slurry seals shall be composed of a mixture of mineral aggregate, fiber additives when specified, and emulsified asphalt. The proportions by weight for the mixture shall be as set out in the following table:

**PERCENT PASSING**

<b>Sieve Size</b>	<b>Type 1</b>	<b>Type 2</b>	<b>Type 3</b>
3/8 inch	100	100	100
No. 4	100	85-100	70-95
No. 8	100	65-90	45-70
No. 16	65-90	45-70	30-50
No. 30	40-60	30-50	20-35
No. 50	25-42	18-30	12-25
No. 100	15-30	10-21	7-18
No. 200	10-20	7-15	5-12
Residual Asphalt			
% Dry Aggregate	5.0-12.0	5.0-12.0	5.0-12.0
Fiber Additives (When Specified)			
% Dry Aggregate		0.3-0.5%	

The quantity of emulsified asphalt to be blended with the aggregate shall be that as determined by the laboratory resulting in a residual asphalt content within the above limits. The Engineer will approve a job mixture within the above limits. A minimum quantity of water shall be added as necessary to produce a fluid and homogeneous mixture of the proper consistency.

**S-411.02.9.2--Polymer Modified Slurry Surface Seal.** Polymer modified slurry seal shall be composed of a mixture of mineral aggregate, polymer modified cationic emulsion and other additives as required to control the quick-set properties in the following proportions by weight:

**PERCENT PASSING**

Sieve Size	Type 4	Type 5
3/8 inch	100	100
No. 4	85-100	70-95
No. 8	65-90	45-70
No. 16	45-70	30-50
No. 30	30-50	20-35
No. 50	18-30	12-25
No. 100	10-21	7-18
No. 200	7-15	5-12
Residual Asphalt % Dry Aggregate	5.0-12.0	5.0-12.0

**NOTE: Type 5 is for use Primary and Interstate Routes.**

A minimum quantity of water and other additives shall be added as required to produce a fluid and homogenous quick-setting mixture of the proper consistency.

**S-411.03--Construction Requirements.**

**S-411.03.1--Weather Limitations.** Work will not be permitted when the atmospheric temperature is less than 50°F. The mixture shall not be applied if high relative humidity prolongs the curing beyond a reasonable time. The protection of the slurry will be the responsibility of the Contractor. In case the fresh slurry is damaged by rain or any other cause, the slurry shall be replaced in a satisfactory manner at the Contractor's expense.

**S-411.03.2--Construction Details for Standard Slurry Seal.**

**S-411.03.2.1--Equipment.**

**S-411.03.2.1.1--General.** All equipment, tools, and machines used in the performance of this work shall be maintained in satisfactory working condition.

**S-411.03.2.1.2--Mixer.** The slurry seal mixing machine shall be a continuous flow mixing unit capable of delivering accurate predetermined proportions of aggregates, mineral filler, water, and emulsified asphalt to the mixing chamber and discharging the thoroughly mixed product on a continuous basis at the uniform rate required for the area being covered by the spreader. The aggregate and mineral filler shall be prewetted in the mixer immediately prior to mixing with the emulsified asphalt. Mixing shall be done in a manner that does not cause premature breaking of the emulsified asphalt. The mixing unit of the mixing chamber shall be capable of thoroughly blending all ingredients. Sufficient material storage shall be provided to enable the machine to apply a minimum of five tons of aggregate without recharging the aggregate bins.

The mixing machine shall be equipped with an approved fines feeder that has an accurate metering device or method to introduce a predetermined amount of mineral filler into the mixer at the same time and location as the mineral aggregate.

The mixing machine shall be equipped with a water pressure system and fog type spray bar, adequate for complete fogging of the surface preceding spreading equipment of the slurry mixture.

The mixing machine shall include controls for proportioning and calibrating the aggregate feed. The aggregate feed device shall be equipped with a revolution counter so that the amount of aggregate used may be determined at any time.

The emulsion pump shall be of the positive displacement type and shall be equipped with a device that will indicate the amount of emulsion used. The emulsion pump, indicating device and piping shall be arranged to afford a means to calibrate the indicating device by weighing a metered volume. The pump shall deliver the asphalt to the mixer box at a uniform rate.

The water pump shall be equipped with a minimum of two valves. One valve shall establish the required water flow. The other valve shall be a quick acting valve to start and stop the water flow.

Satisfactory means shall be provided to afford positive interlocking control between the flow of aggregate from the bins and the flow of emulsion from the pump. This control shall be accomplished by interlocking mechanical means or by any positive method under the Engineer's control. The Contractor shall provide the necessary equipment and personnel to assist the Engineer in calibrating the slurry machine.

When slurry with fibers is specified, the mixing machine shall be equipped with an approved fiber metering device that is mechanically interlocked with the feed system of the machine. An auger type feeding unit is preferred.

The metering device must maintain an accuracy of  $\pm 0.05\%$  over the operating range of the machine. Under no circumstances will the fiber be premixed with the aggregate prior to introduction of the aggregate into the mixer, nor shall it be introduced into the mixer in a dry state; i.e., without being chemically treated.

The fibers shall be chemically treated prior to loading into the fiber metering device on the slurry machine. Chemical treatment shall consist of coating the fibers with suitable chemicals such as Hercules CMC and Naturasol or equal in a water based solution without violent mixing.

**S-411.03.2.1.3--Spreading Equipment.** Attached to the mixer machine shall be a mechanical adjustable type squeegee distributor equipped with flexible material in contact with the surface to prevent loss of slurry from the distributor. It shall be maintained so as to prevent loss of slurry on varying grades and crown by adjustments to assure uniform spread and shall have a flexible and adjustable strike-off. It shall be equipped with a hydraulic cylinder, controlled by the operator, which provides lateral movement of the spreader box. The distributor shall be equipped with augers to provide uniform distribution of slurry on any roadway cross-section.

A light drag of burlap or similar material covered by polyethylene strips shall be dragged behind the laying box in order to produce a longitudinal belted surface. This drag shall be of such dimension and weight and shall be so operated as to avoid producing deep grooves in the surface. This drag shall either be kept clean or shall be replaced as often as necessary to produce a satisfactory surface.

Use of burlap drags or other drags necessary to obtain the desired finish shall be approved by the Engineer.

**S-411.03.2.1.4--Auxiliary Equipment.** Hand squeegees, shovels, and hand equipment shall be provided as necessary to perform the work.

**S-411.03.2.2--Preparation of Surface.** Immediately prior to applying the slurry seal, the surface shall be cleaned of all loose material, silt spots, vegetation, and other objectionable material.

**S-411.03.2.3--Application of Standard Slurry Seal Coat.** The surface shall be fogged with water directly preceding the spreader at a rate such that the entire surface shall be damp. The slurry mixture shall be of the desired consistency when deposited on the surface and no additional elements shall be added. Total time of mixing shall not exceed four minutes. A sufficient amount of slurry shall be carried in all parts of the spreader at all times so that complete coverage is obtained. The maximum allowable speed of the machine shall be 140 feet per minute. The application rate of the slurry shall be that required to obtain a dry surface thickness of 1/4 to 3/8 inch.

Approved squeegees shall be used to spread slurry in areas not accessible to the slurry mixer.

Excess build up of slurry on longitudinal or transverse joints will not be permitted. Longitudinal laps should not exceed six inches in width and shall be along the centerline or as directed by the Engineer, so that a lapped joint will correctly delineate the traffic lanes.

Treated areas shall be allowed to cure until such time as the Engineer permits their opening to traffic.

When used as an interlayer, no subsequent course shall be placed until the slurry seal has been in place for a sufficient period of time, as determined by the Engineer, to properly dry and cure. Under conditions where the slurry seal surface is not exposed to traffic for at least 48 hours, the Engineer may require that the surface be rolled with a pneumatic roller.

### **S-411.03.3--Construction Details for Polymer Modified Slurry.**

#### **S-411.03.3.1--Equipment.**

**S-411.03.3.1.1--General.** All equipment, tools, and machines used in the performance of this work shall be maintained in satisfactory working condition at all times to ensure a high quality product.

**S-411.03.3.1.2--Mixing Equipment.** The paving mixture shall be produced in a self-propelled, front feed, continuous loading, mixing machine equipped with a chain-dragged conveyor belt aggregate delivery system and an interconnected positive displacement water-jacked gear pump to accurately proportion ingredients. A spray bar shall be provided to completely wet the aggregate dropping down to the pugmill with additive and water. The twin-shafted multi-blade pugmill shall be a continuous-flow type and a minimum of fifty (50) inches long. The emulsion shall be introduced above the third point of the mixer to ensure proper pre-mixing of the aggregate, cement, additive and water when the modified emulsified asphalt is added. Blade size and side clearances shall meet the equipment manufacturer's recommendations. Mixer shall be equipped with a remote forward speed control at the back mixing platform so the back operator can control forward speed and level of mixture in paving or rutbox. Contractor shall provide material control devices that are readily accessible and positioned so the amount of each material used can be determined at any time. Each material control device shall be calibrated prior to each mix application.

Mixing machine shall be equipped with a water pressure system and nozzle type spray bar to provide a water spray ahead of and outside the spreader box when required.

Mineral filler feed shall be located so the proper amount of mineral filler is dropped on the aggregates before discharge into the mixer.

Truck-mounted machines with a positive, non-slipping aggregate delivery system and without the front feed, continuous loading feature may be used on project segments of less than 15,000 square yards or spot repair projects.

**S-411.03.3.1.3--Proportioning Devices.** Individual volume or weight controls for proportioning each material to be added to the mix, i.e., aggregate, emulsified asphalt, mineral and field control additives, and water shall be provided and properly marked. These proportioning devices are usually revolution counters or similar devices and are used in material calibration and determining the materials output at any time.

**S-411.03.3.1.4--Emulsion Pump.** The emulsion pump shall be a heated positive displacement type.

**S-411.03.3.1.5--Auxiliary Equipment.** Suitable crack and surface cleaning equipment, traffic control equipment, hand tools and any support equipment shall be provided as necessary to perform the work.

**S-411.03.3.1.6--Spreading Equipment.** The paving mixture shall be spread uniformly by means of a mechanical type squeegee box, attached to the mixer, equipped with paddles mounted on adjustable shaft to continually agitate and distribute the materials throughout the box. The equipment shall provide sufficient turbulence to prevent the mix from setting in the box or causing excessive side build-up or lumps. To prevent loss of the mixture from the box, the Contractor shall attach flexible seals, front and rear, in contact with the road. Rut filling will require a steel strike-off on the spreading equipment. The Contractor shall operate the spreading equipment in such a manner to prevent the loss of the mixture on superelevated curves. Mixture shall be spread to fill cracks and minor surface irregularities and achieve a uniform skid-resistant surface without causing skips, lumps, or tears in the finished surface.

**S-411.03.3.1.7--Machine Calibration.** Each mixing unit to be used in performance of the work shall be calibrated in the presence of the Engineer prior to construction, or previous calibration documentation covering the exact materials to be used may be acceptable provided they were made during that calendar year. The documentation shall include the individual calibration of each material at various settings, which can be related to the machine metering devices.

**S-411.03.3.2--Surface Preparation.**

**S-411.03.3.2.1--General.** The area to be surfaced shall be thoroughly cleaned of vegetation, loose aggregate and soil, particularly soil that is bound to the surface. Manholes, valve boxes and other service entrances will be protected from the surfacing material.

**S-411.03.3.2.2--Cracks.** All cracks greater than 1/4 inch shall be sealed with an approved joint sealer prior to application of the surfacing.

**S-411.03.3.2.3--Tack Coat.** When specified, a tack coat of the same grade emulsified asphalt as used in the paving mixture shall be applied at the rate specified on the plans.

**S-411.03.3.2.4--Stockpile.** Precautions shall be taken to insure that stockpiles do not become contaminated. The mineral aggregate shall be screened prior to being weighed for job site delivery. This weighing shall be done by means of a scale approved by the Engineer.

**S-411.03.3.3--Application.**

**S-411.03.3.3.1--General.** The surface shall be pretreated by fogging ahead of the spreader box when required by local conditions. The rate of application of the fog spray shall be adjusted during the day to suit temperatures, surface texture, humidity, and dryness of the pavement surface.

The surfacing mixture shall be of the desired consistency upon leaving the mixer and no additional material shall be added. A sufficient amount of material shall be carried in all parts of the spreader at all times so that a complete coverage is obtained. Overloading of the spreader shall be avoided. No lumping, balling, or unmixed aggregate will be permitted.

No streaks, such as those caused by oversized aggregate, will be left in the finished surface. If excessive oversize develops, work shall be suspended until the Contractor proves to the Engineer that the situation has been corrected.

When transitions are included as part of the polymer modified slurry seal work, then these areas are to be surfaced prior to application of the main traffic lines. This shall include intersections, turnouts, radii, ramps, etc.

All work in those areas adjacent to the main traffic line where the use of the lay down machine is not possible shall be performed by hand as a single course application prior to placing the finished application in the main traffic line.



**S-411.03.3.3.2--Joints.** No excessive buildup, uncovered areas or unsightly appearances shall be permitted on longitudinal or transverse joints. The Contractor shall provide suitable width spreading equipment to produce a minimum number of longitudinal joints throughout the project. When possible longitudinal joints shall be placed on lane lines. Half passes and odd width passes will be used only in minimum amounts. If half passes are used, they shall not be the last pass of any paved area.

**S-411.03.3.3.3--Mix Stability.** The surfacing mixture shall possess sufficient stability so that premature breaking of the material in the spreader box does not occur. The mixture shall be homogenous during and following mixing and spreading. It shall be free of excess water or emulsion and free of segregation of the emulsion and aggregate fines from the coarser aggregate.

**S-411.03.3.3.4--Hand Work.** Areas which cannot be reached with the mixing machine shall be surfaced using hand squeegees to provide complete and uniform coverage. The area to be hand worked shall be lightly dampened prior to mix placement. Care shall be exercised to leave no unsightly appearance from hand work.

**S-411.03.3.3.5--Lines.** Care shall be taken to insure straight lines along curbs and shoulders. No run-off on these areas will be permitted. Lines at intersections will be kept straight to provide a good appearance.

**S-411.03.3.3.6--Multiple Courses.** Where multiple course applications are required the initial course shall be a "scratch" course with adequate material applied to fill all surface irregularities, with the exception of continuous wheel path ruts with rut depths in excess of 3/8 inch. The initial course on pavements with continuous wheel path ruts in excess of 3/8 inch shall be applied as a rut-fill application using a rut-fill box. The rut filling application shall be one rut per pass with a V-configuration rut-fill box specifically designed for rut-fill applications. The final course shall be the finished slurry seal application.

**S-411.03.3.4--Quality Control.** The Engineer will use the recorders and measuring devices of the unit to determine rate of application and mix composition.

**S-411.03.3.5--Certification.** The Contractor shall furnish a certification that the mixture meets the requirements of this specification and that the mixture is of the same composition as that originally approved by MDOT or other approved lab.

**S-411.03.4--Traffic Control.** All construction operations shall be scheduled and coordinated to result in the least inconvenience and the maximum safety to the traveling public. Traffic shall not be maintained on the slurry surface for more than 15 days prior to placement of the next course of required construction when used as an interlayer.

Adequate means shall be provided to protect the slurry from damage by traffic until such time that the mixture has cured sufficiently so that the slurry will not adhere to or be picked up by the tires of vehicles. Application of the slurry shall be suspended early enough each day to permit traffic to safely travel over the completed work before dark. Any damage to the slurry by traffic shall be repaired by the Contractor at the Contractor's expense.

**S-411.04--Method of Measurement.** Acceptable slurry, with or without fibers or polymer modified slurry, will be measured by the square yard of roadways, ramps, crossroads and turnouts covered by the slurry. Emulsified asphalt, pneumatic rolling, aggregates, water, mineral fillers, and portland cement (Type I) will not be measured for direct payment but shall be considered a necessary part of the slurry and its construction.

In lieu of measurement by the square yard, Slurry Seal may be measured by the ton of aggregate and gallon of emulsified asphalt. The aggregate may be weighed on scales meeting the requirements of S-401.03.2.1.11. The weight will be based on a 2000 pound ton and the aggregate weight corrected for moisture. Moisture corrections shall be performed as conditions warrant with a minimum of one per day. The emulsified asphalt shall be corrected for temperature in accordance with the State Aid SOP.

Adjustments for changes in cost of construction materials (fuels and asphalt) will not be made on slurry.

**S-411.05--Basis of Payment.** Slurry, with or without fibers, will be paid for at the contract unit price per square yard. The contract unit prices shall be full compensation for furnishing, loading, hauling, mixing, placing, rolling, and applying all materials; for all cleaning and sweeping; and for all labor, equipment, tools and incidentals necessary to complete the work.

In lieu of payment by the square yard, Slurry Seal will be paid for at the contract unit price bid per ton for aggregate and per unit price bid per gallon for emulsified asphalt of the type and grade specified, which shall be full compensation for furnishing all required materials, including mixing water, cement, and additives, and performing all operations necessary to complete the work.

Payment will be made under:

- S-411-A:** Slurry Seal (Type \_\_\_\_\_) - per square yard
- S-411-B:** Slurry Seal (Type \_\_\_\_\_) (With Fibers) - per square yard
- S-411-C:** Polymer Modified Slurry Surface Seal (Type \_\_\_\_\_) - per square yard
- S-411-D:** Aggregate for Slurry Surface Seal (Type \_\_\_\_\_) - per ton
- S-411-E:** Emulsified Asphalt (Grade \_\_\_\_\_) - per gallon

**Section S-412 - Blank.**

**S-413.01--Description.** This work consists of routing, sawing and/or cleaning, sealing joints and cracks in existing pavement as designated by pay items in the contract proposal and as detailed on the plans and described herein. All work shall be in reasonably close conformity with these specifications and the details shown on the plans, or as directed.

When called for on the plans, this work shall also consist of saw cutting, cleaning and sealing transverse joints in new bituminous concrete overlays. Bituminous concrete pavement joints shall be constructed over, and in line with, the existing underlying transverse portland cement concrete joints in accordance with plans, specifications, and as directed by the Engineer.

**S-413.02--Materials.** Unless otherwise designated on the plans or in the contract documents, the joint sealing material may be cold or hot poured material meeting the requirements of S-707.02.1.

The joint sealing material for sealing transverse joints in new bituminous pavement shall be a hot-poured elastic type conforming to the requirements of S-707.02.1.3. The bond breaker tape shall consist of regular masking tape or a suitable bond breaker tape designed for use with hot-poured sealants. The width of the tape may be equal to but not more than 1/8" narrower than the width of the saw cut.

Unless otherwise specified in the plans or in the contract documents, the aggregate materials shall be size 89. The aggregate material shall conform to the applicable requirements of S-703.

**S-413.03--Construction Requirements.**

**S-413.03.1--Equipment.** The equipment shall be that necessary for routing, sawing, cleaning and pouring the joint material as specified. When required, heating equipment shall meet the requirements of S-702.03. Pouring equipment shall be subject to the approval of the Engineer and shall be capable of pouring the joints and cracks to the required elevation while the material is at the proper temperature. Cleaning equipment shall consist of mechanical or hand operated devices capable of thoroughly cleaning the joints, cracks and adjacent surfaces to the satisfaction of the Engineer. Air compressors shall be equipped with suitable traps and/or filters capable of removing moisture and oil from the compressed air.

**S-413.03.2--Construction Methods.**

**S-413.03.2.1--Cleaning and Sealing Joints and Cracks.** Joints and cracks to be sealed shall be cleaned by routing, sawing and/or sand blasting to the minimum dimensions specified. Other methods of cleaning joints and cracks shall be approved by the Engineer. The surface which is to receive the new joint sealing material shall be dry and free of all lubricants, tar, asphalt, discoloration and stain as well as all other forms of contamination leaving a clean newly exposed surface. The adjacent surfaces of the pavement shall be cleaned to the extent necessary to prevent foreign matter from entering the joint before pouring. If necessary, re-cleaning shall be performed immediately prior to pouring.

Before pouring, suitable baffles shall be inserted in the top portion of the open joint, or other approved methods used as necessary, to control the flow of the material into the joint.

Should a joint or crack be deeper than the required dimension, a backer rod of the appropriate size shall be inserted into the opening to prevent the material from being placed in excess of the required depth.

Cracks shall be cleaned and sealed in the same manner as for joints. The Engineer may permit small cracks to be cleaned only by compressed air and sealed with joint sealing material.

Traffic shall not be allowed to travel over the sealed joints/cracks until the joint sealing material is dry enough to prevent tracking. When approved by the Engineer, the Contractor may place concrete sand or other approved material over the joint/crack to prevent tracking.

**S-413.03.2.2--Cleaning and Filling Joints.** Joints to be filled shall be cleaned by routing, sawing and/or sand blasting to the minimum dimensions specified. Other methods of cleaning joints shall be approved by the Engineer. The surface which is to receive the new joint sealing material shall be dry and free of all lubricants, tar, asphalt, discoloration and stain as well as all other forms of contamination leaving a clean newly exposed surface. The adjacent surfaces of the pavement shall be cleaned to the extent necessary to prevent foreign matter from entering the joint before pouring. If necessary, re-cleaning shall be performed immediately prior to pouring.

Before pouring, suitable baffles shall be inserted in the top portion of the open joint, or other approved methods used as necessary, to control the flow of the material into the joint.

Should a joint or crack be deeper than the required dimension, a backer rod of the appropriate size shall be inserted into the opening to prevent the material from being placed in excess of the required depth.

After the joint is filled to the required depth with joint sealing material, add aggregate material until the joint is even with the adjacent roadway.

Traffic shall not be allowed to travel over the sealed joints/cracks until the joint sealing material is dry enough to prevent tracking. When approved by the Engineer, the Contractor may place concrete sand or other approved material over the joint/crack to prevent tracking.

**S-413.03.3--Sawing and Sealing Transverse Joints in Asphalt Pavement.**

**S-413.03.3.1--General.** The Contractor's operation shall be conducted so that sawcutting of transverse joints, cleaning, and sealing is a continuous operation. The entire sawing and sealing operation shall be completed within seven (7) days after the placement of the final wearing course, unless the approved traffic control plan or sequence of operations provide otherwise. Traffic shall not be allowed on sawed unsealed joints. When intermediate lifts must be exposed to traffic for over seven (7) days, the

Contractor shall be required to make an interim 1/8-inch wide saw cut which is one third (1/3) as deep as the hot mix asphalt layer. This interim saw cut does not require sealing. Costs of this interim cut(s) is to be absorbed the pay item for sawing and sealing transverse joints in asphalt pavement.

Saw cutting shall be done only after the hot mix asphalt has cooled to ambient temperature.

**S-413.03.3.2--Sawcutting of Transverse Joints.** The Contractor shall sawcut transverse joints in the pattern and to the dimensions shown on the plans or as directed by the Engineer. The sawcut joints shall be directly over the existing portland cement concrete pavement joints and shall be accurately located by a method employing pins and stringline. The pins shall be accurately located prior to paving. Details of the Contractor's method for locating the sawcuts shall be subject to the approval of the Engineer.

The blade or blades shall be of such size and configuration that the desired dimensions of each sawcut can be made with one pass. No spacers between blades will be allowed. Either dry or wet cutting will be allowed.

The transverse sawcut joints shall normally extend the full width of the pavement unless otherwise shown on the plans or directed by the Engineer. Existing transverse joints that are offset at the longitudinal joint by more than one inch, measured between the centers of the joint cavities, shall require separate sawcuts terminating at the longitudinal joint.

**S-413.03.3.3--Cleaning.** Dry sawed joints shall be thoroughly cleaned with a stream of air sufficient to remove dirt, dust or deleterious matter adhering to the joint walls or remaining in the joint cavity. Wet sawed joints shall be thoroughly cleaned with a 50 psi minimum, water blast immediately after sawing to remove any sawing slurry, dirt or deleterious matter adhering to the joint walls or remaining in the joint cavity. Wet sawed joints shall be blown with air to provide dry joint surfaces prior to sealing.

All sawing slurry from the wet sawing process shall be immediately flushed from the pavement surface. Dry dust and material from the dry sawing process shall be blown or brushed off the pavement surface.

The Contractor shall be required to provide protective screening, subject to the approval of the Engineer, if cleaning operations are capable of causing damage to or interference with traffic in adjacent lanes.

**S-413.03.3.4--Sealing.** Just prior to sealing, each joint shall be thoroughly cleaned of all foreign material and the joint faces shall be clean and surface dry when the seal is applied.

After cleaning, and just prior to sealing, a bond breaker tape shall be placed in the bottom of the sawcut joint.

Sealant material shall be at the pouring temperature recommended by the manufacturer when applied to the joints. Hot applied sealant material shall be stirred during heating so that localized overheating does not occur.

The sealant shall fill the joint such that, after cooling, the sealed joint conforms to the details shown on the plans or as directed by the Engineer. The pouring shall be performed in such a manner that the material will not be spilled on the exposed surfaces of the asphalt pavement. Any excess material on the surface of the asphalt pavement shall be removed immediately and the pavement surface cleaned. The use of sand or similar material as a cover for the seal will not be permitted. Poured joint sealing material shall not be placed when the air temperature in the shade is less than 50°F., unless approved by the Engineer.

**S-413.04--Method of Measurement.** Joint sealer material will be measured by the gallon for separate payment only when the proposal has a pay item for joint material.

Accepted joints and cracks, cleaned, sealed and/or filled, will be measured by the linear foot as indicated in the contract proposal.

Sawed and sealed joints in new asphalt pavement will be measured by the linear foot of joint complete in place and accepted by the Engineer. Sawing, bond breaker tape and joint sealant material will not be paid for as separate items but will be included in the unit price per linear foot for sawing and sealing transverse joints in asphalt pavement.

**S-413.05--Basis of Payment.** Joint sealer material will be paid for by the gallon when measured as prescribed above, which price shall be full compensation for all materials, equipment, tools, labor and incidentals necessary to complete the work.

Joints and cracks, cleaned, sealed and/or filled, will be paid for by the linear foot as prescribed in above, which price shall be full compensation for all materials, equipment, tools, labor and incidentals necessary to complete the work.

Sawing and sealing transverse joints in new asphalt pavement, accepted and measured as prescribed, will be paid for at the contract unit price per linear foot; which price shall be full compensation for locating and transferring the location of existing joints to establish new joint locations, for all required sawing, for furnishing all materials, including bond breaker tape and joint sealant materials, for all cleaning, pouring, trimming, cleanup and disposal of all excess and waste, for protective screening; for all pertinent operations necessary and incidental to the construction as indicated herein, and for all equipment, tools, labor, and incidentals necessary to complete the work.

Payment will be made under:

<b><u>S-413-A:</u></b> Joint Sealer Material	- per gallon
<b><u>S-413-B:</u></b> Cleaning and Sealing Joints	- per linear foot
<b><u>S-413-C:</u></b> Cleaning and Sealing Cracks	- per linear foot
<b><u>S-413-D:</u></b> Cleaning and Filling Joints	- per linear foot
<b><u>S-413-E:</u></b> Sawing and Sealing Transverse Joints in Asphalt Pavement	- per linear foot

**Sections S-414 thru S-499 - Blank.**





**Sections S-501 thru S-599 - Blank.**



<u>Section</u>	<u>Page</u>
S-600 - INCIDENTAL CONSTRUCTION	6-1
S-601 - STRUCTURAL CONCRETE	6-1
S-602 - REINFORCING STEEL	6-6
S-603 - CULVERTS AND STORM DRAINS	6-9
S-604 - MANHOLES, INLETS AND CATCH BASINS	6-23
S-605 - UNDERDRAINS	6-28
S-606 - GUARD RAIL	6-35
S-607 - Blank	6-39
S-608 - CONCRETE SIDEWALKS AND DRIVEWAYS	6-40
S-609 - CONCRETE GUTTER, CURB AND COMBINATION CURB AND GUTTER	6-43
S-610 - Blank	6-47
S-611 - BRICK MASONRY	6-48
S-612 - PRESSURE GROUTING	6-51
S-613 - ADJUSTMENT OF CASTINGS, GRATINGS AND UTILITY APPURTENANCES	6-58
S-614 - and S-615 - Blank.	6-59
S-616 - TRAFFIC ISLAND PAVEMENT	6-60
S-617 - RIGHT-OF-WAY MARKERS	6-64
S-618 - MAINTENANCE OF TRAFFIC AND TRAFFIC CONTROL PLAN	6-66
S-619 - HOT SPRAY PAINT TRAFFIC MARKINGS	6-72
S-620 - COLD PLASTIC PAVEMENT MARKINGS	6-77

S-621 - THERMOPLASTIC TRAFFIC MARKINGS	6-79
S-622 - thru S-626 - Blank	6-82
S-627 - RAISED PAVEMENT MARKERS	6-83
S-628 - and S-629 - Blank	6-85
S-630 - TRAFFIC SIGNS AND DELINEATORS	6-86
S-631 - FLOWABLE FILL	6-91
S-632 - ROADBED RECLAMATION	6-94
S-633 - thru S-699 - Blank	6-98

**SECTION S-601 - STRUCTURAL CONCRETE**

**S-601.01--Description.** This work shall consist of furnishing and placing portland cement concrete for specified structures in accordance with these specifications and in reasonably close conformity with the lines, grades, and dimensions shown on the plans or established by the Engineer.

Structural concrete will be divided into two groups. One group will be designated as Structural Concrete. The other group will be designated as Structural Concrete, Minor Structures. Unless otherwise specified in the contract Structural Concrete, Minor Structures, will include inlets, catch basins, junction boxes, headwalls, and pipe collars, regardless of the concrete quantity required for each of these structures; and other small structures containing less than 3.0 cubic yards of concrete each.

**S-601.02--Classification of Concrete.** Concrete for this work shall be the class specified on the plans or in the bid schedule of the contract. Classes of concrete are identified in S-804.02.6.

**MATERIALS**

**S-601.03--Materials.** Materials for structural concrete and their use, care, and handling shall be in accordance with S-804.02. In addition Type IP portland cement meeting the requirements of S-701.03 will be permitted. Sampling and testing will be in accordance with S-804.02.3. The composition of the concrete for the class specified will be in accordance with the Master Proportion Table for Structural Concrete as shown in S-804.02.10.

**S-601.03.1--Precast Units.** Design standards normally contemplate that structural concrete will be cast in place. However, the Contractor may request approval from the Engineer to furnish and install precast units in lieu of cast-in-place units. The request shall be accompanied by detailed drawings of the precast units and design data certified by a registered Professional Engineer as to structural and functional adequacy.

The foundation for precast units shall be carefully shaped to the precise contour and grade of the bottom of the unit before the unit is placed.

Precast units which are to be joined to other units shall be designed and manufactured with proper and adequate joints. Joints shall be sealed with a joint material meeting the applicable requirements of S-707.

No additional payment will be allowed for precast units approved for use. Pay items and quantities will be as in cast-in-place in accordance with design standards.

### CONSTRUCTION REQUIREMENTS

**S-601.04--Composition of Concrete.** The composition of the concrete shall be in accordance with S-804.02.

**S-601.05--Batching.** Measuring and batching of component materials shall be in accordance with the applicable provisions of S-804.

**S-601.06--Mixing and Conveying Concrete.** Concrete shall be mixed and conveyed in accordance with the applicable provisions of S-804.03.

**S-601.07--Cold or Hot Weather Concreting.** Requirements for placement, protection, and curing of concrete during cold or hot weather are stipulated in S-804.03.16.

**S-601.08--Consistency.** The slump of the concrete, determined in accordance with the provisions of S-700.03, shall conform to the applicable requirements of S-804.

**S-601.09--Falsework and Forms.**

**S-601.09.1--Falsework.** Falsework shall be in accordance with the applicable provisions of S-804.03.13.

**S-601.09.2--Forms.** Forms shall conform to the requirements of S-804.03.14.

**S-601.09.3--Removal of Falsework, Forms, and Housing.** The removal of falsework, forms, and the discontinuance of heating, shall be in accordance with the provisions and requirements of S-804.03.15, and in addition shall conform to the following age or cylinder strength requirements:

	<u>Column A</u>	<u>Column B</u>
Wingwall and Wall Forms not under Stress	24 to 48 hours*, minimum	1,000 psi
Wall Forms under Stress	7 days, minimum	2,200 psi
Backfill and Cover	3 days per foot clear span or clear height, whichever is the greater (10 days minimum)	2,400 psi

\* As directed by the Engineer.

If Type IP or Types I or II portland cement plus fly ash is used, only Column B will be applicable.

When the walls and top slab of box culverts and box bridges are not to be poured monolithically, extreme care shall be used when forming and pouring the top slab on walls in which the concrete has not attained its full design strength. In order to prevent damage to fresh concrete, either of the following methods of forming and pouring may be used:

1. Subject to approval by the Engineer, the wall forms and deck forms may be so constructed and separately supported and braced that the walls may be poured and the wall forms removed as for wall forms not under stress. The Engineer may require a detailed plan of the proposed method of forming for his approval. When this method of forming is used, the deck forms shall be in place and adequately and independently supported throughout before pouring the walls. Deck forms shall overlay the top edge and be flush with the face of the inside wall forms, but shall not be dependent upon any part of the inside wall forms for support. The intersection of the wall and deck forms shall be mortar tight. The wall forms may be constructed slightly less than the specified inside clear height of the structure and wedged upward from the bottom of the riser wall to permit easier removal. When this method is used, the concrete in the wall shall be poured flush with the top of the deck form.
2. At the option of the Contractor, the walls may be formed, adequately braced, and poured before the deck forms are in place. In this case the forms may be removed as for walls not under stress. Before erecting any part of the forming for the top slab, the concrete in the walls shall have attained the age or the strength specified for the removal of wall forms under stress.
3. The Contractor may elect to form and adequately support and brace the wall and deck forms as a composite unit before pouring the walls. In this case the outside forms may be removed as indicated for wall forms not under stress provided adequate provisions are made for forming the outer (vertical) surfaces for the subsequent deck pour. The inside wall forms shall remain in place as indicated for wall forms under stress.

**S-601.09.4--Damage to Previously Placed Concrete.** In the event previously placed concrete is damaged, all work on the affected structure shall cease immediately for an engineering assessment of the damage and the corrective work to be performed. No additional work shall be performed until this determination has been made, and the Engineer has given the Contractor approval to proceed with the corrective work and subsequent construction. All corrective work required shall be performed by the Contractor at no additional cost to the Project.

**S-601.10--Foundations and Footings.** Foundations for structures shall be prepared in accordance with the requirements and provisions of S-206.

All footings shall be poured "dry". Where footings can be placed in the "dry" without the use of cribs or cofferdams, the Engineer may permit back forms to be omitted, and concrete poured against the faces of the excavation.

**S-601.11--Placing Reinforcing Steel.** Reinforcing steel shall be placed in accordance with the requirements of S-602 and as shown on the plans.

**S-601.12--Handling and Placing Concrete.** Handling and placing concrete shall be in accordance with the provisions of S-804.03.6.

**S-601.13--Expansion and Fixed Joints.** All expansion and fixed joints shall conform to the applicable provisions of S-804.03.18.

**S-601.14--Finishing Concrete Surfaces.** Unless otherwise authorized, the surface of the concrete shall be finished immediately after form removal.

Surface finishes shall conform to the applicable provisions of S-804.03.19.

**S-601.15--Curing Concrete.** Concrete shall be cured in accordance with the provisions of S-804.03.17.

### **COMPENSATION**

**S-601.16--Method of Measurement.** Accepted quantities of structural concrete will be measured by the cubic yard. Except for changes ordered in writing by the Engineer, the neat dimensions shown on the plans will be used for computing volumes. The quantity of concrete in fillets, scorings, and chamfers one square inch or less in cross section area will be neglected in measurements.



No deductions will be made for the volume of concrete displaced by reinforcement, pipe or other conduits less than eight inches in nominal diameter, pipe posts, structural steel posts, or joint material.

When both Pay Item Numbers S-601-A and S-601-B are included in the contract, measurement of concrete for Pay Item No. S-601-B will be limited to inlets, catch basins, junction boxes, headwalls, and pipe collars, regardless of the concrete quantity required for each of these structures; and other small structures containing less than three cubic yards.

**S-601.17--Basis of Payment.** Structural concrete will be paid for at the contract unit price per cubic yard which shall be full compensation for completing the work specified.

Payment will be made under:

**S-601-A:** Class\_\_\_ Structural Concrete - per cubic yard

**S-601-B:** Class\_\_\_ Structural Concrete, Minor Structures - per cubic yard

**S-602.01--Description.** This work shall consist of furnishing and placing reinforcing steel in accordance with these specifications and in reasonably close conformity with the dimension, bending, spacing, and other requirements shown on the plans.

### **MATERIALS**

**S-602.02--Material Requirements.** Reinforcing steel shall conform with the requirements of S-711 and S-805.02.

### **CONSTRUCTION REQUIREMENTS**

**S-602.03--Bar List and Order Lists.** The bar lists and bending schedules shown on the plans are primarily for the purpose of estimating quantities. Lengths of box culverts and box bridges, and depths of inlets, etc. shown on the plans are also approximate. The Contractor shall verify the quantity, size, and shape of the reinforcement for compliance with the structural drawings and make the necessary corrections, if any, before ordering. In the case of box culverts, box bridges, inlets, etc.; verification shall be made after the Engineer has furnished the Contractor with a list of the staked lengths or depths for structures. Errors in the bar list and bending schedule shall not be cause for adjustment of the contract unit price, and the Contractor shall be fully responsible for all expenses caused by his failure to furnish the proper size, shape, length, and quantity of reinforcing steel required.

When stipulated in the contract, or at the option of the Contractor when not stipulated, order lists and bending diagrams shall be furnished by the Contractor to the Engineer for approval. In these cases no materials shall be ordered until the lists and bending diagrams have been approved. The approval of order lists and bending diagrams by the Engineer will in no way relieve the Contractor of the responsibility for the correctness of the lists and diagrams. All expense incidental to the revision of materials furnished in accordance with such lists and diagrams to make them comply with the design drawings and lengths as staked by the Engineer shall be borne by the Contractor.

**S-602.04--Protection of Materials.** Steel reinforcement shall be protected in accordance with S-805.03.1.

**S-602.05--Bending.** Bending shall be in accordance with S-805.05.

**S-602.06--Placing and Fastening.** The steel reinforcement shall be accurately placed in the positions shown on the plans and firmly held during the placing and setting of concrete. Bars shall be tied at all intersections, except where spacing is less than one foot in each direction then alternate intersections shall be tied.

All reinforcing steel shall be securely spaced from the forms and between adjacent reinforcement by means of approved precast mortar blocks (of minimum size for adequacy) or metal spacers or devices. Where possible, all spacer devices shall be arranged so that they cannot be detected in the completed structure. Metal devices which are in contact with the exterior surface of the concrete shall be one of the types specified in S-711.02.7. Gravel, pieces of broken stone or brick, metal pipe, and wooden blocks shall not be used for spacers or chairs.

Reinforcement shall be accurately and securely placed to the dimensions shown on the plans, with a tolerance of one-half inch, then inspected and approved by the Engineer prior to the placing of concrete. Concrete placed in violation of this provision may be rejected and its removal required.

Substitution of different size bars will be permitted only with specific authorization by the Engineer. If steel is substituted, it shall have a cross sectional area equivalent to or greater than the design area.

**S-602.06.1--Splicing.** Except where shown on the plans, splicing of bars will not be permitted without the written approval of the Engineer. Splices, when permitted, shall be staggered as far apart as possible.

Unless otherwise shown on the plans spliced bars shall be lapped twenty (20) diameters. In lapped splices, the bars shall be placed in contact and wired together in a manner that will maintain the minimum clear distance specified between bars and to the surface of the concrete.

Welding of reinforcing steel will be permitted only if detailed on the plans or if authorized by the Engineer in writing. If done, it shall conform to AWS Recommended Practices for Welding Reinforcing Steel, Metal Inserts, and Connections in Reinforced Concrete Construction.

**S-602.06.2--Lapping of Mesh and Bar Mats.** Sheets of mesh or bar mat reinforcement shall overlap each other sufficiently to maintain a uniform strength and shall be securely fastened at the ends and edges. The edge lap shall be at least one mesh in width.

**COMPENSATION**

**S-602.07--Method of Measurement.** Complete and accepted steel reinforcement will be measured in pounds based on the computed weight of the reinforcement shown on the plans or authorized. In cases where a structure is measured and paid for by the unit, complete in place, no measurement of reinforcing steel will be made.

The weight of plain or deformed bars and bar mats will be computed from the weights shown in the table of areas and weights in S-711.02.1.

The weight for payment of steel fabric reinforcement will be computed from the theoretical weight of plain wire. If the weight per unit of area of the fabric is shown on the plans, that weight will be used for measurement.

The weight for payment of structural steel reinforcement will be the theoretical weight of the material used.

No allowance will be made for clips, wire, separators, wire chairs, and other material used in fastening the reinforcing in place. If bars are substituted upon the Contractor's request and as a result more steel is used than specified, only the quantity specified will be measured.

When splice laps, other than those shown on the plans, are made for the convenience of the Contractor, the extra steel will not be included in the measurement.

**S-602.08--Basis of Payment.** Reinforcing steel will be paid for at the contract unit price per pound which shall be full compensation for completing the work specified.

Payment will be made under:

**S-602-A:** Reinforcing Steel - per pound

**S-603.01--Description.** This work shall consist of the construction or reconstruction of pipe culverts, precast box culverts, cattlepasses, storm drains, sewers, downspouts, special sections and headwalls, hereinafter referred to as "conduit," in accordance with these specifications and in reasonably close conformity with the lines and grades shown on the plans or established. It shall also consist of furnishing all materials, except those specified to be furnished by the County, and joining the work to other conduit, catch basins, manholes, inlets, etc., as may be required to complete the work as designated.

This work shall also consist of constructing conduits for the encasement of underground utilities or for other use by the method of jacking or boring in accordance with these specifications and in reasonably close conformity with the lines and grades specified on the plans or established.

**MATERIALS**

**S-603.02--Material Requirements.** Conduit shall conform to the design and dimensions shown on the plans, and materials shall meet the requirements specified in the following sections or subsections:

Bituminous coated corrugated aluminum pipe and pipe arches . . . . .	S-709.11
Bituminous coated corrugated metal pipe and pipe arches . . . . .	S-709.03
Bituminous coated paved invert corrugated aluminum pipe and pipe arches . . . . .	S-709.12
Bituminous coated paved invert corrugated metal pipe and pipe arches . . . . .	S-709.04
Bituminous plastic sealer for joints . . . . .	S-707.05
Cast iron pipe . . . . .	S-709.01
Concrete arch pipe end sections . . . . .	S-708.04
Concrete for headwalls . . . . .	S-601
Concrete pipe cattlepasses . . . . .	S-708.03
Corrugated aluminum pipe and pipe arches . . . . .	S-709.09
Corrugated metal pipe and pipe arches . . . . .	S-709.02
Corrugated poly vinyl chloride (PVC) pipe . . . . .	S-708.17
Corrugated polyethylene pipe . . . . .	S-708.17
Elbows and branch connections for concrete pipe . . . . .	S-708.23
Flexible plastic gaskets for joints . . . . .	S-707.06
Joint Mortar . . . . .	S-707.02
Joints for sanitary sewers . . . . .	S-603.06, S-707.04, S-707.06
Metal end sections, elbows, and branch connections . . . . .	S-709.18
Non-reinforced concrete pipe . . . . .	S-708.02
Polymer coated corrugated metal pipe and pipe arches . . . . .	S-709.05
Precast box culverts . . . . .	S-708.22
Reinforced concrete arch pipe . . . . .	S-708.14
Reinforced concrete elliptical pipe . . . . .	S-708.15

Reinforced concrete end sections . . . . .	S-708.04
Reinforced concrete pipe . . . . .	S-708.02
Reinforcing steel . . . . .	S-602
Rubber-type gaskets . . . . .	S-707.04
Steel pipe . . . . .	S-709.19

When material requirements provide for modifications of design, acceptable modified designs will be shown on the plans.

**CONSTRUCTION REQUIREMENTS**

**S-603.03--Excavation.** Except for conduit to be installed by jacking and boring, trenches shall be excavated in accordance with the requirements of S-206 to a width sufficient to allow for proper jointing of the conduit and thorough compaction of the bedding and backfill material under and around the conduit. Where feasible, trench walls shall be vertical.

The completed trench bottom shall be firm for its full length and width. Where required, in the case of cross drains, the trench shall have the camber specified.

Where conduit is to be placed in embankment, the excavation shall be made after the embankment has been completed to the specified height above the flow line of the conduit. In all cases the height above flow line shall be at least one foot.

In the case of pipe to be jacked or bored, only the trench excavation and bedding as set out in S-603.11 shall be performed.

**S-603.04--Bedding.** Except for conduit placed in a vertical position or jacked or bored, the conduit bedding shall conform to one of the classes specified. When no bedding class is specified the requirements for Class C bedding or Class C modified bedding, as applicable shall apply.

CLASS A bedding shall consist of a continuous concrete cradle conforming to the plan details, and constructed on an approved foundation.

CLASS B bedding shall consist of bedding the conduit to a depth of at least thirty (30) percent of the vertical outside dimension of the conduit. The thickness of bedding material beneath the pipe shall be at least four inches. The bedding material shall be sand or selected sandy soil, all of which passes a 3/8" sieve and not more than ten (10) percent of which passes a No. 200 sieve. The layer of bedding material shall be shaped to fit the conduit for at least fifteen (15) percent of its total height. Recesses in the trench bottom shall be shaped to accommodate the bell when bell and spigot type conduit is used.

CLASS C bedding shall consist of bedding the conduit to a depth of at least ten (10) percent of its total height. The bed shall be shaped to fit the conduit and shall have recesses shaped to receive the bell if bell and spigot type pipe is used.

CLASS C MODIFIED bedding shall consist of bedding corrugated conduit to a depth of at least ten (10) percent of its total height. A bedding blanket of approved silty loam, sandy loam, concrete sand, or other approved sand or sandy soil shall be roughly shaped to fit the bottom of the pipe. Minimum thickness before placing pipe shall be as follows:

- 1 inch for 1/2 inch deep corrugations
- 2 inches for 1 inch deep corrugations
- 3 inches for 2 inches or 2 1/2 inches corrugations

For structural plate pipe the length of bedding arc need not exceed the width of the bottom plate.

Bedding for precast concrete box culverts shall consist of at least two inches of granular material (Class 9, Group C or better) placed between graded forms set at least one foot outside each outside wall of the box culvert. The granular material shall be shaped to fit the bottom of the precast box culvert sections by screeding off the graded forms. After placement of the precast box culvert sections on the graded bedding, the forms may be removed and reused.

**S-603.05--Laying Conduit.** The conduit laying shall begin at the staked location of the downstream end of the conduit line. The lower segment of the conduit shall be in contact with the shaped bedding throughout its full length. Bell or groove ends of rigid conduits and outside circumferential laps of flexible conduits shall be placed facing upstream. Flexible conduits shall be placed with longitudinal laps or seams at the sides.

Paved or partially lined conduit shall be laid so that the longitudinal center line of the paved segment coincides with the flow line. Elliptical and elliptically reinforced conduits shall be placed with the major axis within five degrees of a horizontal plane through the longitudinal axis of the conduit.

Construction requirements for end sections shall conform to the requirements for placing the pipe to which they are joined.

At the Contractor's option, subject to the written approval of the Engineer, concrete headwalls conforming to the MDOT Standard Drawings may be substituted in lieu of premanufactured end sections without change in compensation.

**S-603.06--Joining Conduit.**

**S-603.06.1--Storm Drainage.** Rigid conduits may be either bell and spigot or tongue and groove design unless one type is specified. The method of joining conduit sections shall be such that the ends are fully entered, and the inner surfaces are reasonably flush and even. Unless otherwise specified, joints shall be sealed with preformed rubber-type gaskets, bituminous plastic sealer, or flexible plastic gaskets. When a specific type of joint sealer is required, it shall be indicated on the plans.

Joints for precast concrete box culverts shall be made with bituminous plastic sealer.

Rubber-type gaskets shall be installed so as to form a flexible watertight seal.

For joints to be sealed with bituminous plastic, the joining ends shall be wiped clean and dry. The plastic compound shall be applied cold to the entire surface of tongues and grooves, the entire surface of bells and spigots, and the entire area of metal pipes to be covered by connecting bands. Sections of concrete pipe shall be forced together, and sections of metal pipe banded together, with excess compound extruding both inside and outside the pipe. Excess compound shall be removed from interior surfaces, and the exterior shall be finished reasonably flush. After pipe has been joined with bituminous plastic compound, suitable kraft or other approved paper shall be placed over the outside joints to avoid mixing of soil with the compound.



For joints to be sealed with preformed plastic gasket material, the pipe shall be installed in a dry trench. Joints shall be made in such a manner that a slight internal extrusion of the plastic gasket will occur for the full circumference when the sections of pipe are forced together. Installation shall be in accordance with these specifications and the manufacturer's instructions. Plastic gasket material shall be applied only to surfaces which are dry. A primer of the type recommended by the manufacturer of the plastic gasket shall be applied to the tongue and groove and to the end surfaces, and the surface to be primed shall be clean and dry when the primer is applied.

During cold weather the joint surfaces and the gasket shall be lightly heated, without damage to the pipe or joint material, immediately prior to forcing the sections of pipe together. During hot weather the Contractor shall place kraft or other approved paper over the joints to avoid mixing soil with the plastic gasket material.

For joints constructed of either bituminous plastic sealer or preformed plastic material, special care shall be taken to provide an equal uniform joint between pipe sections and to prevent one section from supporting the other. Backfilling operations may follow immediately.

Flexible conduits shall be firmly joined by coupling bands. The ends of flexible conduits fabricated with helical corrugations shall be adapted by reforming and/or modification for circumferential corrugated coupling bands. The width and thickness of corrugated bands for both circumferential and helical corrugated flexible conduits shall be in accordance with AASHTO Designation: M 36 except that the bands shall be no less than 10½ inches in width.

In lieu of the preceding requirements and in addition to being supplied or recommended by the pipe manufacturer, coupling bands for joining corrugated polyethylene pipe shall be in accordance with AASHTO Designation: M 294 and shall meet or exceed the soil-tightness requirements of the AASHTO Standard Specifications for Highway Bridges, Section 26, paragraph 26.4.2.4 (e).

Corrugated polyethylene pipe may also be furnished with bell & spigot type joints with O-ring rubber gasket meeting ASTM Designation: F 477 placed on the spigot end. At least two (2) corrugations of the spigot end must insert into the bell end.

Joints and fittings for poly (vinyl chloride) (PVC) pipe shall meet the requirements of ASTM Designation: F 949.

**S-603.06.2--Pipes With Gaskets.** Unless otherwise specified, joints for pipe requiring gaskets shall conform to the following:

- (a) Pipes requiring gaskets shall be constructed to accommodate the gasket in accordance with the recommendations of the manufacturer of the gasket. Rubber gaskets shall comply with S-707.04, and flexible plastic gaskets shall comply with S-707.06.
- (b) In municipalities and other local governments having codes and specifications for joining sanitary sewer conduit, the local codes and specifications shall be applicable.
- (c) Depending upon the type of pipe specified and the joint to be used, the Contractor shall perform the joining in accordance with the recommendations of the manufacturer of the joint material to the extent that the line will be water proofed both from infiltration and exfiltration insofar as is practicable. Evidence of leakage shall be corrected immediately.
- (d) Evidence of leakage or suspected leakage may be cause for requiring the Contractor to perform testing to determine the leakage present. In the case of sanitary sewer lines, leakage exceeding the tolerance permitted under the local governing code, or in the absence of such code the tolerances permitted by the Mississippi Department of Environmental Quality, Office of Pollution Control, will not be allowed. Leakage in excess of the tolerances permitted shall be corrected by reworking the line as necessary. Retesting may be required if deemed by the Engineer to be indicated. All testing shall be at no additional cost to the Project.

**S-603.07--Relaid Pipe.** These construction specifications shall equally apply to relaid conduits. In addition, conduit salvaged for relaying shall be cleaned of all foreign material prior to reinstallation. All pipe damaged through carelessness or negligence on the part of the Contractor shall be replaced by new pipe or approved pipe at no additional cost to the project.

Pipe and end sections designated for removal and relaying shall be removed in accordance with the provisions of S-202.04.

**S-603.08--Field Strutting.** Where required by the plans, the vertical diameter of round flexible pipe shall be uniformly increased five percent by means of jacks applied after the entire line of pipe has been installed on the bedding but before backfilling. The vertical elongation shall be uniformly maintained by means of sufficient sills and struts or by sufficient horizontal ties as specified. Only horizontal ties shall be used for paved invert pipe.

Unless otherwise directed, ties and struts shall be left in place until the embankment is completed and compacted.

**S-603.09--Backfilling.** Conduit shall be inspected before backfill is placed. Conduit found to be out of alignment, unduly settled, or damaged shall be taken up and relaid or replaced. After approval of conduit, it shall be backfilled with specified material in accordance with S-203.09.3.3.

**S-603.10--Imperfect Trench.** Under this method the embankment shall be completed to a height above the conduit equal to the vertical outside diameter of the conduit plus one foot. A trench equal in width to the outside horizontal diameter of the conduit shall then be excavated to within one foot of the top of the conduit with the trench walls being as nearly vertical as possible. This trench shall be loosely filled with highly compactible soil. Straw, hay, corn stalks, leaves, brush, or sawdust may be used to fill the lower one-fourth to one-third of the trench. Construction of the remainder of the embankment shall then proceed in a normal manner.

**S-603.11--Pipes and Encasements Jacked or Bored.** No pipe shall be placed by jacking or boring unless so designated in the contract.

When jacking or boring is designated, the area of placement shall be carefully investigated so as not to interfere with existing underground utilities. Care shall also be taken to keep the disturbed area of construction to a minimum.

The Engineer will establish line and grade and the limits, if any, of placement to be made by conventional (open trench) methods for each line of pipe. Unless otherwise shown on the plans, sections of steel pipe shall be joined by welding for the full circumference of the pipe to form a continuous, rigid, watertight structure of the required length. Welding shall be performed in accordance with S-810.03.5.

**S-603.11.1--Jacking.** The designated strength of the pipe to be jacked is determined for the final loading under the embankment. Additional reinforcement or strength of pipe required to withstand jacking pressure shall be the responsibility of the Contractor. Extra strength pipe furnished by the Contractor shall be at no additional cost to the project.

Pipe larger than 3 1/2 inches ID shall not be pushed or jacked without boring or otherwise removing the soil as the pipe is advanced.

When required, suitable pits or trenches shall be excavated for the jacking operation and for placing the end joints of pipe. Where necessary, they shall be securely sheeted and braced to prevent caving.

Where pipe is required to be installed under railroads, highways, streets or other facilities by jacking or boring methods, construction shall be done in a manner that will not interfere with the operation of the facility or weaken the roadbed or structure.

Jacks for forcing the pipe through the roadbed shall have a jacking head constructed in such a manner as to apply uniform pressure around the ring of the pipe. The pipe to be jacked shall be set on guides braced together to properly support the section of the pipe and direct it to the proper line and grade. In general, roadbed material shall be excavated just ahead of the pipe, the excavated material removed through the pipe, and the pipe then forced through the roadbed into the excavated space.

When requested, the Contractor shall furnish for the Engineer's approval, a plan showing his proposed method of handling. The plan shall include the design for the jacking head, and show the jacking support or back stop, arrangement and position of jacks, pipe guides, etc., complete in assembled position. The approval of this plan by the Engineer will not relieve the Contractor from his responsibility to obtain the specified results.

The diameter of the excavation shall conform to the outside circumference of the pipe as closely as practicable. Voids which develop during the installation operation and which are determined by the Engineer to be detrimental to the work shall be pressure grouted with an approved mix.

The distance that the excavation extends beyond the end of the pipe will depend upon the character of the excavated material, but shall not exceed two feet in any case. This distance shall be decreased on instructions from the Engineer if the character of the material being excavated makes it desirable.

The pipe shall be jacked from the low or downstream end. Variation in the final position of the pipe from the line and grade established by the Engineer will be permitted only to the extent of two percent in lateral alignment and one percent in vertical grade, provided that the final grade of flow line is in the direction designated.

If the Contractor desires, he may use a cutting edge around the head end which extends a short distance beyond the pipe end and has inside angles or lugs to keep the cutting edge from slipping back into the pipe.

Once jacking of pipe has begun, the operation shall be carried on without interruption, insofar as practicable, to prevent the pipe from becoming firmly set in the embankment.

All pipe damaged in jacking operations shall be removed and replaced by the Contractor at their expense.

Pits or trenches excavated to facilitate jacking operations shall be backfilled immediately after the jacking has been completed.

**S-603.11.2--Boring.** The boring shall proceed from a pit provided for the boring equipment and workmen. Excavation for pits and installation of shoring shall be as outlined under jacking. The location of the pit shall meet the approval of the Engineer. The holes are to be bored mechanically. The boring shall be done using a pilot hole. By this method an approximate two inch pilot hole shall be bored the entire length of the crossing and shall be checked for line and grade on the opposite end of the bore from the work pit. This pilot hole, when approved, shall serve as the centerline of the larger diameter hole to be bored. Excavated material shall be placed near the top of the working pit and disposed of as required. The use of water or other fluids in connection with the boring operation will be permitted only to the extent to lubricate cuttings as provided herein. Jetting will not be permitted.

In unconsolidated soil formations, a gel-forming colloidal drilling fluid consisting of at least ten (10) percent of high grade carefully processed bentonite may be used to consolidate cuttings of the bit, seal the walls of the hole, and furnish lubrication for subsequent removal of cuttings and installation of the pipe immediately thereafter.

Allowable variation from line and grade shall be as specified under jacking. Precise measures are to be taken to prevent overcutting. Overcutting in excess of one-half inch shall be remedied by pressure grouting.

**S-603.11.3--Grouting, Backfilling, and Cleanup.** After the jacked conduit is in place, all joints in concrete pipe shall be cleaned carefully and pointed from the inside to afford a smooth continuous interior surface.

Extension of the line beyond that required to be jacked or bored shall be by conventional methods as set out in this section.

As soon after jacking as possible, the interstices around the outside of the pipe shall be filled by pressure grouting. The grout mixture shall consist of fine sand or silt, Type I cement of not less than fifteen (15) percent of volume, and water. The grout shall be placed through holes bored at such intervals that the grout can be determined as rising in an adjacent hole at least six inches above the top of the pipe. The water content of the grout shall be the minimum necessary to provide proper placement. Grouting shall be performed by qualified personnel with equipment especially designed for the purpose.

At the end of each day's grouting operation, or at the completion of the grouting operation for each line of pipe, whichever occurs first, the conduit shall be carefully inspected on the inside and all grout which has penetrated the pipe shall be removed and the inside surface wiped clean. Other waste grout which will impair the work shall be removed and disposed of at on-project sites as designated by the Engineer.

After successive operations are completed, all sheeting, shoring, etc., shall be removed, excavations backfilled to the surface of the existing ground or as directed, the backfill compacted in accordance with the specifications, and all surplus material disposed of at on-project sites as designated by the Engineer.

### COMPENSATION

**S-603.12--Method of Measurement.** The lengths of pipe and precast box culverts, complete in place, will be measured by the linear foot by multiplying the number of commercial lengths by the nominal length per section; except, portions of commercial lengths extending more than four feet beyond the staked ends of the conduit will not be measured for payment.

Unless otherwise indicated on the plans, sections of lines of conduits placed by conventional methods will not be measured as pipe jacked or bored.

End sections, headwalls, elbows, branch connections, and other appurtenances for which pay items are listed will be measured by the number of units of the kind and size specified.

Pipe removed and relaid will be measured by the linear foot. End sections removed and relaid will be measured per each.

Excavation for conventionally installed conduits will be measured and paid for as set out in S-206. Excavation for conduits placed by jacking or boring will not be measured for separate payment.

Excavation for precast box culverts will be measured in cubic yards as set out in S-206 for cast-in-place box culverts of comparable sizes.

**S-603.13--Basis of Payment.** Accepted quantities of pipe and precast box culverts will be paid for at the contract unit price per linear foot.

End sections, headwalls, elbows, branch connections, and other appurtenances for which pay items are listed in the contract will be paid for at the contract unit price per each.

Pipe removed and relaid will be paid for at the contract unit price per linear foot. End sections removed and relaid will be paid for at the contract unit price per each.

The prices thus paid shall be full compensation for completing the work specified. Materials or work for which a pay item is not included and are necessary to complete the work under this section shall be furnished or performed and shall be considered incidental to the completed construction.

**FERROUS METAL CONDUIT**

Payment will be made under:

**S-603-A:** \_\_\_ “ Steel Pipe, Wall Thickness \_\_\_ - per linear foot

**S-603-B:** \_\_\_ “ Cast Iron Pipe, Class \_\_\_, \_\_\_\_\_ - per linear foot  
(Description)

**CONCRETE CONDUIT**

**S-603-C-A:** \_\_\_ “ Reinforced Concrete Pipe, Class \_\_\_ - per linear foot

**S-603-C-B:** \_\_\_ “ Reinforced Concrete Pipe, End Section - per each

**S-603-C-C:** \_\_\_ “ Non-Reinforced Concrete Pipe, Class \_\_\_ - per linear foot

**S-603-C-D:** \_\_\_ “ x \_\_\_ “ Reinforced Concrete Arch Pipe, Class \_\_\_ - per linear foot

**S-603-C-E:** \_\_\_ “ x \_\_\_ “ Reinforced Concrete Arch Pipe, End Section - per each

**S-603-C-F:** 48 “ x 72 “ Reinforced Concrete Pipe Cattlepass - per linear foot

For conduit required to be jacked or bored, the appropriate pay item listed above will contain the term (Jacked or Bored), (Jacked) or (Bored), as applicable.

**CORRUGATED FERROUS METAL CONDUIT**

**S-603-M-A:** \_\_\_ “ \_\_\_ \* Coated Corrugated Metal Pipe,  
\_\_\_\_\_ Gage, \_\_\_ Corrugation - per linear foot

**S-603-M-B:** \_\_\_ “ \_\_\_ \* Coated Corrugated Metal End Section,  
\_\_\_\_\_ Gage - per each

**S-603-M-C:** \_\_\_ “ x \_\_\_ “ \_\_\_ \* Coated Corrugated Metal Arch Pipe,  
\_\_\_\_\_ Gage, \_\_\_ Corrugation - per linear foot

**S-603-M-D:** \_\_\_\_ “ x \_\_\_\_ “ \* Coated Corrugated Metal,  
End Section, \_\_\_\_ Gage - per each

**S-603-M-E:** \_\_\_\_ “ \* Coated Paved Invert Corrugated ,  
Metal Pipe, \_\_\_\_ Gage, \_\_ Corrugation - per linear foot

**S-603-M-F:** \_\_\_\_ “ \* Coated Paved Invert Corrugated Metal  
End Section, \_\_\_\_ Gage - per each

**S-603-M-G:** \_\_\_\_ “ x \_\_\_\_ “ \* Coated Paved Invert Corrugated  
Metal Arch Pipe, \_\_\_\_ Gage, \_\_ Corrugation - per linear foot

**S-603-M-H:** \_\_\_\_ “ x \_\_\_\_ “ \* Coated Paved Invert Corrugated  
Metal End Section, \_\_ Gage - per each

\* Type Coating to be shown as either Zinc, Aluminum, Polymeric or Bituminous.

NOTE: The wall thickness of pipe specified for various coating types will vary according to design policy.

### **CORRUGATED NON-FERROUS METAL CONDUIT**

**S-603-N-A:** \_\_\_\_ “ Corrugated Aluminum Pipe,  
\_\_\_\_ Gage, \_\_ Corrugation - per linear foot

**S-603-N-B:** \_\_\_\_ “ Corrugated Aluminum End Section,  
\_\_\_\_ Gage - per each

**S-603-N-C:** \_\_\_\_ “ x \_\_\_\_ “ Corrugated Aluminum  
Arch Pipe, \_\_\_\_ Gage, \_\_ Corrugation - per linear foot

**S-603-N-D:** \_\_\_\_ “ x \_\_\_\_ “ Corrugated Aluminum  
End Section, \_\_\_\_ Gage - per each

**S-603-N-E:** \_\_\_\_ “ Bituminous Coated Corrugated  
Aluminum Pipe, \_\_\_\_ Gage - per linear foot

**S-603-N-F:** \_\_\_\_ “ Bituminous Coated Corrugated Aluminum  
End Section, \_\_\_\_ Gage - per each

**S-603-N-G:** \_\_\_\_ “ x \_\_\_\_ “ Bituminous Coated Corrugated Aluminum  
Arch Pipe, \_\_ Gage, \_\_ Corrugation - per linear foot



**S-603-N-H:** \_\_\_\_ “ x \_\_\_\_ “ Bituminous Coated Corrugated Aluminum  
End Section, \_\_\_\_ Gage - per each

**S-603-N-I:** \_\_\_\_ “ Bituminous Coated Paved Invert, Corrugated  
Aluminum Pipe, \_\_\_\_ Gage, \_\_\_\_ Corrugation - per linear foot

**S-603-N-J:** \_\_\_\_ “ Bituminous Coated Paved Invert, Corrugated  
Aluminum End Section, \_\_\_\_ Gage - per each

**S-603-N-K:** \_\_\_\_ “ x \_\_\_\_ “ Bituminous Coated Paved Invert, Corrugated  
Aluminum Arch Pipe, \_\_\_\_ Gage, \_\_\_\_ Corrugation- per linear foot

**S-603-N-L:** \_\_\_\_ “ x \_\_\_\_ “ Bituminous Coated Paved Invert, Corrugated  
Aluminum End Section, \_\_\_\_ Gage - per each

### **CORRUGATED POLYETHYLENE CONDUIT**

**S-603-PE:** \_\_\_\_\_ " Corrugated Polyethylene Pipe - per linear foot

**S-603-PF:** \_\_\_\_\_ " Corrugated Polyethylene Pipe, End Section - per each

### **CORRUGATED POLY VINYL CHLORIDE CONDUIT**

**S-603-PVC:** \_\_\_\_\_ " Corrugated Poly Vinyl Chloride Pipe - per linear foot

### **PRECAST BOX CULVERTS**

**S-603-P-A:** \_\_\_\_ ' x \_\_\_\_ ' Precast Concrete Box Culvert - per linear foot

**S-603-P-B:** \_\_\_\_ ' x \_\_\_\_ ' Precast Concrete Box Culvert End Section - per each

**RELAI D PIPE**

**S-603-R-A:** \_\_\_\_ “ Pipe Relaid (\_\_\_\_\_) - per linear foot  
(Type & Class or Gage)

**S-603-R-B:** \_\_\_\_ “ Pipe Removed and Relaid (\_\_\_\_\_) - per linear foot  
(Type & Class or Gage)

**S-603-R-C:** \_\_\_\_ “ End Section Removed and Relaid (\_\_\_\_\_) - per each  
(Type & Class or Gage)

**SPECIALS AND CONCRETE HEADWALLS**

**S-603-S-A:** \_\_\_\_ “ \_\_\_\_ Elbow, (Materials per Pay Item No. \_\_\_\_ ) - per each  
(Size) (Angle)

**S-603-S-B:** \_\_\_\_ “ Branch Connection \_\_\_\_\_ - per each  
(Size) (Type & Description)

**S-603-S-C:** \_\_\_\_ “ \_\_\_\_ Headwall, Per Plan No. \_\_\_\_\_ - per each  
(Size) (Type)

**S-604.01--Description.** This work shall consist of the construction of manholes, inlets, and catch basins in accordance with these specifications and in reasonably close conformity with the details, lines, grades, and dimensions shown on the plans or established by the Engineer.

Precast sectional manholes shall consist of furnishing and assembling precast sections for manholes, together with necessary fittings, bases, and connections, all constructed in accordance with these specifications and in reasonably close conformity with the details, lines, grades and dimensions shown on the plans, or established.

**MATERIALS**

**S-604.02--Material Requirements.** The materials used in this construction shall meet the requirements of the following:

Masonry Brick (Grade SM)	S-706.01
Mortar	S-714.11
Concrete	S-601
Reinforcing Steel	S-711.01 and S-711.02
Gray Iron Castings	S-716.04

Bar gratings, unless otherwise specified, shall be constructed of plain, round, billet steel bars conforming with the requirements of AASHTO Designation M 31, Grade 60 or better.

All bars, anchors, frames, hangers, etc. for castings and plates shall be approved prior to installation.

Inlet and outlet pipes shall be of the type, class and size indicated on the plans and shall conform to the requirements as set out in S-603 for the particular type, class, and size of pipe specified.

Precast units will be considered for use under the provisions of S-601.03.01 and of S-601.04. Precast (sectional) manholes shall conform to the requirements of AASHTO Designation: M 199.

**CONSTRUCTION REQUIREMENTS****S-604.03--Construction Details.**

**S-604.03.1--Brick Masonry.** Brick masonry shall be constructed in conformity with the details shown on the plans and in accordance with the provisions of S-611.

Where irons or other fittings enter the brick work, they shall be placed as the work is laid up, thoroughly bonded, accurately spaced, and lined. Upon completion of the masonry and setting of castings and fittings, the inside and outside surfaces of the masonry shall be neatly plastered with mortar 1/2 inch thick. Plastering shall have a uniform, smooth finish and shall be neatly pointed to all fittings.

**S-604.03.2--Concrete Masonry.** Unless otherwise specified, concrete masonry shall be constructed of Class "B" concrete in accordance with the requirements of S-601.

**S-604.03.3--Reinforcement.** Reinforcement shall be placed as indicated on the plans or as directed and in accordance with the provisions of S-602.

**S-604.03.4--Optional Construction.** When plan standards indicate portions of the structure may be constructed of either brick masonry or concrete, the Contractor may use either concrete or brick masonry for these portions, provided the plan dimensions for wall thickness, etc. are maintained. In either case the masonry, whether concrete or brick, will be measured for payment as stipulated in S-604.04.

**S-604.03.5--Inlet and Outlet Pipes.** Unless otherwise directed, inlet and outlet pipes shall extend through the walls of manholes and catch basins for a sufficient distance beyond the outside surface to allow for connections and shall be cut flush with the wall on the inside surface and neatly pointed.

The concrete, or brick and mortar, shall be constructed around the pipes so as to prevent leakage and to form a neat connection.

**S-604.03.6--Castings, Gratings, and Fittings.** All castings and gratings shall be carefully handled. Injurious cracks, chips, surface mars, etc. which render them unsuitable for use or unsightly after being placed will be cause for rejection, and if so directed they shall be replaced.

The castings, gratings, and fittings shall be placed as indicated on the plans or as directed to line and grade and in such a manner that subsequent adjustments will not be necessary.

When castings or gratings are to be set in concrete or cement mortar, all anchors or bolts shall be in the correct place and position before the concrete or mortar is placed, and they shall not be disturbed while the concrete or mortar is hardening.

Castings and gratings placed on previously constructed masonry shall be set in mortar beds or anchored to the masonry as shown on the plans or as directed. The bearing surface of the original masonry shall present an even surface and conform to line and grade so that the entire face of the back of the casting will come in contact with the masonry.

Castings and gratings shall be set firm and snug so that they will not rattle, shake, or move unnecessarily.

**S-604.03.7--Precast Manholes.** As trenches are opened for the pipe conduit, truly leveled bases shall be prepared at each manhole site. The bases may be cast-in-place or may consist of precast base units. In either case, the seated base shall be truly horizontal. Inverts shall be smooth and accurately shaped to a semi-circular bottom conforming to the inside of the adjacent conduit, and extend upward at least half of the diameter of the conduit, or as shown on the plans. Joints shall be sealed in accordance with S-603.

Steps in the manhole may be of cast-iron, aluminum, wrought iron, plastic or other material approved by the Engineer. All steps shall be built into the walls of precast sections in straight alignment to form a continuous ladder with a maximum distance of 16 inches between steps.

Each precast section shall have not more than two holes for handling. The holes shall be plugged with mortar after installation.

Concrete covers may be precast, or cast at the site. The covers shall be cast accurately to the dimensions and design indicated on the plans.

**S-604.03.8--Excavation and Backfill.** Excavation shall be performed as required for proper construction. Backfill shall be performed in accordance with the provisions of S-203.09.3.3.

**S-604.03.9--Cleaning Up.** Upon completion, all structures shall be thoroughly cleaned of accumulations of silt, debris, and foreign matter. All surplus material shall be removed, and the site and the structure shall be maintained in a clean and neat condition until final acceptance.

### COMPENSATION

**S-604.04--Method of Measurement.** When either concrete masonry or brick masonry is permitted, and when concrete is specified, measurement will be by the cubic yard in accordance with S-601.16 for Structural Concrete - Minor Structures.

Precast manholes will be measured per linear foot of depth from the flowline of the manhole to the top of the cover, or as indicated on the plans.

Reinforcing steel will be measured per pound in accordance with S-602.07.

When brick masonry only is specified, measurement will be by the cubic yard or per thousand (M) brick in accordance with S-611.06.

Excavation will not be measured for payment as a separate item. The cost of excavation shall be included in the unit price bid for concrete or brick masonry.

Castings, gratings and metallic manhole covers will be computed in pounds from the dimensions shown on the plans and based on the unit weights of metals set out in S-810.04.4.

Fittings will not be measured for separate payment. Their cost shall be included in the price bid for concrete or brick masonry.

**S-604.05--Basis of Payment.** Structural concrete, reinforcing steel, and brick masonry will be paid for at the respective contract unit price in accordance with S-601.17, S-602.08, or S-611.07 as applicable.

Precast Manholes will be paid for at the contract bid price per linear foot of depth, which price shall be full compensation for all necessary excavation, sheeting, cribbing, shoring, bracing, well-pointing, furnishing and assembling all elements of the manhole including concrete bases & covers except metallic cover and frame, for all other items of work necessary and incident to the complete construction and for all equipment, labor, tools and incidentals necessary to complete the work.

Castings and gratings will be paid for at the contract unit price per pound for castings or gratings, complete in place. These prices shall be full compensation for completing the work specified.

Payment will be made under:

**S-604-A:** Castings - per pound

**S-604-B:** Gratings - per pound

**S-604-C:** Precast Manhole, \_\_\_\_\_" Diameter - per linear foot

**S-605.01--Description.** This work shall consist of furnishing all materials and constructing pipe underdrains in accordance with these specifications and in reasonably close conformity with the lines and grades indicated on the plans or established by the Engineer. It shall also include furnishing materials and constructing filter beds as specified.

### **MATERIALS**

**S-605.02--Material Requirements.**

**S-605.02.1--Drain Tile and Pipe.** Drain tile and pipe shall be of the classes and sizes indicated and shall meet the requirements of the following subsections:

Bituminous Coated Corrugated Aluminum Alloy Pipe for Underdrains . . .	S-709.13
Bituminous Coated Corrugated Metal Pipe for Underdrains . . . . .	S-709.07
Concrete Drain Tile . . . . .	S-708.06
Corrugated Aluminum Pipe for Underdrains . . . . .	S-709.10
Corrugated Metal Pipe for Underdrains . . . . .	S-709.06
Corrugated Polyethylene Drainage Tubing . . . . .	S-708.19
Geotextile . . . . .	S-714.13
Perforated Concrete Pipe . . . . .	S-708.05
Plastic Pipe for Underdrains . . . . .	S-708.17
Polymer Coated Corrugated Metal Pipe for Underdrains . . . . .	S-709.08
Porous Concrete Pipe . . . . .	S-708.07
Semi-circular Perforated Plastic Pipe for Underdrains . . . . .	S-708.20

**S-605.02.2--Material for Bedding and Covering.** Bedding and covering material shall conform to the requirements of S-704. Unless otherwise specified, Type C Bedding shall be used.

**S-605.02.3--Appurtenances.** Appurtenances such as flush-out units, small animal guards, signs, etc. shall be as shown on the plans and shall be of new, good commercial quality materials approved by the Engineer.



**CONSTRUCTION REQUIREMENTS****S-605.03--Pipe Installation.**

**S-605.03.1--Preparation of Trench.** Trenches shall be excavated to the dimensions and grade shown on the plans or as directed. In the event the dimensions of the trench are not indicated on the plans, the trench shall be at least as wide as the outside diameter of the pipe plus eight inches on each side, and shall be of sufficient depth to allow proper installation of the pipe and covering.

If bell and spigot pipe is used, recesses shall be cut to allow uniform bearing of the pipe on the bottom of the trench.

**S-605.03.2--Pipe Laying.**

**S-605.03.2.1--General.** Except where settlement occurs due to reasons beyond his control, the Contractor shall be responsible for the alignment and grade of pipe underdrains. Where settlement occurs due to improper excavation, bedding or backfill, negligence, or carelessness on the part of the Contractor, the pipe shall be taken up and properly relaid or replaced by him without extra compensation.

**S-605.03.2.2--Drain Tile.** Drain Tile shall be firmly embedded on the bottom of the trench, conforming to line and grade, and with the ends approximately 1/4 inch apart. If, in the judgment of the Engineer, the soil is of a composition such that it will wash into the joints, the joints shall be wrapped with strips of tarred paper approximately four inches wide. Bedding or cover material shall then be placed around the paper to prevent its displacement. No additional compensation will be allowed for this operation.

**S-605.03.2.3--Bell and Spigot Type.** Concrete pipe of the bell and spigot type shall be firmly embedded on the bottom of the trench, with the bell ends upgrade and shall have close fitting joints. No mortar will be required in the joints.

**S-605.03.2.4--Perforated Pipe.** Unless otherwise indicated on the plans, perforated pipe shall be laid with the perforated side down. Unless otherwise specified, perforated pipe shall be laid on a four-inch bed of approved filter material.

**S-605.03.2.5--Corrugated Metal Pipe.** Corrugated metal pipe shall be laid with the separate sections firmly joined together by connecting bands of an approved type.

**S-605.03.2.6--Laterals.** Laterals and other connections shall be made with suitable special sections.

**S-605.03.2.7--Dead Ends.** Dead ends of pipe underdrains shall be closed with a suitable plug of concrete placed over and around the end so as to hold the pipe securely in place.

**S-605.03.2.8--Underdrain Outlets.** When indicated on the plans, nonperforated underdrain outlets shall be joined to the underdrains.

**S-605.03.3--Appurtenances.** Underdrain appurtenances such as flush-out units, small animal guards, signs, etc. shall be constructed in accordance with the details shown on the plans and shall be of good quality workmanship.

**S-605.03.4--Pipe Covering.** After the pipe underdrain has been laid, it shall be covered immediately with the specified filter material to the dimensions shown on the plans. The remainder of the trench, if any, shall be filled with the specified material, placed in six-inch layers, and compacted to the specified density.

**S-605.04--Blind Drains.** Trenches for blind drains shall be excavated to the width and depth shown on the plans. The trench shall be filled with filter material to the depth required by the plans. The remaining upper portion of trench shall be filled with either granular or impervious material as specified. All filling material shall be thoroughly compacted, and if under the pavement structure the material shall be compacted to the density specified in the contract.

**S-605.05--Combination Storm Drain and Underdrain.** Where the plans indicate that a conduit is to serve as a combination storm drain and underdrain, the conduit shall in general be constructed in accordance with S-603. Modifications of S-603 to provide that the conduit also serve as an underdrain shall be performed under this section. Modifications shall be as shown on the plans.

The Contractor shall carefully grade and shape the compacted backfill for the lower portion of the pipe so that water entering the filter material will be adequately drained into the unsealed portion of the joints. In no case shall the surface of the compacted backfill be below the sealed portion of the joints. After the lower portion of the joint has been backfilled, compacted, and shaped as indicated above, filter material shall be placed for the full depth shown on the plans.

Each layer of filter material shall be compacted to the satisfaction of the Engineer.

Upon completion of the placement and compaction of the filter material, superimposed materials shall be placed immediately, or a temporary covering of approved material shall be placed and compacted in order to prevent unnecessary infiltration of loose material into the upper portion of the filter material.

Should appreciable contamination occur because of failure to adequately protect the surface of the filter material, that portion of the work considered to be unsatisfactory shall be removed and replaced with satisfactory work at no additional cost to the project. If temporary materials used to protect the upper portion of the filter material do not meet the requirements for the superimposed course, the temporary materials shall be carefully removed to expose clean filter materials immediately prior to placement of the required superimposed course.

**S-605.06--Filter Beds.** Excavation for filter beds shall be made to the elevation and dimensions indicated on the plans. The surface of the excavated area on which the filter bed is to be placed shall be smooth, firm, and well drained. Filter material of the types shown on the plans shall be placed, thoroughly compacted, and shaped to the dimensions indicated on the plans. Unless otherwise specified, compaction shall be to the satisfaction of the Engineer.

When impervious material or other materials are specified to be placed over the filter material, the compacted filter material shall be immediately covered with this material and compacted to the required density in accordance with S-203.

### **COMPENSATION**

**S-605.07--Method of Measurement.** Complete-in-place tile or pipe underdrains, including all special sections and connections, and blind drains will be measured from end to end by the linear foot along their center lines.

Appurtenances, specified as pay items, will be measured by the unit indicated. All necessary appurtenances not listed as pay items will not be measured for separate payment.

Excavation for pipe underdrains will be measured and paid for under the provisions of S-206 for the widths on the plans. Excavation for blind drains and filter beds will be measured and paid for in accordance with the provisions of S-203.

Measurement and payment for conduit required to be used as combination storm drain and underdrain will be made in accordance with S-603, except for those features modified as provided in this section.

Measurement for filter materials used in the construction of underdrains, combination storm drains and underdrains, and for filter beds will be made as follows:

1. In the case of underdrains and combination storm drains and underdrains, the measurement will be made complete-in-place and computed from plan dimensions. No deduction will be made for the volume occupied by pipe or portion of pipe for pipes eight inches and less in diameter. Deductions will be made for pipes larger than eight inches in diameter.
2. In the case of filter material and impervious material for filter beds, the material of the required types will be measured by the cubic yard (LVM) or ton from which will be deducted all quantities determined by the Engineer to have been placed in excess of that necessary because of the failure of the Contractor to establish and maintain the grades, lines, slopes, and other dimensions in reasonably close conformity with those shown on the plans or established by the Engineer. In computing the volume of quantities to be deducted from LVM measurement, the Engineer will determine the excess by the best procedure he deems appropriate and convert the result to LVM as provided in S-109.01.

When measurement by the ton is indicated on the plans and in the proposal, measurement will be based on the dry unit weight.

Except when specifically indicated as a pay item, no measurement for payment will be made for filter material for blind drains.

When designated as a pay item in the contract, geotextile fabric will be measured by the square yard based on plan dimensions.

**S-605.08--Basis of Payment.** Tile and pipe underdrains and blind drains will be paid for at the contract unit price per linear foot. Appurtenances listed as pay items will be paid for at the contract unit price for the units specified.

Filter material and impervious material will be paid for at the contract unit price per cubic yard or ton, as applicable.

Excavation for tile or pipe underdrains will be paid for in accordance with the provisions of S-206. Excavation for blind drains will be paid for in accordance with the provisions of S-203.

Geotextile fabric will be paid for at the contract unit price per square yard.

These prices shall be full compensation for completing the work specified.

Payment will be made under:

- S-605-A:** \_\_\_" Concrete Drain Tile for Underdrains, Class \_\_\_ - per linear foot
- S-605-B:** \_\_\_" Perforated Concrete Pipe for Underdrains,  
Class \_\_\_ - per linear foot
- S-605-C:** \_\_\_" Porous Concrete Pipe for Underdrains - per linear foot
- S-605-D:** \_\_\_" Perforated Corrugated Metal Pipe for  
Underdrains, Type \_\_\_\_\_ - per linear foot
- S-605-E:** \_\_\_" Non-perforated Corrugated Metal Pipe for  
Underdrains, Type \_\_\_\_\_ - per linear foot
- S-605-F:** \_\_\_" Bituminous Coated Perforated Corrugated  
Metal Pipe for Underdrains, Type \_\_\_\_\_ - per linear foot
- S-605-G:** \_\_\_" Bituminous Coated Non-perforated Corrugated  
Metal Pipe for Underdrains, Type \_\_\_\_\_ - per linear foot
- S-605-H Thru S-605-L:** Blank
- S-605-M:** \_\_\_" Perforated Corrugated Aluminum Pipe  
for Underdrains, Type \_\_\_\_\_ - per linear foot
- S-605-N:** \_\_\_" Non-perforated Corrugated Aluminum  
Pipe for Underdrains, Type \_\_\_\_\_ - per linear foot
- S-605-O:** \_\_\_" Perforated Sewer Pipe for  
Underdrains (SDR\_\_\_) - per linear foot
- S-605-P:** \_\_\_" Non-perforated Sewer Pipe  
for Underdrains (SDR\_\_\_) - per linear foot
- S-605-Q:** \_\_\_" Perforated Corrugated Polyethylene Drainage  
Tubing for Underdrains - per linear foot
- S-605-R:** \_\_\_" Non-perforated Corrugated Polyethylene Drainage  
Tubing for Underdrains - per linear foot

**S-605-S:** \_\_\_\_” Semi-circular Perforated Plastic Pipe  
for Underdrains - per linear foot

**S-605-T:** \_\_\_\_ " Perforated Pipe for Underdrains, Optional\* - per linear foot

\* Meeting the requirements for Pay Item Numbers 605-B, Standard Strength; 605-D, Type III; 605-M, Type III; 605-O, SDR 35, 41 or 42; 605-Q, or 605-S.

**S-605-U:** \_\_\_\_ " Non-perforated Pipe for Underdrains, Optional\*\* - per linear foot

\*\* Meeting the requirements for Pay Item Numbers 605-E, Type III; 605-N, Type III; 605-P, SDR 35, 41 or 42; or 605-R.

**S-605-V:** \_\_\_\_” Blind Drains - per linear foot

**S-605-W:** Filter Material for Combination Storm Drain and/or  
Underdrains, Type \_\_\_\_\_ - per cubic yard

**S-605-X-1:** Filter Material for Filter Beds, Type \_\_\_\_\_ - per cubic yard

**S-605-X-2:** Filter Material for Filter Beds, Type \_\_\_\_\_ - per ton

**S-605-Y-1:** Impervious Material, Type \_\_\_\_\_ - per cubic yard

**S-605-Y-2:** Impervious Material, Type \_\_\_\_\_ - per ton

**S-605-Z:** Underdrain Appurtenances(\_\_\_\_\_)  
(Description) - per each

**S-605-AA:** Geotextile for Subsurface Drainage, Type \*\*\*, AOS \*\*\*- per square yard

\*\*\* When not designated, see S-714.13.

**S-606.01--Description.** This work shall consist of furnishing and erecting complete sections of guard rail in accordance with these specifications and in reasonably close conformity with the lines and grades shown on the plans or established by the Engineer. This work shall also include the installation of reflectors on guard rail posts and the installation of guard posts.

### **MATERIALS**

#### **S-606.02--Material Requirements.**

**S-606.02.1--General.** Unless otherwise specified, all materials shall conform to the requirements shown on the plans or set forth in S-712.

**S-606.02.2--Reflectors.** Reflectors shall be of the type, size, and color designated on the plans and shall conform to the requirements of S-721.07 or S-721.08, as applicable.

**S-606.02.3--Guardrail Posts.** Unless otherwise specified guardrail posts, meeting the requirements of S-712.01, may be either wood or steel, but shall be of the same type for the entire project. All guardrail posts' materials shall conform to the dimensions and requirements as shown on the plans or as set out in these specifications.

Treated wood posts shall conform to the size and dimensions as shown on the plans and as hereinafter specified. They shall be inspected in accordance with S-718 except that the posts may be rough and shall be within  $\pm 3/8$  inch of the dimensions shown on the plans. Treatment will be in accordance with AWWA Standard C14.

Steel posts shall be of the section and length as shown on the plans and shall conform to the requirements of ASTM Designation A 36.

**S-606.02.4--Metal Rail.** Metal rail for guardrail shall conform to the requirements of AASHTO Designation M 180 and as specified on the plans.

**S-606.02.5--Guardrail Hardware.** Guardrail hardware such as bolts, nuts and washers shall conform to the requirements of S-712-03.

Swaged fittings shall meet the requirements of S-712.03.

**S-606.02.6-Terminal End Sections.** Terminal end sections, installed as per manufacturer's recommendations, shall be National Cooperative Highway Research Program (NCHRP) Report 350 Test Level 3 (TL-3) approved.

The Contractor shall furnish the Project Engineer two (2) copies of the manufacturer's installation instructions prior to beginning guard rail operations.

### **CONSTRUCTION REQUIREMENTS**

**S-606.03--Erection of Guard Posts.** The posts shall be set plumb and firm to the depth indicated and accurately lined, spaced, and graded. After the posts are in place, the holes shall be backfilled with suitable material which shall be thoroughly compacted in approximate six inch layers by tamping. Posts shall not be sawed or cut after treatment. If set posts are found to be in improper position with reference to alignment or grade, they shall be removed and reset properly, except that if found to be high they may be driven to the proper elevation provided the tops of the posts are protected by suitable driving caps.

Wood guard rail posts and guard posts may be erected by driving or by a combination of drilling and driving when after demonstration at the project site the Engineer approves the results as being equal to or better than the results that can be obtained by erecting posts in drilled holes and backfilling. Acceptability of driving or combined drilling-driving will be contingent on the following conditions:

1. Use of approved (and proven) mechanical driving equipment;
2. Maintenance of acceptable results without impairing the structural integrity of adjacent materials or structures;
3. Use of drills to penetrate courses that may resist penetration by driving. When drills of nominal post-size are used the void between the post and the edges of the hole shall be filled with Grade AC-13 or equivalent asphalt. Holes larger than nominal post-size drilled through paved surfaces or cement treated courses shall be properly backfilled with hot or cold bituminous pavement;
4. Out-of-tolerance posts shall be pulled and properly replaced or reset, and all disrupted portions of the roadbed structure restored as directed; and
5. Mutilated posts shall be pulled and properly replaced, and all disrupted portions of the roadbed structure restored in kind or as directed.



Steel posts may be erected by driving, provided an approved driving head is used.

The top inside edges of posts shall be set within 1/4 inch of correct vertical and horizontal alignment.

Guard rail posts on bridges shall be plumb and accurately spaced and lined.

Where sections of rail are located on curves, the posts shall be erected so as to obtain the designated panel lengths measured along the face of the rail.

**S-606.04--Anchorage.** Anchors and braces shall be furnished and placed as shown on the plans.

**S-606.05--Erection of Rails.** All fabrication and forming of rail elements shall be completed prior to application of the shop paint. Field punching, cutting, burning, or welding will not be permitted, except where specifically authorized by the Engineer and subject to the conditions of his authorization.

The rail shall be erected in a manner resulting in a smooth, continuous, taut rail conforming to the line and grade shown on the plans or established. In the erection of rail, consideration shall be given to the prevailing temperature and the anticipated rise and fall of temperature ultimately affecting the length of the rail.

Where required, ends of rail shall be flared within the limits shown on the plans or established.

Bolts and clips used for fastening rails or fittings to posts shall be drawn up tightly, and all bolts, except "take up" device bolts, shall be of such length as to not project beyond the nut more than the limits shown on the plans. Sawing off ends of bolts to meet this requirement will be permitted.

**S-606.05.1--Additional Provisions for Guard Rail Construction.** On any facility opened to traffic, the Contractor shall not begin work on any section of guard rail until preparations have been made to complete the installation of the section, including posts, rail, anchors, and hardware as a continuous operation. Once work has been initiated on a section, the work shall be prosecuted to its completion unless inclement weather or other conditions beyond the control of the Contractor interfere with the work. Incomplete guard rail or special end sections shall not be left exposed to the traveling public without the approval of the Engineer. If approval is granted, the incomplete section must satisfactorily be marked with drums, barricades, or other devices, as directed by the Engineer, at no additional cost. In no case will incomplete guard rail or special end sections be allowed to remain over a weekend or holiday period.

**S-606.06--Repairing Rails and Fittings.** Where the galvanizing on guardrail or fittings has been damaged, the coating shall be repaired by re-galvanizing or the surface repaired by painting with two coats of zinc oxide paint approved by the Engineer.

**S-606.07--Reflectors.** Reflector units shall be installed in conformity with details shown on the plans and in accordance with the manufacturer's recommendations. Where holes are required to be bored in posts or other units, the holes shall be bored prior to the required painting. The reflectors shall be installed after all painting is completed.

### **COMPENSATION**

**S-606.08--Method of Measurement.** Guard rail, complete in place, will be measured by the linear foot along the face of the rail from center to center of end posts for each complete section and will include posts and other elements of the completed section.

Special sections will be measured per each complete-in-place, or linear foot, as indicated on the plans.

Guard posts will be measured by the unit per each post installed. Such measurement will include reflectors as specified, backfill, clean up, and any required additional hardware such as caps and chain necessary to complete the work.

**S-606.09--Basis of Payment.** Guard rail will be paid for at the contract unit price per linear foot for each designated type. Special sections will be paid for at the contract unit price per linear foot or per each, as applicable. Guard posts will be paid for at the contract unit price per each (with reflectors if specified).

These prices shall be full compensation for completing the work specified.

Payment will be made under:

**S-606-A:** Guard Post - per each

**S-606-B:** Guard Rail, \_\_\_\_\_ - per linear foot  
(Designation)

**S-606-C:** Guard Rail, Cable Anchor, \_\_\_\_\_ - per linear foot  
(Designation)

**S-606-D:** Guard Rail, Bridge End Section, \_\_\_\_\_ - per each  
(Designation)

**S-606-E:** Guard Rail, Terminal End Section - per each

**S-606-F:** Special Sections, \_\_\_\_\_ - per linear foot  
(Designation)

**Section S-607 - Blank.**

**S-608.01--Description.** This work shall consist of constructing portland cement concrete sidewalk or driveway on a prepared subgrade in accordance with the plans and specifications. Lines and grades shall be as shown on the plans or established. "Subgrade" in this section shall mean the prepared foundation on which the sidewalk or driveway is constructed.

### **MATERIALS**

**S-608.02--Material Requirements.** All material furnished for use shall comply with appropriate requirements of the S-700 series of these specifications, and the following:

Concrete shall be Class B meeting the requirements of S-804.

Reinforcing steel shall meet the applicable requirements of S-602 and S-711 and plan details.

Expansion joint filler shall be either premolded or poured and shall conform to the requirements as set forth in S-707 for the particular type specified.

### **CONSTRUCTION REQUIREMENTS**

**S-608.03--Equipment.** The Contractor may use forms or, if requested in writing and approved by the State Aid Engineer, an approved automatic extrusion type paving machine.

Forms shall be wood or metal. If wood, they shall be dressed on all sides, and be free of bulges, warps and loose knots. If metal, they shall be of approved section and have a flat surface on top. The depth of the forms shall be equal to the depth of the sidewalk or driveway. Adequate means shall be provided for securely fastening the ends of forms together.

Prior to use, an automatic extrusion machine must be demonstrated to produce a consolidated concrete section conforming to the dimensions, cross section, line, and grades shown on the plans or established.

**S-608.04--Excavation and In-Grade Preparation.** Excavation shall be made to the required depth and to a width that will permit the installation and bracing of forms. The foundation shall be shaped and compacted at the proper moisture content to a firm, even surface conforming to the lines, grades, and sections shown on the plans or established. All soft, spongy, or other unsuitable materials encountered shall be removed and replaced with acceptable material.

**S-608.05--Setting Forms.** Forms shall be set to the required line and grade and rigidly held in place by stakes or braces. Ends of adjoining form sections shall be flush. Forms and division plates shall be cleaned and oiled before placing concrete against them.

**S-608.06--Handling, Measuring, Proportioning and Mixing Materials.** The method of handling, measuring, proportioning and mixing concrete materials shall conform to S-804. Where reinforcement is required, it shall be placed in accordance with S-602.

**S-608.07--Placing Concrete.** A template resting upon the side forms and having its lower edge at the elevation of the subgrade shall be drawn along the forms to shape and grade the subgrade before concrete is deposited. The subgrade shall be moist and free of debris and foreign material before concrete is deposited upon it. The concrete mixture shall be placed on the prepared subgrade to the depth required to complete the sidewalk or driveway in one course. It shall then be vibrated and/or tamped and struck off with an approved straightedge resting upon the side forms and drawn forward with a sawing motion. The surface shall be given a Class 6 float finish as set out in S-804.

The edges of sidewalk shall be rounded with an edging tool having a radius of 1/2 inch. Expansion joints shall be edged with an edger having a radius of 1/4 inch.

The edges of driveways at expansion joints shall be edged with an edger having a radius of 1/2 inch. Curb returns shall be finished as specified for integral curb in S-609.

**S-608.08--Joints.** Expansion joints shall be of the dimensions specified and shall be filled with the type of premolded expansion joint filler specified. Sidewalks shall be divided into sections by dummy joints formed by a jointing tool or other acceptable means. These dummy joints shall extend into the concrete for at least one inch and shall be approximately 1/8 inch wide. Joints shall match as nearly as possible adjacent joints in curb or pavements. Dummy joints may be sawed in lieu of forming with a jointing tool.

Construction joints shall be formed around all appurtenances such as manholes, utility poles, etc. extending into and through the sidewalk. Premolded expansion joint filler 1/4 inch thick shall be installed in these joints. Expansion joint filler of the thickness indicated shall be installed between concrete sidewalks and fixed structures such as a building or bridge. This expansion joint material shall extend for the full depth of the sidewalk.

**S-608.09--Protection and Curing.** Concrete shall be protected and cured in accordance with the requirements of S-804.03.17 or by other approved methods.

Placement, protection, and curing of concrete during cold or hot weather shall conform to the limitations, conditions, and requirements set out in S-804.

**S-608.10--Backfilling and Cleaning Up.** When the concrete has set sufficiently, all forms, bracing, etc., shall be removed and the sides of the sidewalk or driveway shall be backfilled and compacted to the required elevation with suitable material. All surplus material shall be disposed of as directed, and the completed work and the site shall be left in a neat and presentable condition.

**COMPENSATION**

**S-608.11--Method of Measurement.** Completed and accepted concrete sidewalks and driveways will be measured for payment by the square yard.

Excavation, backfill, expansion joint material, and other miscellaneous items will not be measured for separate payment.

**S-608.12--Basis of Payment.** Concrete sidewalks and driveways will be paid for at the contract unit price per square yard, which shall be full compensation for completing the work specified.

Payment will be made under:

**S-608-A:** Concrete Sidewalk - per square yard

**S-608-B:** Concrete Driveway - per square yard

**S-609.01--Description.** This work shall consist of constructing curb, gutter, and combination curb and gutter in accordance with these specifications and in reasonably close conformity with the lines, grades, dimensions, and cross sections shown on the plans or as established.

### MATERIALS

**S-609.02--Material Requirements.** Concrete for curb, gutter, and combination curb and gutter shall meet the requirements of S-601.

Mixtures for bituminous curb shall be in accordance with S-401 and S-403 and unless otherwise specified, or approved, shall be a Type ST, 12.5 mm mixture.

### CONSTRUCTION REQUIREMENTS

**S-609.03--Excavation and Grade Preparation.** Excavation and grade preparation for gutter, curb, and combination curb and gutter shall be performed in accordance with the applicable provisions of S-205.

#### **S-609.04--Cast-in-Place Portland Cement Concrete.**

**S-609.04.1--Forms.** Forms, except for divider plates and templates, may be wood or metal. All forms shall be full depth, straight, and free of warp and shall be securely staked, braced, and sufficiently tight to prevent leakage of mortar. All forms shall be cleaned thoroughly and oiled before placing concrete against them.

Lumber for wood forms shall be sound, free of bulges, loose knots, and warps, and of uniform width. All lumber shall be dressed and at least two inches (commercial) thick, except the Engineer may permit the use of flexible material on short radii.

Metal forms shall be approved sections and shall have a flat surface on top. They shall present a smooth surface and be of sufficient strength when braced to withstand the weight of the concrete without bulging or displacement. Special care shall be exercised to keep metal forms free from rust, grease, or other foreign matter which would discolor the concrete.

Metal templates or dividing plates shall be of sufficient thickness and of such design as to hold the forms rigidly in place and to produce a smooth vertical joint after the plates are removed. They shall be of the full dimensions shown on the plans for curb, gutter, or combination curb and gutter.

**S-609.04.2--Proportioning, Mixing, and Placing Concrete.** Unless otherwise specified, concrete used for curb, gutters, and combination curb and gutter shall be Class "B" proportioned, mixed, and placed in accordance with the provisions of S-601.

The concrete shall be placed on a moist grade and consolidated by vibration or other acceptable methods. Weep holes shall be placed through curbs where indicated on the plans or as directed.

**S-609.04.3--Extruded Construction.** Concrete curb and curb and gutter may be constructed by the use of a curb forming machine. Such a machine shall conform to Parts 1, 2, and 5 of S-609.05.2, and in addition, its continued use shall be contingent upon it producing curb with the specified section, line, and grade. If these conditions cannot be met, construction shall be by conventional methods.

In the event a curb forming machine is used, the Mississippi Department of Transportation Testing Engineer, or other approved testing laboratory, may make minor modifications in the concrete mix design to improve placement.

**S-609.04.4--Sections and Joints.** Concrete curb, gutter, or combination curb and gutter shall be constructed in uniform sections of the length specified on the plans. These lengths may be reduced where necessary for closure but no section less than six feet will be permitted. The templates shall be accurately set before placing the concrete and allowed to remain in place wherever possible until the concrete has set sufficiently to hold its shape, but shall be removed while the forms are still in place.

Expansion joints shall be formed of premolded joint filler of the specified thickness, and shall be placed in line with expansion joints in the adjoining pavement or structure and at other locations designated on the plans. All joint fillers shall be cut to full cross section and shall extend for full depth, width, and length. All expansion joint material protruding after the concrete is finished shall be trimmed as directed. Immediately after removal of forms, the outer edges of filled joints shall be carefully exposed.

**S-609.04.5--Finishing.** The concrete shall be finished smooth and even by a wood or other approved float. Forms on the face of curbs shall be removed as soon as the concrete will hold its shape, and the surface shall be finished with a wood float to a smooth even texture. Plastering will not be permitted. Strikeoff templates of the form and shape of the gutter shall be used to shape the top surface of gutters. Before final finishing the surface of gutters shall be checked with a ten (10) foot straightedge, and all irregularities of more than 1/8 inch in ten (10) feet shall be corrected. Edges on the faces of curbs shall be rounded with finishing tools having the radii shown on the plans. Edges where templates have been removed or expansion joint material has been placed shall be finished with an edging tool having a radius of 1/4 inch.



All exposed surfaces against which some rigid type of construction is to be made shall be left smooth and uniform so as to permit free movement of the curb, gutter, or combination curb and gutter.

All tool marks shall be removed with a wetted brush or wood float. The finished surface shall be a uniform color free from discolorations.

**S-609.04.6--Protection and Curing.** Concrete shall be cured for at least seventy-two (72) hours. Curing shall be by moist cotton or burlap mats, waterproof paper, white polyethylene sheeting, or by other approved methods.

The Contractor shall have materials available at all times for the protection of unhardened concrete against rain. During the curing period all traffic, both pedestrian and vehicular, shall be kept off the concrete. Vehicular traffic shall be kept off for such additional time as the Engineer may direct. The Contractor shall protect the work from damage until final acceptance. All sections which are damaged before final acceptance shall be removed and reconstructed by the Contractor without extra compensation.

**S-609.05--Bituminous Curbing.**

**S-609.05.1--Preparation of Bed.** When curbing is to be constructed on a newly placed bituminous surface, the curb may be laid if the surface is clean.

When curbing is to be constructed on portland cement concrete or on bituminous base or pavement that is not newly placed, the bed shall be thoroughly swept and cleaned by compressed air. The surface shall be dry, and immediately prior to placement of the curb shall be tacked with bituminous material of the type and grade approved by the Engineer. The rate of application of the tack coat material shall be between 0.05 to 0.15 gallons per square yard of surface. The Contractor shall prevent the tack coat material from spreading to areas outside that to be occupied by the curb.

**S-609.05.2--Placing.** Bituminous curbing shall be constructed with a self-propelled curbing machine or paver with curbing attachments designed to extrude and compact the material in accordance with the typical section on straight and curved alignments.

The automatic curb machine shall meet the following requirements and shall be tentatively approved prior to its use. Continued use shall be contingent upon its production of curbing meeting the specified requirements.

1. The weight of the machine shall be such that the required compaction is obtained without the machine riding above the specified grade.
2. The machine shall be capable of laying the curb to the dimensions and position specified.
3. The machine shall be capable of ironing the curbs smoothly with a heat-jacketed mold and of compacting the curb to at least ninety (90) percent of theoretical density.
4. When curbing is to be placed on an existing bituminous surface the machine shall be capable of pre-heating the surface.
5. The machine shall form curbing that is uniform in texture, shape, and density.
6. The Engineer may permit construction by other means for short sections or sections with short radii or for other reasons as may seem to be warranted. The resulting curbing shall conform in all respects to the curbing produced by the use of the machine.

**S-609.05.3--Painting.** When painting is required, it shall consist of two coats of the specified traffic paint meeting requirements of S-619. Glass beads shall also conform to the requirements of S-619 and shall be applied onto the top coat of paint in a manner that will embed the beads sufficiently to adhere to the painted surface.

**S-609.06--Backfilling and Cleaning Up.** After the concrete has set sufficiently or the bituminous curb has cooled, the areas on the sides of the curb, gutter, and combination curb and gutter shall be filled to the required elevation with the specified materials and compacted as specified or directed.

All surplus material shall be disposed of as directed, and the entire area shall be left in a neat and satisfactory condition.

### **COMPENSATION**

**S-609.07--Method of Measurement.** Complete-in-place concrete gutter, curb, and combination curb and gutter and bituminous curb will be measured by the linear foot along the face of the curb or flow line of gutter. Deduction will be made for driveway openings.

Concrete integral curb, complete in place, will be measured by the linear foot along the face of the curb including the full length of curb return for driveways.

No deduction in length will be made for drainage structures such as catch basins and inlets installed in the curbing.

Excavation backfill, expansion joint material, and other related miscellaneous items will not be measured for separate payment. The cost thereof shall be included in the unit prices bid for other items.

**S-609.08--Basis of Payment.** This work will be paid for at the contract unit prices per linear foot, complete in place, which shall be full compensation for completing the work specified.

Payment will be made under:

<b><u>S-609-A:</u></b>	Concrete Gutter ( _____ ) (Designation)	- per linear foot
<b><u>S-609-B:</u></b>	Concrete Curb, Type _____	- per linear foot
<b><u>S-609-C:</u></b>	Concrete Curb (Integral) Type _____	- per linear foot
<b><u>S-609-D:</u></b>	Combination Concrete Curb and Gutter*	- per linear foot
<b><u>S-609-E:</u></b>	Bituminous Curb	- per linear foot

\* Type may be specified.

### **Section S-610 - Blank**

**S-611.01--Description.** This work shall consist of constructing brick masonry structures in accordance with these specifications and in reasonably close conformity with the lines, grades, dimensions, and details shown on the plans or as directed.

### **MATERIALS**

**S-611.02--Material Requirements.** Masonry brick shall be new, whole brick of standard commercial size with straight and parallel edges and square corners. They shall be Grade SW or Grade SM as specified and shall meet the requirements of S-706.01.

Unless otherwise specified, the following use requirements shall govern:

- (a) Grade SW brick shall be used in exposed masonry.
- (b) Grade SM brick shall be used in catch basins, inlets, manholes, and other sewer or drainage structures.

Mortar for brick masonry shall conform to the applicable requirements of S-714.11.

### **CONSTRUCTION REQUIREMENTS**

**S-611.03--Excavation.** Excavation for brick masonry shall be performed in accordance with the provisions of S-604.03.8.

**S-611.04--Laying Brick.** Brick masonry shall not be constructed in freezing weather or when bricks contain frost except by written permission of the State Aid Engineer and subject to the conditions he may require.

Brick for exposed surfaces, corners, etc., shall be selected for color and uniformity.

Mortar shall be mixed only in quantities required for immediate use. Unless an approved mortar mixing machine is used, the sand and mortar mix, or cement and lime, shall be mixed dry in a tight box until the mixture assumes a uniform color, after which water shall be added as the mixing continues until the mortar attains the proper consistency. Mortar which is not used within forty-five (45) minutes after water has been added shall be wasted. Retempering of mortar will not be permitted.

Brick shall be laid upon prepared foundations in accordance with the design indicated on the plans or as directed. All brick shall be thoroughly clean and saturated with water immediately prior to laying.

They shall be laid in courses and in a manner that will thoroughly bond them into the fresh mortar by means of the "shove joint" method. "Buttered" or plastered joints will not be permitted. The arrangement of headers and stretchers shall be that which will thoroughly bond the mass. Unless otherwise specified, brick work shall be of alternate headers and stretchers with consecutive courses breaking joints. Other types of bonding, such as for ornamental work, will be specified on the plans.

All joints shall be completely filled with mortar. They shall not be less than 1/4 inch nor more than 1/2 inch in thickness, and the thickness shall be uniform throughout. All joints shall be finished properly as the work progresses, and on exposed walls they shall be neatly struck using the "weather" joint.

Bats or spalls shall not be used except for shaping around irregular openings or when unavoidable to finish out a course. When used to finish out a course, full bricks shall be placed at the corners and the bats placed in the interior course. Filling materials for the interior of the walls shall be the same quality as used in the face of the unit unless otherwise indicated on the plans or directed.

Weep holes shall be constructed as shown on the plans or as directed.

In case a brick is moved or the joint broken after laying, the brick shall be taken up, the mortar thoroughly cleaned from the brick bed and joint, and the brick relaid in fresh mortar.

In hot or dry weather, brick masonry shall be protected and kept wet for a period of at least forty-eight (48) hours after the brick are laid.

Only expert brick-layers shall be used for this work, and all details of the construction shall be in accordance with approved and satisfactory practice.

All exposed masonry shall present an even, uniform, neat, and workmanlike appearance, and the exposed surfaces shall be thoroughly cleaned of all mortar and scars and the surface left the natural color of the brick.

**S-611.05--Backfill.** Backfill for brick masonry shall be in accordance with the provisions of S-203.09.3.3.

**COMPENSATION**

**S-611.06--Method of Measurement.** Brick masonry will be measured by the cubic yard or by the thousand (M). The unit for measurement will be indicated on the proposal.

When measurement is by the cubic yard, the volume will include the mortar.

When measurement is by the thousand (M), the mortar will not be measured for payment.

When either concrete masonry or brick masonry is permitted under S-604.03.4, measurement will be made in accordance with S-604.04.

Excavation for brick masonry will not be measured for payment.

**S-611.07--Basis of Payment.** Brick masonry will be paid for at the contract unit price per cubic yard or per thousand (M), as indicated, which shall be full compensation for completing the work specified.

When brick masonry is used as an optional item of construction under S-604.03.4, payment will be made as provided in S-601.17.

Payment will be made under:

**S-611-A:** Brick Masonry - per cubic yard

**S-611-B:** Brick Masonry - per thousand (M)

**S-612.01--Description.** This work consists of locating unstable concrete or other pavement, voids, drilling of holes and the pumping of a slurry type grout mixture to stabilize and underseal the pavement voids. The grout mixture shall form a hard and insoluble mass that will effectively fill the voids. Pavement that remains unstable after an initial undersealing and stabilizing attempt shall be re-grouted as directed by the Engineer.

When a hot mix asphalt overlay is required, it shall be the Contractor's responsibility to schedule operations in such a manner that the first course of overlay will be placed at the earliest practicable time and no later than fourteen days after the pavement has been stabilized.

When designated on the plans, this work shall also consist of drilling holes in the shoulder adjacent to cracks at the edge of the pavement and the pumping of a slurry type grout mixture to fill the cracks to the surface of the cement treated shoulder. Unless otherwise specified, Type 1 grout shall be used. If in the Engineer's opinion, the type of grout being used proves to be unsatisfactory, the Contractor shall switch to a Type 5 grout at no change in contract price.

**S-612.02--Materials.** shall meet the follows requirements:

Materials used in the work shall meet the requirements specified in the following sections or subsections:

Portland Cement Types I or III .....	S-701
Calcium Chloride, Type I .....	S-714.02*
Fly Ash, Class C or F .....	S-714.05
Water.....	S-714.01.1 and S-714.01.2
Fine Aggregate .....	S-703.18**
Limestone Dust .....	S-612.02.1

\* The Engineer may approve other commercially available accelerators which may be substituted for calcium chloride.

\*\* Fine aggregate shall meet the requirements of S-703.18 except that mortar making properties are not required.

**S-612.02.1--Limestone Dust.** The source of the material shall be approved by the Engineer and meet the following gradation requirements:

<u>SIEVE</u>	<u>PERCENT PASSING</u>
No. 30 .....	95-100
No. 200 .....	20-100

**S-612.02.2--Proportioning Grout Mixture.** The bid item will designate the type or types of grout mixture which shall consist of proportions listed in the table below. The mixing water shall be that quantity which will produce a grout of such consistency that the time of efflux from the flow cone will be a minimum of 16 seconds and a maximum of 22 seconds. Upon approval of the Engineer, a wetting agent may be added to the water to reduce surface tension and increase flowability of the grout mixture.

The consistency will be determined by Mississippi Test Method MT-56. Cement, fly ash, limestone dust, and/or fine aggregate may be added in the proper proportions to a mixed batch to produce the required consistency provided the cement factor is not reduced to less than specified.

**GROUT MIXTURES**  
**PERCENT BY WEIGHT OF DRY MATERIALS**

<b><u>DRY MATERIALS</u></b>	<b><u>TYPES</u></b>					
	<b><u>1</u></b>	<b><u>2</u></b>	<b><u>3</u></b>	<b><u>4</u></b>	<b><u>5</u></b>	<b><u>6</u></b>
Cement	25	25	25	25	30	25
Limestone Dust		25	75	50		
Fly Ash	25			25	70	
Fine Sand	50	50				75
Calcium Chloride	*	*	*	*	*	

\* As prescribed in S-612.03.1

It shall be the Contractor's responsibility to have the grout mixture in its final position within one hour after adding the mixing water.

**S-612.03--Construction Requirements.**

**S-612.03.1--Weather Limitations.** Pressure grouting shall not be performed when the subgrade contains an abnormal amount of moisture as evidenced by standing water on the pavement or in joints or cracks. The air temperature shall be above 40°F in the shade or 35°F and rising before starting any grout pumping operation.



The following temperature ranges shall control the quantity of calcium chloride to be included in the grout mixture:

<u>ATMOSPHERIC TEMPERATURE</u>	<u>PERCENT CALCIUM CHLORIDE BY WEIGHT OF CEMENT</u>
35 - 55°F	5
56 - 69°F	4
70 - 79°F	3
80 - 89°F	2
90°F and above	1

The quantity shall be as prescribed unless otherwise directed by the Engineer. Upon approval of the Engineer, the calcium chloride may be reduced in quantity or eliminated as required with the use of Class "C" fly ash. The calcium chloride shall be thoroughly pre-mixed in the mixing water.

**S-612.03.2--Equipment.** The equipment shall be that customarily used in pressure grouting of earthen embankments or mud-jacking of concrete pavement. It shall consist of no less than the following:

- (a) Air compressors of sufficient capacity for operating pneumatic equipment.
- (b) Pneumatic equipment with a drill size that is compatible with the size of the pump discharge nozzle. The equipment shall be in satisfactory operating condition and operated in such a manner as to prevent unnecessary damage to the pavement.
- (c) Equipment for accurately measuring and proportioning by volume or weight the component materials of the grout.
- (d) A mixer capable of thoroughly mixing the grout in an approved manner. A batch type and concrete mixing trucks may be used for types 2 and 3 grout mixtures. A colloidal mixer must be used for Types 1, 4 and 5 grout mixtures.
- (e) A positive action pump capable of forcing grout into voids and cavities beneath the pavement. The pump shall be capable of producing a discharge pressure range of 50 to 200 pounds per square inch of the end of the discharge pipe. The pumping system shall be equipped with a pressure gauge so that any instantaneous change in pressure can be detected by the inspector.
- (f) A stop watch and flow cone conforming to the dimensions and other requirements set out in the MDOT's SOP for Mississippi Test Method: MT 56.

- (g) Testing equipment shall consist of a tandem axle truck with dual wheels and the rear axles shall be loaded to 50 kips evenly distributed. The measuring equipment shall consist of no less than two gages mounted on a measuring device that is capable of detecting movement of 0.001 of an inch. A driver and sufficient personnel to assist in preliminary testing, when required by the contract, and stability testing.
- (h) Equipment to measure pavement lift shall consist of no less than four gages mounted on a measuring device or devices that is capable of detecting movement on each side of a joint or crack and the adjoining shoulder simultaneously. The equipment shall make such measurements to 0.001 of an inch.

### **S-612.03.3--Testing.**

**S-612.03.3.1--General.** When testing is required, it is intended to locate all pavement having a deflection exceeding 0.030 of an inch. Testing may begin as early as 4:00 A.M. and continue as long as the surface temperature of the pavement remains below 85°F.

**S-612.03.3.2--Preliminary Testing by the Engineer.** When the pavement has been tested and marked by the Engineer, preliminary testing will not be required by the Contractor.

**S-612.03.3.3--Preliminary Testing by the Contractor.** When the contract includes a unit bid price for testing and it has not been performed by the Engineer, all of the project or designated areas shall be tested by the Contractor. Testing shall be performed as follows:

One set of gages will be positioned on each side of a joint or crack near the pavement edge. The gages will be zeroed with no load on either side of the joint or crack. The test truck will then be moved into position and stopped with the center of the nearest test axle about one foot from the joint or crack and the outside test wheel about one foot from the pavement edge. The gages will be read and the test truck will then be moved across the joint or crack to a similar position for a second reading of the gages. This operation will be repeated for each joint or crack to be tested. The inspector will be responsible for reading the gages and subsequent recording. All locations with movement of more than 0.030 of an inch will require pressure grouting.

When testing shoulders, gauge positioning and testing shall be the same as indicated above for roadway pavement. The Engineer may adjust the position of the gages to meet field conditions.

**S-612.03.3.4--Stability Testing.** After the designated areas have been pressure grouted in accordance with these specifications, they shall be retested in accordance with S-612.03.3.3 when the contract includes a unit bid price for testing.

Any undersealed pavement with movement of 0.030 of an inch or more shall be re-grouted and tested as directed.

Any pavement which continues to show movement in excess of that specified after two properly performed groutings may be accepted, or the slab may be removed and replaced as directed by the Engineer.

**S-612.03.4--Drilling Holes.** The hole pattern and pumping sequence shown on the plans shall be used, except when modified to use drilling holes made from previous undersealing work. The Contractor may alter the hole pattern with the Engineer's approval. However, only the actual number of holes drilled will be measured for payment.

The holes shall be of a size and shape that best provide a positive seal for the pumping nozzle. The holes shall be drilled to a depth of approximately eight inches below the bottom of the concrete for the initial undersealing unless the Engineer approves an alternate depth. The number, depth and location of holes for undersealing after the initial operation shall be approved by the Engineer.

When pressure grouting cracks located in the shoulders at the edge of the pavement, the holes in the shoulders shall be located as shown on the plans or as directed by the Engineer. These holes are to be drilled below the treated base.

**S-612.03.5--Cleaning Holes.** Prior to pumping the grout, compressed air shall be used to remove debris and to help provide a passage for the grout.

**S-612.03.6--Pumping the Grout.** The nozzle of the discharge hose shall be secured in the hole in a manner that provides a seal adequate to maintain the grout pressure underneath the slab. The nozzle end shall not extend below the bottom of the concrete. Pumping will continue until a clear flow of grout protrudes from an adjacent hole, joint or crack, or until the pavement begins to lift. This procedure will be repeated in other holes until all voids are supposedly filled. Plugging of holes during grouting operations will not be permitted.

Additional evidence that grouting should cease is a rapid rise of the pavement, or a rise of the adjacent shoulder. A minimum lifting of the pavement will generally be required to move grout into the cavities and voids, however, the lifting shall not exceed 0.050 of an inch. Movement of the pavement and adjacent shoulder will be monitored by the Contractor with equipment as required by S-612.03.2(h). Care shall be taken not to crack the pavement by differential lifting. During pumping, very close attention shall be given to the lift measuring device to prevent excessive pumping pressures.

Moderate to major pavement cracks or pavement broken during the pumping operation due to the Contractor's negligence will be repaired or removed and replaced at the Contractor's expense.

**S-612.03.7--Clean Up and Opening to Traffic.** Deposits of mud and/or grout on the pavement or shoulders shall be removed and the surface cleaned before traffic is permitted on the section. Other debris, bags, spillage, etc., shall be removed from the right-of-way each day.

Traffic shall not use the undersealed pavement for at least three hours after grouting. Grouting operations shall cease at least three hours before sundown or earlier as necessary to permit the grout to harden at least three hours.

**S-612.03.8--Permanently Sealing Holes.** When pavement is not to be overlaid all grout shall be removed from the holes to the bottom surface of the concrete pavement and filled with a stiff sand-cement mixture or an approved quick setting patching material. Filled holes that ravel out or become damaged shall be repaired. All holes from previous undersealing work that were used by the Contractor shall also be similarly repaired at no cost to the Project.

**S-612.03.9--Stability Tests.** The test shall not be conducted until the undersealed pavement has been open to traffic for at least twelve hours. These tests shall be conducted in accordance with S-612.03.3.4. Based upon these test results the pavement will be accepted or designated for further undersealing or replaced as directed by the Engineer.

**S-612.04--Method of Measurement.** Holes drilled at locations and to the depths shown on the plans or directed by the Engineer will be measured per each. Additional holes required for subsequent undersealing operations will be measured per each.

Portland Cement incorporated into the grout mixture will be measured by the pound.

Calcium chloride incorporated into the completed work in accordance with the provisions of the contract will be measured by the pound.

When required, preliminary testing in accordance with S-612.03.3.3 will be measured by the mile, linear horizontal measure, for each lane of roadway.

Stability testing at each joint or crack in accordance with S-612.03.3.4 will be measured per each lane joint or each lane crack, up to a maximum of three tests.

**S-612.05--Basis of Payment.** Holes will be paid for at the contract unit price per each, which price shall be full compensation for drilling and sealing the hole.

The portland cement and calcium chloride incorporated into the grout mixture will be paid for at the contract unit price per pound, which price shall be full compensation for furnishing materials to be incorporated into the specified type of grout mixture, for all hauling, mixing, pumping and clean-up required to stabilize the pavement.

Preliminary testing will be paid for at the contract unit price per mile, which price shall be full compensation for furnishing all testing equipment, the load test truck and necessary personnel to assist in the testing.

Stability testing will be paid for at the contract unit price per each test and shall be full compensation for furnishing all testing equipment, the load test truck and necessary personnel to assist in the testing.

Payment will be made under:

<b><u>S-612-A:</u></b>	Holes *	- per each
<b><u>S-612-B:</u></b>	Portland Cement Pressure Grout Slurry, Type _____	- per pound
<b><u>S-612-C:</u></b>	Calcium Chloride	- per pound
<b><u>S-612-D:</u></b>	Preliminary Testing	- per mile
<b><u>S-612-E:</u></b>	Stability Testing, Lane Joint	- per each
<b><u>S-612-F:</u></b>	Stability Testing, Lane Crack	- per each

\* Indicate "In Shoulders" when holes are required in shoulders

STAT SECTION S-613 - ADJUSTMENT OF CASTINGS, GRATINGS AND 2004  
UTILITY APPURTENANCES

**S-613.01--Description.** This work shall consist of furnishing all materials and adjusting existing catch basins, inlets, manholes and other designated structures in accordance with these specifications and in reasonably close conformity with the lines, grades and dimensions shown on the plans or as established.

**MATERIALS**

**S-613.02--Material Requirements.** New materials used in this construction, unless otherwise stipulated, shall conform to the requirements set out in S-604.

**CONSTRUCTION REQUIREMENTS**

**S-613.03--General.** Construction requirements shall be, insofar as applicable, as described in S-604. Castings, gratings, frames, covers, and other metal units shall be cleaned before resetting.

Where a casting, grating, or utility appurtenance is to be lowered, the masonry shall be removed to sufficient depth so that a set of proper dimensions may be reconstructed to receive the castings, grating or utility appurtenance at the new grade. Where the casting, grating or utility appurtenance is to be raised less than one foot, a new ring of masonry may be added without disturbing the old masonry. Where the distance to be raised exceeds one foot, the old masonry shall be removed to sufficient depth, as directed, to permit a neat and workmanlike extension to the new grade.

The Contractor shall replace at his own expense all units or parts indicated to be salvaged and reused which are damaged as a result of his operation.

**S-613.04--Cleaning Up.** Upon completion of the adjustment, all surplus material shall be removed, and the structure and site of the work shall be left in a neat and clean condition. The entire structure shall be thoroughly cleaned of accumulations of silt, debris, or foreign matter of any kind and shall be kept clean until the final inspection.

**S-613.05--Method of Measurement.** Acceptably adjusted castings, gratings, and utility appurtenances for which pay items are included in the contract will be measured on a lump sum basis or by the number of units, as specified.

**CONSTRUCTION REQUIREMENTS**

**S-613.06--Basis of Payment.** Adjustment of castings, gratings, and utility appurtenances for which pay items are included in the contract will be paid for at the contract lump sum price or at the contract unit price per each, as indicated, which shall be full compensation for completing the work specified.

Payment will be made under:

- S-613-A:** Adjustment of Castings, Gratings and Utility Appurtenances - per lump sum
- S-613-B:** Adjustment of Castings - per unit
- S-613-C:** Adjustment of Gratings - per unit
- S-613-D:** Adjustment of \_\_\_\_\_ - per lump sum  
(Description)
- S-613-E:** Adjustment of \_\_\_\_\_ - per unit  
(Description)

**Sections S-614 and S-615 - Blank.**

**S-616.01--Description.** This work shall consist of furnishing all materials and constructing paved islands on a prepared grade in accordance with these specifications, at the locations specified and in reasonably close conformity with the lines, grades, and typical sections shown on the plans or as established. When so indicated on the plans, this work shall also consist of markings by painting the surface, or portions thereof, of the island as specified.

**S-616.02--Material Requirements.** The materials used in this construction, in addition to conforming with the requirements of S-700 for materials specified and used, unless otherwise stipulated, shall conform to the following:

**S-616.02.1--Concrete.** The materials used in the manufacture of concrete shall conform to the requirements for the class of concrete specified as set out in S-804, as shown on the plans and in the proposal, or as otherwise indicated in the contract. Unless otherwise specified, Class "C" concrete shall be used.

**S-616.02.2--Joint Filler.** Joint filler shall be of the type specified on the plans and shall conform to the requirements as set forth in S-707 for the particular type specified. Unless otherwise specified, the filler shall be 1/2 inch premolded filler in accordance with S-707.02.2.

**S-616.02.3--Hot Plant Mix Pavement.** Hot Plant Mix Pavement shall be in accordance with the applicable materials and construction requirements of S-401 and S-403.

### **CONSTRUCTION REQUIREMENTS**

**S-616.03--Equipment.** The equipment shall conform to the requirements of S-401 and S-804, as applicable, with the exception of approved modified placement, shaping, compacting and finishing equipment will be permitted. All small tools, such as edgers, floats, tamps, etc., shall be approved tools of such quality and quantity as to assure their adequacy in the performance of acceptable work. Approved equipment necessary and required, shall be on the project in good working condition before construction will be permitted to start.

**S-616.04--Preparation of Grade.** Grade preparation shall be performed in accordance with the applicable provisions and requirements of S-205. After shaping as required, the entire area shall be treated with a soil sterilant as follows:

- (a) Soil sterilant material shall be applied at the maximum rate recommended on the manufacturer's label for perennial weed control. Any granular or pelletized type soil sterilant that is approved by the Engineer may be used. The approved material shall be uniformly spread over the entire area immediately prior to placing the pavement.



- (b) The chemical compounds shall be delivered to the job in unbroken containers with the manufacturer's label thereon.
- (c) The Contractor shall be responsible for performing all precautions as shown on the label of the containers and shall be liable for any injury or damage caused from handling or using the material until acceptance of the project.
- (d) Furnishing and placement of soil sterilant shall be absorbed in the cost of the other bid items.

**S-616.05--Forms.** Forms will not ordinarily be required, however, as specified or necessary, forms and forming shall be in accordance with the requirements of S-608.05.

**S-616.06--Manufacturing and Placing Concrete.** The concrete used in the construction of island pavement shall be manufactured, proportioned and placed in accordance with the requirements of S-804 - Concrete Bridges and Structures, with the exception of approved modified methods of placement, shaping and compacting will be permitted. Concrete surfaces shall be given a Class 6 float finish.

Immediately after mixing, the concrete shall be deposited in a single layer on the moist grade to such depth that, after finishing, it shall be of the full thickness required. The edges, side, etc., shall be thoroughly spaded, and the surfaces tamped sufficiently to compact the concrete and bring mortar, for finishing, to the surface.

The surface of the finished concrete shall conform closely to the typical section indicated on the plans and shall be without any irregularities which would not permit complete surface drainage, including drainage over the adjacent curb as indicated.

The edges of the concrete at expansion joints shall be edged with an edger having a radius of 1/2 inch.

**S-616.07--Blank.**

**S-616.08--Expansion Joints.** Unless otherwise shown on the plans, expansion joints shall be formed of premolded joint filler of the specified thickness, and shall be placed at the locations indicated on the plans. All joint fillers shall be cut to full cross-section and shall extend to the full depth, width and length of the construction. Any expansion joint material extruding after the concrete is finished, shall be trimmed as directed.

In the event the locations are not shown on the plans, specified joints shall be placed between all edges of the island pavement and the surrounding curb or pavement.

**S-616.09--Protection and Curing.** After the concrete is completed, it shall be protected and cured in accordance with the requirements of S-804.03.17 or other approved method.

Conditions governing the placement of concrete and the requirements for the placement, protection and curing of concrete during cold or hot weather shall conform to the limitations, conditions and requirements of S-804.03.16.1 or S-804.03.16.2, as applicable.

**S-616.10--Manufacturing and Placing Asphalt Pavement.** The Hot Mix Asphalt Pavement used in construction of island pavement shall be manufactured and placed in accordance with the requirements of S-401 and S-403, except that approved modified methods of placement, shaping and compacting will be permitted. The pavement shall consist of the layers and types as shown on the plans.

The surface of the finished Hot Mix Asphalt Pavement shall conform closely to the typical section indicated on the plans and shall be without any irregularity which would not permit complete surface drainage, including drainage over the adjacent curb as indicated.

**S-616.11--Cleaning Up.** All surplus material shall be disposed of as directed, and the completed work and the site shall be left in a neat and presentable condition.

**S-616.12--Markings.** When shown on the plans, pavement markings on island pavement shall be constructed as detailed, or as directed by the Engineer, and shall conform to all provisions and requirements of the applicable section(s), including measurement and payment, for the particular markings included in the contract.

**S-616.13--Method of Measurement.** The area of the completed and accepted island pavement will be measured in square yards of the actual area so paved.

Excavation will not be measured for payment, it being understood that the cost thereof is included in the other items of work.

Pavement markings, if required, will be measured as provided in the applicable section(s) for such items.

**S-616.14--Basis of Payment.** This work, measured as provided in S-616.13, will be paid for at the contract unit price bid per square yard, which price shall be full compensation for all incidental excavation and disposal of surplus material; for all materials; for all construction as specified herein or otherwise provided in the contract for island pavement; for all forms and forming if necessary and for all equipment, tools, labor and incidentals necessary to complete the work.

Payment will be made under:

**S-616-A:** Concrete Island Pavement - per square yard

**S-616-B:** Hot Mix Asphalt Island Pavement - per square yard

**S-617.01--Description.** This work shall consist of furnishing and placing concrete markers in accordance with the plans and these specifications or as directed. The work also shall include the removal of right-of-way markers from their original locations and resetting at new locations as specified or established.

### **MATERIALS**

**S-617.02--Material Requirements.** The materials used in this construction shall conform to the requirements of S-706.04.

### **CONSTRUCTION REQUIREMENTS**

**S-617.03--Construction Requirements.** Markers shall be cast in accordance with the details shown on the plans, the requirements of S-706.04, and the requirements of this section.

Reinforcement shall conform to the details shown on the plans and the requirements of S-602.

All letters and other markings shall be as shown on the plans and shall be neatly imprinted in the markers. Where required on the plans, the markings shall be painted in a workmanlike manner with the type of paint specified.

The markers shall be set to the depth and in the position designated on the plans and established by the Engineer. They shall be set to within 1/4 inch of the lines indicated or established, 1/2 inch of the depth or elevation indicated or directed, and in a vertical position within a tolerance of 1/8 inch per foot. Backfilling shall be made with suitable material thoroughly tamped in six- inch layers. All surplus material shall be disposed of as directed and the site shall be left in a neat and presentable condition.

**S-617.04--Removal and Resetting.** Markers which are specified to be removed and reset shall be carefully removed and reset at the location indicated and established in accordance with the provisions and requirements of S-617.03.

The Contractor shall replace without additional compensation all markers broken or damaged due to his carelessness or negligence during the removal and resetting operation.

**COMPENSATION**

**S-617.05--Method of Measurement.** New and removed and reset right-of-way markers will be measured per each.

**S-617.06--Basis of Payment.** Right-of-way markers complete in place will be paid for at the contract unit price per each, which shall be full compensation for completing the work specified.

Payment will be made under:

**S-617-A:** Right-of-Way Markers (\_\_\_\_\_) - per each  
(Type)

**S-617-B:** Right-of-Way Markers Removed and Reset - per each

**S-618.01--Description.**

**S-618.01.1--General.** This work shall consist of maintaining two-way local traffic at all times, except as provided herein or in other contract documents. It shall consist of removing temporary structures, constructing and maintaining in good condition approach roadways and other facilities required for the maintenance of traffic and furnishing temporary materials therefor, unless otherwise indicated in the contract.

This work shall include furnishing, erecting, maintaining in good condition, and removing all required construction signs, barricades, and temporary traffic stripe.

**S-618.01.2--Traffic Control Plan.** This work shall also consist of complying with the contract requirements of the Temporary Traffic Control Plan. The purpose of the Temporary Traffic Control Plan is to maintain through and local traffic safely through construction zones. In addition to this section, the Plan includes: S-104.04, S-105.15, S-107.07, and S-107.10; special provisions modifying this section and supplements thereto; individual plan sheets applicable to the plan; and Part VI of the Manual on Uniform Traffic Control Devices (MUTCD), latest edition. These parts of the Plan are listed for the bidders' information and do not change provisions of the contract, listed or unlisted, unless so specifically stated.

Where the plans call for guardrail to be replaced or removed and reset, all material shall be on hand at the time of removal and the resetting will be accomplished as per subsection S-606.05.1.

The Contractor's Traffic Safety Officer's responsibility shall be maintenance of the effectiveness of the Temporary Traffic Control Plan. The Contractor's Traffic Safety Officer's duties shall include the following:

1. Understand the requirements of the MUTCD and contract provisions.
2. Be responsible for assuring compliance of the Contractor's maintenance and protection of traffic relative to the requirements of the contract provisions.
3. Be responsible for maintaining current documentation of deficiencies with respect to the Contractor's maintenance and protection of traffic operations.
4. Be responsible for maintaining documentation on how and when the deficiencies were corrected.

5. Hold Contractor's traffic safety meetings.
6. Be responsible for assuring that all deficiencies are corrected.
7. Be responsible for coordinating maintenance of traffic operations with the Engineer.
8. Be responsible for reviewing Contractor's equipment location storage and operation relative to traffic safety and operation as required by the contract provisions.
9. Be responsible for reviewing Contractor's material location storage and handling of materials relative to traffic safety and operations.
10. Be responsible for maintaining current documentation of deficiencies and corresponding corrections relative to equipment operation, equipment storage, and material handling and storage pertaining to traffic safety and operations.

The Contractor shall also provide a suitable traffic vehicle, adequately marked and equipped, for the use of the Traffic Safety Officer. The Engineer shall be furnished with the telephone numbers where the Contractor's Traffic Safety Officer and a substitute, authorized to act in his absence, may be reached at all times when not on the project. This in no way modifies the requirements of S-105.05 regarding the assignment and availability of the superintendent.

Within three weeks time the Contractor shall provide the Engineer with a copy of each accident report for those accidents occurring within the limits of the project. In the event no accident report is available, the Contractor and the Engineer shall jointly attempt to describe the accident from sources or information that may be available. The Engineer, or other appropriate personnel as required, will analyze these reports to determine if corrective action is needed.

In the event corrective action is indicated, the Contractor shall proceed immediately with same.

The Engineer will designate a responsible person at the project level to monitor the Contractor's compliance with the plan.

### MATERIALS

**S-618.02--Material Requirements.** Unless otherwise specified, the Contractor shall provide all materials for the construction and maintenance of detours required for the maintenance of traffic, except the Engineer may permit the Contractor to use excavation from the roadbed, or other designated sources, that is available at the time of construction of diversions without detriment to the work and provided the excavation is ultimately placed in its final position in the roadbed in an uncontaminated condition. No additional compensation will be made to the Contractor for the extra handling of the material.

Unless otherwise specified, the applicable material requirements set out in the S-700 series of sections or in other contract documents shall apply to all materials used in temporary traffic facilities. The Contractor shall select and use materials that with adequate maintenance or replacement will provide a satisfactory facility for the entire period the temporary facility is required.

### CONSTRUCTION REQUIREMENTS

#### **S-618.03--Construction Details.**

**S-618.03.1--General.** All diversions shall be constructed and maintained in such a manner that they will adequately carry the required traffic.

Requirements for temporary traffic facilities shown on the plans, or set forth in these specifications, shall be understood to be the minimum requirements anticipated. Actual traffic conditions may require work or devices in addition to those shown on the plans.

Traffic lanes shall be kept free of dust, and when deemed necessary they shall be sprinkled with water, or some other dust palliative shall be applied.

Unless otherwise specified, temporary structures and roads shall be sufficiently strong to safely carry the load permitted on the road under construction. Structures shall be provided with suitable curbs, rails, or other devices as required for the protection of traffic. Unless otherwise specified, walkways when required for pedestrians shall have a clear width of at least four feet and shall be protected from vehicular traffic in the manner specified or directed.

Unless otherwise specified, the Contractor shall remove all temporary diversions, satisfactorily dispose of all surplus materials, grade, finish, and dress the disturbed areas to the required section, and complete all work incidental thereto prior to final acceptance.



**S-618.03.2--Barricades, Signs, and Flaggers.** The Contractor shall construct, erect, and maintain in good order all barricades and danger and warning signs specified or ordered.

Flaggers shall be stationed at such points as may be deemed necessary. Movable construction signs shall be moved from sections as their use become inapplicable.

Such signs and all other signs and devices of a temporary nature shall be in accordance with the plans, and the MUTCD, as applicable.

**S-618.04--Widening, Overlays, and Seal Coats.** On widening or widening and overlaying projects, the Contractor shall limit the base widening, pavement removal, undercutting, and patching operations to the lengths that are deemed to be consistent with backfilling and traffic handling requirements.

Pavement edge excavated for widening shall be protected with drums, cones, vertical panels or barricades until the trench is filled and compacted.

On the traffic lane adjacent to the lane being paved, opposing traffic may be alternately routed over the single lane in such a manner as to provide safe movement of the traffic with minimum delay. In such case, flaggers will be required and, when deemed necessary, an approved pilot vehicle with sign meeting the requirements of the plans and the current edition of the Manual on Uniform Traffic Control Devices (MUTCD), shall be provided and operated to control the speed and sequence of movement of the traffic.

A pavement edge that traffic is expected to cross in changing lanes should have an elevation difference of no greater than 1 1/2 inches. There should be adequate signs to warn the traveling public of lane drop-off.

All failed areas that have been removed and all trenches shall be filled and compacted to the elevation of the existing pavement before work is discontinued for the day. In emergencies, the Engineer may permit the use of approved temporary materials for backfill, provided the temporary materials will be adequate to facilitate normal safe movement of traffic. Separate measurement for payment will not be made for the furnishing, placing, maintaining, removing, and disposing of such temporary materials.

Except under the following conditions, no portion of the roadway which is intended to be used for maintenance of traffic shall be blocked after work hours. In exceptional cases when all efforts have been made to restore the surface of the roadway and because of equipment failure or other uncontrollable causes complete restoration is not possible before work must be discontinued for that day, the Contractor shall provide adequate warning signals, barricades, flares, other appropriate devices, and flaggers, appropriately placed or stationed for the protection of the public. The Engineer may also require the use of a pilot vehicle as provided herein.

**S-618.05--Contractor's Responsibility.** The Contractor shall be responsible for protection against loss or damage from any cause to all temporary structures (including approaches), and shall maintain them in a satisfactory condition until their use is no longer required. If a temporary structure, or approaches, is damaged due to high water or other reasons, it shall be replaced by the Contractor without extra compensation, except that for temporary structure and approaches constructed of materials and to the grades and sections indicated on the plans and in accordance with the applicable construction requirements of the contract and adequately maintained, consideration will be given under the conditions and provisions of S-107.17.

The Contractor shall maintain the surface of the existing facility and connections thereto on which he is required to maintain traffic. Such maintenance shall be in accordance with the provisions of S-104.04 and S-105.14 and other applicable requirements and shall be subject to the provisions of S-105.15. All costs for such maintenance and surface repairs shall be included in the contract price bid for Maintenance of Traffic. Repair of structural failures in the pavement foundation, or a structure beneath the surface not resulting from the Contractor's failure to comply with the requirements or limitations of the contract, or from his operations, will be the responsibility of the County. The Board and State Aid Engineer may, however, at their discretion require the Contractor to make repairs and will pay for them at the contract unit prices for the items and quantities of work involved or as Extra Work.

### **COMPENSATION**

**S-618.06--Method of Measurement.** This work will be measured as a unit (lump sum) quantity consisting of continuous maintenance and protective services. The percentages of the contract lump sum price allowed on the monthly estimate will be determined by the percentage of the combined total monetary value of all bid items earned during the current (same) estimate period.

In the event the Engineer determines that actual field and traffic conditions require fixed-in-place signs in addition to those shown on the plans, they shall be furnished, erected, and maintained, and measurement of these signs will be made by the square foot.

**S-618.07--Basis of Payment.** Maintenance of traffic will be paid for at the contract lump sum price which will also include compensation for complying with the requirements of the Traffic Control Plan.

For contracts not containing pay items for individual traffic control devices, additional construction signs ordered by the Engineer will be paid for at the fixed contract unit price indicated in the proposal.

These prices shall be full compensation for completing the work specified.

Payment will be made under:

**S-618-A:** Maintenance of Traffic - per lump sum

**S-618-B:** Additional Construction Signs - per square foot

**S-619.01--Description.** This work shall consist of furnishing materials and applying reflectorized 40 mil thick hot spray paint pavement markings in reasonably close conformity with these specifications and the details shown on the plans or established.

### MATERIALS

**S-619.02--Materials.** Paint shall be the color specified and shall meet the applicable requirements of S-710. The materials shall be a mixture of resins and other materials meeting EPA requirements for essentially non-volatile paint compound for traffic markings. Glass beads shall meet the requirements of S-710.03.5 and S-710.03.6.

Temporary raised pavement markers shall meet the requirements of this section and S-720.02.

### CONSTRUCTION REQUIREMENTS

**S-619.03--Equipment.** The equipment used to install hot applied paint material shall provide continuous uniform heating to temperatures exceeding 400°F, mixing and agitation of the material. Conveying parts of the equipment between the main material reservoir and the line dispensing device shall prevent accumulation and clogging. All parts of the equipment which come in contact with the material shall be constructed for easy accessibility and exposure for cleaning and maintenance. The equipment shall operate so that all mixing and conveying parts including the line dispensing device, maintains the material at the plastic temperature.

Glass beads applied to the surface of the completed marking shall be applied by an automatic bead dispenser attached to the marking machine so that the beads are dispensed closely behind the installed marking. The glass bead dispenser shall be equipped with an automatic cut-off control synchronized with the cut-off of the paint material.

All painting equipment and operations shall be under the control of an experienced technician thoroughly familiar with the equipment, materials, and marking layouts.

**S-619.04--Preparation of Surface.** All areas to be painted shall be thoroughly cleaned. Cleaning may be done by hand brooms, rotary brooms, air blast, scrapers, or whatever combination of equipment is necessary to clean the pavement thoroughly without damage to the surface. Before edge striping, particular care shall be taken to remove all vegetation, loose soil, and the like from the area to be painted. Should other methods fail, the surface shall be wetted with a water jet and scrubbed as necessary to dislodge all foreign material.

After washing, the surface shall be allowed to dry thoroughly, and all films of dried mud apparent after surface drying shall be removed before application of paint. Painting shall follow as closely as practicable after the surface has been cleaned and dried, but no paint shall be applied until the surface has been inspected and permission given to proceed. The cost for preparing the surface shall be included in the unit prices bid for the marking items.

The paint material shall be readily renewable by placing an overlay of new material directly over old markings of the same material. Such new material shall bond itself to the old markings in such a manner that no splitting or separation takes place. The contractor shall remove all existing material that might cause premature failure of the new material.

Upon request, the Engineer will establish control points for markings, by type and color, at necessary intervals not to exceed six hundred (600) feet. The Contractor shall preserve and apply markings in conformity with these control points, if established.

**S-619.05--Application.** The paint material shall be installed in a molten state by the spray method at a minimum temperature of 350°F and a maximum temperature of 425°F. Scorching or discoloration of material shall be cause for rejection by the Engineer. The machinery shall be constructed so that all mixing and conveying parts, up to and including the spray gun maintain the material in the molten state.

Paint pavement marking materials shall not be applied by the spray method when air and pavement surface temperatures are below 40°F or when the surface of the pavement contains any evidence of moisture.

The paint material shall be applied at a thickness of not less than 40 mils, but in no case shall it exceed a thickness of 50 mils.

The Contractor shall place the paint markings with adequate drop-on glass beads in accordance with requirements, uniformly applied to assure adequate nighttime reflectivity. It shall be the Contractor's responsibility to use a compatible combination of paint material and beads to preclude the surface beads from sinking deeply into the paint.

The length and width of lines shall be within a tolerance of plus or minus three inches and plus or minus 1/8 inch, respectively. For skip markings, the length of intervals shall not exceed the line length tolerance. Markings applied at less than minimum material rates, deviating from true alignment by more than one inch in fifty (50) feet, exceeding stipulated length and width tolerances, and showing light spots, faulty distribution of beads, smears, tracking due to traffic or other deficiencies or irregularities shall be removed and replaced. Removal methods shall be in accordance with S-619.08.

**S-619.06--Detail Traffic Stripe.** Detail traffic stripe shall be those short stripes, exclusive of lane and edge striping, at exit and entrance ramps, turnouts, turn bays, and other locations indicated on the plans. When shown on the plans or directed by the Engineer, detail stripe of the color, width, and length shall be placed in accordance with the provisions and requirements of this section.

**S-619.07--Legend.** Legend shall be applied by the use of templates cut to the dimensions shown on the plans, or by other methods approved by the Engineer which will provide a clean cut, uniform, and workmanlike appearance. All other requirements for legend shall be in accordance with the applicable materials and construction requirements of this section.

Legend which fails to have a uniform, satisfactory appearance either by day or by night shall be corrected by the Contractor or removed and replaced without additional cost to the Project.

**S-619.08--Temporary Traffic Striping.** When shown on the plans or directed by the Engineer, temporary stripe of the color(s) specified shall be placed in accordance with the provisions and requirements of this section. The length of each stripe of skip striping shall be at least four (4) feet with stripes of the same length and with skips of uniform length of forty (40) feet center to center of stripes.

After it has served its purpose and when so ordered by the Engineer, temporary stripe shall be removed by carefully controlled blast cleaning, approved grinding equipment, or other approved methods in such a manner that the surface to which the stripe was applied will not be unnecessarily damaged.

Unless otherwise specified, pressure sensitive, reflective adhesive tape meeting the requirements of S-720.05 for Type 2 may be used in lieu of temporary painted stripe. The Contractor shall replace portions of tape as necessary, and shall remove all temporary markings when specified or directed.

When noted on the plans temporary raised pavement markers shall be installed as per manufacturers recommendation or as directed by the Engineer. The temporary raised markers shall be flexible reflective tabs placed at forty (40) foot intervals on the centerline of the roadway. The markers shall be installed in a manner that reflective faces of the marker are perpendicular to a line parallel to roadway centerline.

If, in the opinion of the Engineer, the temporary raised markers require removing after permanent striping has been accomplished, they shall be removed in such a manner that the pavement surface will not be unnecessarily damaged.

**S-619.09--Acceptance:**

- (a) **Paint** - The manufacturer shall furnish the Engineer three (3) copies of certified test report(s) showing results of all required test(s) and certification(s) that the material meets the specifications. Prior to beginning striping a test section shall be performed on a prepared surface to determine if the specified thickness is obtained. During the striping operation the Engineer shall measure and record the thickness of stripe at random selected areas and record to insure adequate rate of application.
- (b) **Glass Beads** - The manufacturer shall furnish the Engineer three (3) copies of certified test report(s) showing results of all required test(s) and certification(s) that the material meets the specifications. The Engineer shall document acceptance as per S.O.P. No. SA-II-3-5.

**COMPENSATION**

**S-619.10--Method of Measurement.** Traffic Stripe will be measured horizontally by the mile or by the linear foot. The length used to measure centerline and edge stripes will be the horizontal length computed along the stationed control line. In the case of skip lines, the measurements will include skip intervals as well as painted sections.

Detail traffic stripe will be measured by the linear foot from end-to-end of individual stripes. Measurement will be made along the surface of each stripe and will include skip intervals where specified. A normal stripe is 4 to 6 inches wide, as indicated in the plans. Wide stripes will be converted to equivalent lengths of the normal stripes.

Legend will be measured by the square foot. Pay areas of individual components of legend will usually be shown on the plans.

When shown as a pay item, temporary traffic stripe completed and removed in accordance with the requirements of the contract will be measured by the linear foot from end-to-end of individual stripes. Measurement will be made along the surface of each stripe and will include skip intervals where skips are specified.

**S-619.11--Basis of Payment.** Traffic stripe will be paid for at the contract unit price per mile or by the linear foot as indicated in the proposal.

Detail traffic stripe will be paid for at the contract unit price per linear foot.

Legend will be paid for at the contract unit price per square foot.

Temporary traffic stripe will be paid for at the contract unit price per linear foot.

The prices thus paid shall be full compensation for completing the work specified.

When temporary raised markers are shown on the plans there shall be no separate pay item for this portion of work. The contractor shall include the material and labor for installation of these markers in the Maintenance of Traffic Pay Item S-618-A.

Payment will be made under:

<b>S-619-A:</b>	_____ “ Wide Traffic Stripe (Skip White)	- per mile
<b>S-619-AB:</b>	_____ “ Wide Traffic Stripe (Skip White) (Type III Drop On Glass Beads)	- per mile
<b>S-619-B:</b>	_____ “ Wide Traffic Stripe (Skip Yellow)	- per mile
<b>S-619-BB:</b>	_____ “ Wide Traffic Stripe (Skip Yellow) (Type III Drop On Glass Beads)	- per mile
<b>S-619-C:</b>	_____ “ Wide Traffic Stripe (Continuous White)	- per linear foot
<b>S-619-CB:</b>	_____ “ Wide Traffic Stripe (Continuous White) (Type III Drop On Glass Beads)	- per linear foot
<b>S-619-D:</b>	_____ “ Wide Traffic Stripe (Continuous Yellow)	- per linear foot
<b>S-619-DB:</b>	_____ “ Wide Traffic Stripe (Continuous Yellow) (Type III Drop On Glass Beads)	- per linear foot
<b>S-619-E:</b>	_____ “ Wide Temporary Traffic Stripe	- per linear foot
<b>S-619-EB:</b>	_____ “ Wide Temporary Traffic Stripe (Type III Drop On Glass Beads)	- per linear foot
<b>S-619-F:</b>	Detail Traffic Stripe	- per linear foot
<b>S-619-FB:</b>	Detail Traffic Stripe (Type III Drop On Glass Beads)	- per linear foot
<b>S-619-G:</b>	Legend	- per square foot
<b>S-619-GB:</b>	Legend (Type III Drop On Glass Beads)	- per square foot



**S-620.01--Description.** This work shall consist of furnishing materials and installing cold plastic pavement markings in reasonably close conformity with the plans and these specifications.

### **MATERIALS**

**S-620.02--Materials.** Cold plastic marking material shall meet the requirements of S-720.04.

### **CONSTRUCTION REQUIREMENTS**

**S-620.03--Equipment.** The material manufacturer shall furnish a mechanical applicator for the application of sixteen (16) inch wide film. The mechanical applicator shall be provided on location at the time designated and for the duration of the application period. The material manufacturer shall provide technical assistance for operation and maintenance of the mechanical applicator at the discretion of the Engineer.

**S-620.04--General Construction Requirements.** The free-air temperature shall be at least 60°F. The pavement surface shall be dry and clean. All dirt, loose particles of pavement, and other foreign material shall be removed prior to application of the pavement marking material. All longitudinal stripes shall be mechanically applied. Detail stripe and legend may be applied manually. Only butt splices without overlay will be permitted for multiple piece and line type markings. Except for legend, the specified width of the markings shall be made in a single tape application. Where possible, the markings shall be placed adjacent to rather than on longitudinal construction joints in the pavement. Placement tolerance will be those set out in S-619.05. Markings not meeting these tolerances shall be removed and replaced at the Contractor's expense.

**S-620.05--Application.** Both mechanical and manual application shall be in accordance with the manufacturer's instructions. A liquid contact cement shall be used at the rate recommended by the manufacturer for detail stripe and legend symbols. Liquid contact cement shall not be used elsewhere unless specified by the manufacturer. When liquid contact cement is used, the newly placed markings shall be protected from traffic for the period of time recommended by the manufacturer of the cement.

### **COMPENSATION**

**S-620.06--Method of Measurement.** Cold plastic pavement markings completed in accordance with the plans and specifications will be measured by the mile or by the linear foot. In the case of skip lines, the measurement will include skips. The length used to measure centerline and edge stripes will be the horizontal length computed along the stationed control line.

Detail traffic stripe will be measured by the linear foot from end-to-end of individual stripes. Measurements will be made along the surface of each stripe and will include skip intervals where skips are specified. A normal stripe is 4 to 6 inches wide, as indicated in the plans. Wide stripes will be converted to equivalent lengths of the normal stripes.

Legend will be measured by the square foot. Pay areas of individual components will usually be shown on the plans.

**S-620.07--Basis of Payment.** Accepted quantities of cold plastic pavement markings will be paid for at the contract unit prices. These prices shall be full compensation for completing the work specified.

Payment will be made under:

<b>S-620-A:</b>	_____ “ Wide Cold Plastic Traffic Stripe (Skip White)	- per mile
<b>S-620-B:</b>	_____ “ Wide Cold Plastic Traffic Stripe (Continuous White)	- per mile
<b>S-620-C:</b>	_____ “ Wide Cold Plastic Edge Stripe (Continuous White)	- per mile
<b>S-620-D:</b>	_____ “ Wide Cold Plastic Traffic Stripe (Skip Yellow)	- per mile
<b>S-620-E-1:</b>	_____ “ Wide Cold Plastic Traffic Stripe (Continuous Yellow)	- per linear foot
<b>S-620-E-1:</b>	_____ “ Wide Cold Plastic Traffic Stripe (Continuous Yellow)	- per mile
<b>S-620-F:</b>	_____ “ Wide Cold Plastic Edge Stripe (Continuous Yellow)	- per mile
<b>S-620-G:</b>	Cold Plastic Detail Stripe (White) (4" Equivalent Length)	- per linear foot
<b>S-620-H:</b>	Cold Plastic Detail Stripe (Yellow) (4" Equivalent Length)	- per linear foot
<b>S-620-L-1:</b>	Cold Plastic Legend (White)	- per linear foot
<b>S-620-L-2:</b>	Cold Plastic Legend (White)	- per square foot

**S-621.01--Description.** This work consists of furnishing materials and placing thermoplastic pavement markings in reasonably close conformity with these specifications and the details shown on the plans or established.

### **MATERIALS**

**S-621.02--Materials.** Thermoplastic material shall meet the requirements of S-720.03, except an alkyd resin shall be used in the formulation when used in construction of stop lines, crosswalks, and legends.

Glass beads shall meet the requirements of S-720.01.

### **CONSTRUCTION REQUIREMENTS**

**S-621.03--Equipment.** Equipment for hot application shall be of sufficient size and stability to insure smooth, uniform, properly aligned markings of the thickness specified.

The application equipment shall be capable of automatic placement of intermittent and continuous line patterns in single or double line applications simultaneously. The intermittent timer mechanism shall provide a variable ratio of materials applied and variable cycle length such that accurate placement of new patterns, or replacement of existing patterns can be achieved.

The equipment shall also be capable of applying the top dressing of glass beads in a manner which will firmly embed them into the surface of the thermoplastic material for at least one half the diameter of the larger gradation sizes of the beads. The dispensing equipment shall be equipped with an automatic cut-off control for the application of the beads which is synchronized with the cut-off of the thermoplastic material.

**S-621.04--Construction Details.** Application of thermoplastic material shall be made only in periods of dry weather and when the temperature of the pavement surface is at least 55°F. The pavement shall be surface dry, to the satisfaction of the Engineer, before application will be permitted. The temperature of the thermoplastic material shall be between 400°F and 450°F.

Upon request, the Engineer will establish the control points for markings at necessary intervals not to exceed 600 feet on tangents and more often on curves. All additional work necessary to establish intermediate control points shall be performed by the Contractor. On curves, unsightly variations from the normal curvature will not be permitted unless specifically shown on the plans or ordered by the Engineer.

Immediately before application, the areas to receive markings shall be cleaned thoroughly in accordance with S-619.04. On areas of pavement cured with compound, the membrane shall be removed completely by "shot" blasting, sand blasting or other approved method.

Unless otherwise directed by the Engineer, traffic stripes that are coincidental with the thermoplastic stripe shall be removed prior to placement of the thermoplastic material, except that short-term paint stripe may be left in place when satisfactorily placed in the proper location. Any short-term stripe not covered shall be removed. Payment for removal of stripe, except temporary and short-term stripe, will be made under S-202.

When thermoplastic material is to be applied to portland cement concrete pavements or bridge surfaces, a binder-sealer of the type and amount recommended by the manufacturer of the thermoplastic material shall be applied prior to placement of the thermoplastic material. On other pavement surfaces, a binder-sealer shall be applied under those conditions recommended by the manufacturer of the thermoplastic material.

The thickness of the thermoplastic material, when measured above the surface plane of the pavement, shall be within tolerance of the specified thickness. Unless otherwise specified in the plans or contract documents, the thickness shall be 60 mils for edge lines, 90 mils for centerlines, lane lines, barrier lines and detail stripe including gore markings, and 120 mils for crosswalks, stop lines, and railroad, word and symbol markings. The measured thickness at the center of the line shall be no less than the specified thickness with the edge of the line not thinner than 75% of the specified center thickness and will be checked at intervals of one mile or less as directed by the Engineer.

Any thermoplastic traffic marking less than the required thickness shall be corrected by overlaying with an additional application of thermoplastic material. Any such required overlay will be no less than 30 mils. Although a tolerance of 25 percent from center to edge is allowed, a consistent underrun of any amount in thickness will not be acceptable.

All newly applied thermoplastic material shall be protected from traffic until the material is sufficiently dry so as not to sustain damage from vehicle tires. Any material so damaged, marred or picked up by traffic shall be repaired, and the thermoplastic material tracked onto the pavement shall be removed.

The tolerance for placing thermoplastic stripe shall be the same as required for paint (reference S-619.05).





**S-627.01--Description.** This work consists of furnishing and placing pavement markers of the types, colors, shapes, and dimensions specified and in reasonably close conformity with the location lines, and details shown on the plans or as directed by the Engineer.

### **MATERIALS**

**S-627.02--Materials.** Pavement and jiggle markers of the types specified shall conform to the applicable requirements of S-720.06 and shall be listed on MDOT's "Approved Sources of Materials".

Types B through G High Performance reflective markers shall be listed on MDOT's "Approved Source of Materials" for high performance raised pavement markers.

The bituminous adhesive for pavement markers shall meet the requirements of S-720.06.7.

### **CONSTRUCTION REQUIREMENTS**

#### **S-627.03--Construction Requirements.**

**S-627.03.1--General.** Unless waived by the State Aid Engineer on the basis of known performance qualifications, the Contractor or approved subcontractor shall certify to the Engineer that sufficient experience has been acquired to have become proficient in the placement of the required markers, or the Contractor or approved subcontractor shall require the manufacturer of the markers to have a qualified technical representative on or immediately available to the project during the application of the markers to assist the Contractor's personnel in the proper application of the adhesive and markers and to render technical assistance to the Engineer as may be deemed desirable.

Any such waiver shall be subject to the conditions set forth in the waiver.

**S-627.03.2--Construction Details.** The markers shall be installed when the relative humidity of the air is 80% or less, the pavement surface is dry and the temperature of the pavement surface is no less than 50°F. Other pavement marking materials, such as thermoplastic, cold plastic and paint, shall be placed prior to installation of markers.

The portion of the highway surface to which the marker is to be bonded shall be cleaned so as to be free of dirt, curing compound, grease, oil, moisture, loose or unsound layers, paint and any other material which would adversely affect the bond of the adhesive.

The bituminous adhesive shall be melted and heated in either thermostatically controlled double boiler type units utilizing heat transfer oil or thermostatically controlled electric heating pots. Direct flame melting units shall not be used. The melter/applicator unit shall be suited for both melting and pumping application through heated applicator hoses.

The adhesive shall be heated to between 375°F and 425°F and applied directly to the pavement surface from the melter/applicator by either pumping or pouring. It is important that application temperature be maintained between 375°F and 425°F and lower temperatures may result in decreased adhesion while higher temperatures may damage the adhesive.

The adhesive should be applied in a puddle approximately two-thirds to three-fourths the diameter of the marker. Markers should be applied to the adhesive within 10 seconds to assure bonding. The marker shall be placed in position by applying downward pressure until the marker is firmly seated with the required adhesive thickness and squeeze out. Excessive adhesive squeeze out shall be removed from the pavement and adhesive on the exposed surfaces of the markers shall be immediately removed. Soft rags moistened with mineral spirits conforming to Federal Specification TT-T-291 or kerosene may be used if necessary, to remove adhesive from exposed faces of pavement markers. No other solvent shall be used.

All markers shall be installed in a uniform line, with controls established by the Engineer. The Engineer will establish controls for each line of markers by setting control points at not less than approximately 600-foot intervals on tangents and 50-foot intervals on curves. All additional work necessary to establish intermediate control points and individual marker points shall be performed by the Contractor, including smoothing out minor irregularities in any line established by the Engineer. On curves, the line of markers on lane lines and edge lines shall follow the normal curvature of the curve and placement on chords or other variations from the normal curvature will not be permitted, unless specifically shown on the plans or ordered by the Engineer.

Reflective markers shall be installed in such a manner that the reflective face of the marker is perpendicular to a line parallel to the roadway centerline. No markers shall be installed over longitudinal or transverse joints of the pavement surface.

The marker shall be protected against impact until the adhesive has hardened. The Engineer shall be the judge as to the minimum time necessary to cure the adhesive for sufficient set to bear traffic. The adhesive may be reheated and reused. However, the pot life at application temperatures shall not be exceeded.

Clean out of equipment and tanks may be performed using petroleum solvents such as diesel fuel or similar materials. CAUTION: Be sure that all heating is off before cleaning operations are begun. All solvent must be removed from the equipment tanks and lines before the next use of the melter.



**S-627.04--Method of Measurement:** Each type of raised markers acceptably placed will be measured as determined form actual count in place.

**S-627.05--Basis of Payment:** Raised pavement markers will be paid for at the respective contract unit price per each, which shall be full compensation for completing the work.

Payment will be made under:

<b><u>S-627-A:</u></b>	Type A, Non-Reflective White Raised Jiggle Markers _____ (Class)	- per each
<b><u>S-627-AY:</u></b>	Type AY, Non-Reflective Yellow Raised Jiggle Markers _____ (Class)	- per each
<b><u>S-627-B:</u></b>	Two-Way Clear Reflective Raised Markers	- per each
<b><u>S-627-C:</u></b>	Red-Clear Reflective Raised Markers	- per each
<b><u>S-627-D:</u></b>	Two-Way Yellow Reflective Raised Markers	- per each
<b><u>S-627-E:</u></b>	One-Way Clear Reflective Raised Markers	- per each
<b><u>S-627-F:</u></b>	One-Way Yellow Reflective Raised Markers	- per each
<b><u>S-627-G:</u></b>	Yellow-Clear Reflective Raised Markers	- per each
<b><u>S-627-H:</u></b>	Chip Seal Clear Reflective Raised Markers	- per each
<b><u>S-627-I:</u></b>	Chip Seal Yellow Reflective Raised Markers	- per each
<b><u>S-627-J:</u></b>	Two-Way Clear Reflective High Performance Raised Markers	- per each
<b><u>S-627-K:</u></b>	Red-Clear Reflective High Performance Raised Markers	- per each
<b><u>S-627-L:</u></b>	Two-Way Yellow Reflective High Performance Raised Markers	- per each
<b><u>S-627-M:</u></b>	One-Way Clear Reflective High Performance Raised Markers	- per each
<b><u>S-627-N:</u></b>	One-Way Yellow Reflective High Performance Raised Markers	- per each
<b><u>S-627-O:</u></b>	Yellow-Clear Reflective High Performance Raised Markers	- per each

**Sections S-628 and S-629 – Blank**

**S-630.01--Description.** This work shall consist of furnishing and installing delineators, reflectorized traffic signs and markers and reflectorized warning and railroad crossing signs together with accessories and posts of the designated materials, sizes, shapes, weights and designs in reasonably close conformity with the requirements shown on the plans and set out in these specifications.

In general, the work and materials shall meet the requirements of the "Manual on Uniform Traffic Control Devices for Streets and Highways," or latest revision thereof, except as modified by these specifications or as shown on the plans.

Sign fabrication shall be in a properly equipped plant which shall show evidence of successful experience in fabrication and erection of quality reflectorized highway warning signs.

### **MATERIALS**

**S-630.02--Materials.** All materials or equipment shall be of new stock and shall be the product of a reputable manufacturer. Completed equipment and materials shall be guaranteed to be free from defects in materials and workmanship for a reasonable period of time after erection.

Materials furnished or used shall conform with the following and shall be subject to inspection and testing as required by the Engineer:

**S-630.02.1--Steel Posts.** Steel posts for small signs shall be furnished in accordance with S-721.02.3.

Posts for railroad cross buck signs shall be 4" x 6" treated timber. The minimum length shall be fourteen (14) feet when erected.

**S-630.02.2--Fabrication of Aluminum Extrusions and Sheets.** The fabrication of aluminum extrusions and sheets shall generally conform to the requirements of S-721.03.

**S-630.02.3--Concrete** shall conform to S-601.

**S-630.02.4--Colors and Paints** shall match the colors specified by "The Manual on Uniform Traffic Control Devices for Streets and Highways," and S-721.05.

**S-630.02.5--Reflective Sheeting.** The reflective sheeting materials used in the manufacture of standard Highway and Marking signs shall conform to S-721.06 for brightness, adhesiveness, color, film, surface and durability.

**S-630.02.6--Delineators and Prismatic Markers.** See S-721.07 for design requirements, fabrication and finishing of the frames, as well as the tests and durability qualifications.

**S-630.02.7--Timber Posts for All Signs.** See S-721.09 for requirements of size and treatment with pentachlorophenol-petroleum solution.

**S-630.02.8--Preparation of Sheet Aluminum or Steel for the Application of Reflective Sheeting or Painting.** See S-721.

**S-630.02.9--Silk Screen Method of Reflectorization.** See S-721.

**S-630.02.10--Packing, Storing and Shipping Highway Warning Signs.** See S-721.

### **CONSTRUCTION REQUIREMENTS**

#### **S-630.03--Construction Methods.**

**S-630.03.1--Construction Stakes.** The Engineer or his authorized personnel will furnish and set a construction stake at each site clearly indicating thereon the respective sign for that site and will furnish the Contractor with all the required information relating to lines and grades. The Contractor will be required to check all leading dimensions and clearances measured from such stakes and thereafter become responsible for orientation, elevation, offset and level of all signs so erected.

**S-630.03.2--Sign Positioning.** The glossy surface on sign face may produce specular reflection. Signs shall be positioned to eliminate or minimize specular reflection.

**S-630.03.3--Ground-Mounted Highway Signs.** Signs shall be erected so that the sign face is truly vertical and at 93° away from center of the travel lane which the sign serves and the direction of travel unless otherwise directed by the Engineer. Where lanes divide or on curves, sign faces shall be oriented so as to be most effective both day and night and to avoid the possibility of specular reflection.

**S-630.03.4--Horizontal Clearance and Height.** Signs erected at the side of the road shall be placed as shown on the plans.

Where raised edge curbs, guard rails, or paved shoulders are present the sign should ordinarily be placed with its nearest edge two feet outside of such curb or guard rail.

**S-630.03.5--Posts.** When steel posts are used they shall be ten (10) feet minimum length. Steel posts may be driven in place to a minimum depth of two and one-half (2 1/2) feet with the ground plate at least six inches below the ground elevation.

When treated timber posts are used they shall be set in holes dug to full depth and to sufficient diameter to allow proper tamping and compaction of the backfill. The backfill shall be made with the most suitable material available and shall be tamped until the posts are firm and rigid in a truly vertical position. Treated timber posts shall be a minimum length of ten (10) feet and set to a minimum depth of two and one-half (2 1/2) feet into the ground.

**S-630.03.6--Erection of Signs.** Erection of signs shall be done in a neat and workmanlike manner. After installation of signs is complete they shall be inspected at night by the Engineer. If specular reflection is apparent on any sign, its positioning shall be adjusted by the Contractor to eliminate this condition.

**S-630.03.7--Erection of Delineators.** The location of each type of delineators shall be as shown on the plans or as directed by the Engineer. They shall be placed two feet outside the shoulder edge, except in curbed sections where they will be placed two feet outside the face of the curb. The post shall be driven and a driving cap used to protect the post. Posts shall be installed so that the delineator units will be at the elevations specified on the plans or established by the Engineer and they shall be vertical and reasonably true to line and grade. The delineator shall be attached to the post as shown on the plans.

**S-630.03.8--Removal of In-Place Signs, Markers and Posts.** The Contractor shall salvage existing signs, markers and posts and stockpile at the locations shown on the plans or as directed by the Engineer. Signs and markers shall be removed from posts and be stacked edgewise with paper separators between units. Posts shall be pulled without being bent, and stockpiled off the ground. All handling, hauling and storing shall be such as to avoid damage. The work shall be incidental to items of the contract and separate payment will not be allowed.

**S-630.04--Placement and Erection of Railroad Warning and Crossing Signs.** This work shall conform to the requirements as shown on the plans and the requirements of American Association of Railroad specifications.

The cross buck signs shall be mounted on the right hand side of the roadway on each approach to the crossing not more than fifteen (15) feet from the center line of the nearest track. It shall not be less than six feet, or more than twelve (12) feet from the edge of the pavement, or less than two feet outside of the paved shoulder or curb. The height shall be approximately nine feet above the level of the highway to the center of the cross buck.

The Railroad Advanced Warning signs shall be yellow disk, 36 inches in diameter, carrying a 90-degree cross buck X and letter RR in black, reflectorized with reflective sheeting and mounted on a wooden post in advance of every railroad crossing. Advance warning signs are required whether the crossing is protected with cross bucks, signals or flaggers. Exception to the installation of advanced warning signs are (1) a minor siding or spur which is infrequently used and which is guarded by a member of the train crew when in use, or (2) in business districts where crossings are fully protected and physical conditions are such that even a partially effective display of the sign is impossible. In areas where low train speeds are prevalent, the advanced warning sign may be placed a minimum of 100 feet from the crossing. Street or road intersections within 100 feet of a crossing may also require additional signs to warn approaching traffic from each intersection road or street.

The Contractor will be required to check all controlling dimensions and clearances mentioned above and become responsible for orientation, elevation, offset and level of all signs erected.

**S-630.05--Final Cleaning Up.** The Contractor will be required to remove all rejected and unused materials and debris from the right-of-way. He shall restore shoulders and slopes to their original condition. Excess excavation shall be disposed of off the right-of-way at the Contractor's own expense unless otherwise directed by the Engineer. Before final inspection the Contractor shall perform such touching up of paint finishes, cleaning of exposed sign and support surfaces and other cleaning up as may be necessary to ensure the effectiveness and neat appearance of the work.

### **COMPENSATION**

**S-630.06--Method of Measurement.** Reflectorized signs of the size, color and markings as prescribed in the "Manual on Uniform Traffic Control Devices for Streets and Highways," or revision thereof, delineators and hazard markers will be paid for by the unit installed including posts, parts, fastenings, fittings, labor, tools and incidentals necessary to complete the work.

Reflectorized cross buck warning signs and Advanced Railroad Warning signs of the size, color and markings as prescribed in the "Manual on Uniform Traffic Control Devices for Streets and Highways," or revision thereof, will be paid for per each, installed, including posts, parts, fastenings, fittings, labor, tools, excavation for the footings, painting, and incidentals necessary to complete the work.

Concrete, if required, for post stabilization will not be measured and paid for separately, but shall be included in the contract unit price bid per sign.

Excavation for posts shall not be measured for separate payment, but shall be included in the unit price bid per sign.

Paint, painting and reflectorization will not be measured for separate payment, but shall be included in unit price bid per sign.

**S-630.07--Basis of Payment.** Reflectorized Traffic Warning Signs and Markings, Delineators, Object Markers and Regulatory Signs will be paid for at the contract unit price bid per sign installed and accepted; which price shall be full compensation for all materials, equipment, tools, labor and incidentals necessary to complete the work.

Reflectorized advanced warning signs and Railroad Crossing signs will be paid for at the contract unit price bid per sign, complete in place, measured as provided above, which price shall be full compensation for each sign completely installed, for the materials, equipment, tools, labor and incidentals necessary to complete the work.

Payment will be made under:

<b>S-630-A:</b>	Reflectorized Traffic Warning Sign (Encapsulated Lens)	- per each
<b>S-630-B:</b>	Reflectorized Traffic Regulatory Sign (Encapsulated Lens)	- per each
<b>S-630-C:</b>	Reflectorized Traffic Object Marker (Encapsulated Lens) (Type ____)	- per each
<b>S-630-D:</b>	Reflectorized Traffic Delineator Sign (Encapsulated Lens)	- per each
<b>S-630-E:</b>	Reflectorized Railroad Crossing (Cross buck) Sign (Encapsulated Lens)	- per each
<b>S-630-F:</b>	Reflectorized Advanced Warning Sign (Encapsulated Lens)	- per each
<b>S-630-G:</b>	Reflectorized Traffic Warning Sign with Supp. Plate (Encapsulated Lens)	- per each
<b>S-630-H:</b>	Reflectorized Traffic Regulatory Sign with Supp. Plate (Encapsulated Lens)	- per each

**S-631.01--Description.** This work shall consist of furnishing and placing a flowable fill material. Uses include, but are not limited to, placement under existing bridges, around or within box culverts or pipe culverts, or at other locations shown on the plans.

**S-631.02--Materials.** All materials shall meet the requirements of the following Specifications:

Fine Aggregate *	.....	See Note Below
Portland Cement	.....	S-701.01 and S-701.02
Fly Ash	.....	S-714.05
Air Entraining Admixtures**	.....	S-713.02
Water	.....	S-714.01

\* Note -Fine Aggregate gradation shall be fine enough to stay in suspension in the mortar to the extent required for proper flow and shall conform to the following grading:

<u>Sieve Size</u>	<u>% Passing</u>
½ inch	100
No. 200	< 1

\*\* Note - High air generators shall be used. These generators increase the flowable fill's air content to 15 - 35% while reducing settlement and bleed water. Only approved air generators will be allowed to be used to obtain the required air content.

**S-631.02.1--Mix Design.** Flowable fill is a mixture of Portland cement, fly ash, fine aggregate, air entraining admixture and/or high air generators and water. Flowable fill contains a low cementitious content for reduced strength development.

The consistency of the fresh mixture shall be that of a thin slurry. It shall be tested by filling an open-ended three inch diameter by six inches high cylinder to the top, with the mixture and the cylinder immediately pulled straight up. The correct consistency of the mixture will produce an approximate eight-inch diameter circular-type spread with no segregation. Adjustments of the proportions of fine aggregate and/or water may be made to achieve proper solid suspension and optimum flowability, however the theoretical yield shall be maintained at one cubic yard for the given batch weights.

The Contractor shall submit mix designs for flowable fill to the Engineer to be verified by the MDOT Materials Division or other State Aid approved Lab. The following table is a guide for proportioning flowable fill.

Material	Amount
Cement Type I	75 - 150 lbs/yd <sup>3</sup>
Fly Ash	150 - 600 lbs/yd <sup>3</sup>
Fine Aggregate	*
Water	**
Air†	15 - 35%
28 Day Compressive Strength†	Minimum 125 psi
Unit Weight, Wet †	90 - 110 lbs/ft <sup>3</sup>

\* Fine Aggregate proportioned to yield one cubic yard as verified by unit weight.

\*\* Mix designs shall produce a consistency that will result in a flowable self-leveling product at time of placement.

† The requirements for percent air, compressive strength and unit weight are for Laboratory designs only and are not intended for jobsite acceptance requirements. An accepted air-generating admixture shall be used when no settlement is required.

**S-631.02.2--Acceptance of Mix.** The acceptance of the mix design shall be based on primary properties which include: compressive strength, air content, hardening time, flowability, yield and settlement. This test data shall be submitted with the mix design. Continued use and acceptance, which will be based on the performance of the mix placed, will be at the discretion of the Engineer.

**S-631.02.3--Manufacturing.** Flowable fill will be manufactured at plants in accordance with S-804.

**S-631.03--Construction Requirements.** Prior to placing flowable fill, each end of the structure shall be plugged leaving an opening at each end no larger than necessary to accommodate the filling equipment. Flowable fill shall be discharged from the mixer by any reasonable means into the area to be filled. Unless otherwise approved by the Engineer, filling will begin on the downstream end of the structure and continue until no further material will enter the structure. The flowable fill will then be continued from the upstream end of the structure.



**S-631.04--Method of Measurement.** Flowable fill will be measured by the cubic yard which will be determined by calculating yield. The yield will be calculated by dividing the actual batch weights of each load by the unit weight of the mix, which will be determined by testing the first load placed on each production day.

**S-631.05--Basis of Payment.** Flowable fill will be paid for at the contract unit price per cubic yard which shall be full compensation for furnishing and placing the material, for drilling and filling holes if necessary, furnishing all labor, equipment, tools and materials necessary to complete the work.

Payment will be made under:

**S-631-A:** Flowable Fill - per cubic yard

**S-632.01--Description.** Roadbed Reclamation shall consist of pulverizing and mixing the existing asphalt pavement together with base, subbase, and/or subgrade materials with portland cement and water to produce a uniform mixture meeting density requirements to serve as a base course for the pavement. Preliminary pulverization of the asphalt pavement and preliminary mixing of the existing asphalt pavement together with base, subbase, and/or subgrade materials are permitted.

The Contractor shall mix the cement-stabilized base only when the weather permits the course to be finished without interruption in the time specified.

The Contractor shall begin mixing only when the air temperature is above 40°F in the shade, and rising.

Seasonal limitations for Roadbed Reclamation shall coincide with seasonal limitations for cement stabilization.

**S-632.02--Materials.** Portland Cement used shall conform to the requirements of S-701.01.

**S-632.03--Construction Requirements.**

(a) Equipment.

The pulverizing and mixing shall be done with one or more machines that produce the required degree of pulverization and uniformity.

Other pieces of equipment that may be required are a motorized grader, cement spreading unit, water truck, and compaction equipment.

The Engineer will not approve specific equipment for this work prior to its use on the project but will require the Contractor to use equipment that will produce a base course mixture meeting the requirements of these specifications.

(b) Length of Roadbed Allowed to Be Processed.

Except by written permission of the Engineer, the length of roadbed pulverized at any time shall not exceed the length that can be completely pulverized, mixed, compacted, cured and protected against damage by normal anticipated traffic in the same working day.

(c) Spreading of Cement.

The Engineer may require pulverization and shaping of the pulverized roadbed materials to produce the required section before the placement of the cement. Otherwise, cement may be spread either prior to the pulverization and mixing or after an initial pulverization.

The amount of cement required to be placed will be shown on the plans or as determined from soil tests. Spreading of the cement shall be done with a spreader truck or other approved means to insure a uniform distribution. Pneumatic application through a slotted pipe will not be permitted. The amount of cement placed shall not vary more than 5 % of the total amount required.

Cement shall be applied in a limited area so that all the operations can be continuous and completed in daylight hours, within 3 hours of the application of the cement.

Only the equipment that is used in spreading and mixing will be allowed to pass over the spread cement before it is mixed into the existing materials. Cement that has been displaced shall be replaced before mixing is started.

(d) Pulverizing and Mixing.

The width and depth of the required pulverizing and mixing will be shown on plans. The depth of pulverizing shall be controlled to insure that the finished thickness will be within the required tolerance limits. Pulverizing and mixing may be accomplished in one or more passes subject to meeting the pulverization and uniformity requirements of these specifications. Spreading of cement prior to the pulverization and mixing is allowed and encouraged provided the pulverization and mixing equipment do not create excessive dusting or displacement of the cement that would alter the uniform distribution of cement throughout the section.

The pulverizing and mixing shall breakup the existing roadbed to the extent that 98% to 100% by weight, exclusive of gravel or stone particles, passes a 2 inch sieve and a minimum of 95% passes a 1.5 inch sieve. The moisture content shall be maintained at a point that allows compaction to the required density.

(e) Mixing Cement with Pulverized Materials.

The contractor may perform initial dry mixing of the cement with the existing roadbed materials or may inject moisture into the mixing chamber of the mixing/pulverizing equipment during the first mixing. Water shall not be added by a spray bar from a water truck directly onto the unmixed cement spread. The cement shall be thoroughly mixed with the pulverized roadbed materials to provide a uniform distribution of the cement throughout the mixture.

(f) Mixing Water with Cement and Pulverized Materials.

If the contractor does not inject moisture into the mixing chamber of the pulverizer/mixer during the first mixing, the pulverizer/mixer shall then be used to mix water into the mixture of cement and pulverized roadbed materials. The mixing shall be completed in one or more continuous pass(es) of the mixing unit. The mixture of the water, cement and pulverized roadbed materials shall be within the tolerance limits of optimum moisture content and shall be in a condition suitable for immediate compaction without further mixing or grading.

For mixing units that inject moisture into the mixing chamber, a gage or gages shall be provided to allow the continuous monitoring of the amount of water that is applied. When the mixer will handle only a part of the roadbed width, the successive increments shall be of such length that the full width of treated material may be promptly mixed, compacted and finished, with not more than 30 minutes between mixing adjacent lanes. The asphalt and cement mix shall not remain undisturbed after mixing and before compaction for more than 30 minutes.

When the uncompacted mixture is made too wet by the addition of too much water, or by rain, and the moisture content exceeds the specified tolerance for compaction, the entire affected section may be remixed at the Contractor's expense in an effort to dry the mixture through aeration.

(g) Compaction and Finishing.

The pulverizing, mixing and compaction shall be a continuous operation. The compaction of the mixture of water, cement and roadbed materials shall begin within 30 minutes after the final mixing. The mixture shall be compacted to a minimum of 95% of the field laboratory maximum density. Compaction and finishing shall be completed within a period of one hour after the final mixing.

Sheep foot rollers, pad foot rollers, or similar equipment, shall be used for the compaction.

After the mixture has been compacted, the surface shall be shaped to the required lines, grades, and cross sections to within the required tolerances. During the shaping, light scarifying may be necessary to prevent the formation of compaction planes. Broom dragging or clipping of the surface may be required as a part of the process of shaping the surface during compaction. The surface material shall be maintained at the specified moisture content during finishing operations. The final compaction and finishing operations may be varied, if necessary, to produce a smooth, dense surface free of surface compaction planes, cracks, ridges or loose material.

(h) Testing, Tolerance, and Deficiency Correction.

The thickness of the base will be checked by the Engineer at intervals of 3000 feet, or more often if necessary. A tolerance of +/- 8 % from the plan designated thickness at any point will be permitted. The average thickness of the base completed in one day shall not vary more than 6 % from the thickness shown on the plans.

The finished surface shall not vary more than 1/2 inch from the design grade. The Contractor shall provide a straight edge and template and employees to use them to check the surface as directed by the Engineer.

High spots in the finished surface may be corrected by motor grader or planer without additional compensation, provided the resulting thickness is within the tolerances listed above. Other areas outside allowable tolerance or deficient in density will be rejected and shall be reconstructed by the Contractor at his own expense, including necessary cement. The amount of cement to be used in reconstruction will be determined by the Engineer.

Measurements will be made promptly upon completion of compaction and finishing in order that correction may be made before the mixture has hardened.

(i) Surface Moisture.

The finished surface shall be kept moist until the curing seal, surface treatment or next pavement course is applied.

(j) Curing.

A bituminous curing seal shall be applied over the entire surface of the Roadbed Reclamation. The surface shall be protected from drying prior to application of the curing seal. The rate of application shall be from 0.20 to 0.35 gallons per square yard. The completed Roadbed Reclamation shall be cured for a minimum of one week after final compaction has been completed unless the next pavement course is applied prior to that time.

(k) Opening to Traffic.

Traffic shall be placed on the roadway as directed by the Engineer.

**S-632.04--Method of Measurement.** Roadbed Reclamation will be measured in units of square yards. The length will be measured along the surface of the pavement. The width shall be the width specified on the plans or in writing by the Engineer.

**S-632.05--Basis of Payment.** The contract unit price for Roadbed Reclamation shall be the full price for furnishing all materials (cement, water), curing seal, equipment, tools, labor, and incidentals necessary to complete the work.

Payment will be made under:

**S-632-A:** Roadbed Reclamation - per square yard.

**Sections S-633 thru S-699 - Blank.**

<b><u>Section</u></b>	<b><u>Page</u></b>
S-700 - MATERIALS AND TESTS	7-1
S-701 - HYDRAULIC CEMENT	7-8
S-702 - BITUMINOUS MATERIALS	7-10
S-703 - AGGREGATES	7-20
S-704 - AGGREGATE FOR DRAINAGE	7-39
S-705 - STONE BLANKET PROTECTION AND FILTER BLANKET MATERIALS	7-40
S-706 - MASONRY UNITS	7-42
S-707 - JOINT MATERIALS	7-44
S-708 - NON-METAL STRUCTURES AND CATTLEPASSES	7-52
S-709 - METAL PIPE	7-62
S-710 - PAINT	7-66
S-711 - REINFORCEMENT AND WIRE ROPE	7-78
S-712 - GUARDRAIL	7-84
S-713 - CONCRETE CURING MATERIALS AND ADMIXTURES	7-85
S-714 - MISCELLANEOUS MATERIALS	7-87
S-715 - ROADSIDE DEVELOPMENT MATERIALS	7-107
S-716 - MISCELLANEOUS METALS	7-116
S-717 - STRUCTURAL STEEL	7-119
S-718 - TIMBER AND DIMENSION LUMBER	7-130
S-719 - PILES	7-136
S-720 - PAVEMENT MARKING MATERIALS	7-138
S-721 - MATERIALS FOR SIGNING	7-153
S-722 - GEOGRIDS	7-164
S-723 - thru S-799 - Blank	7-165





**S-700.01--General.** Materials will be inspected and sampled in accordance with the Office of State Aid Road Construction current S.O.P. pertaining to inspecting and sampling.

Unless otherwise provided, all materials furnished which are to remain in place after final acceptance shall be new and unused before incorporation into the work, except that crushed reclaimed concrete pavement meeting the requirements of S-703, as amended, may be used to produce aggregate for all hot mix asphalt pavements. When allowed by the specifications, Recycled Asphalt Pavement (RAP) may be used in the manufacture of hot mix asphalt pavements. Other recycled products approved for use by MDOT State Materials Engineer may be incorporated in the work.

The Contractor shall maintain sufficient approved materials on hand so that delays to the work will not result from the necessary sampling, testing, and evaluation of test results.

Domestic steel, iron and wire products including prestressing cable and strand shall be furnished for incorporation in the work. All manufacturing processes, including application of a coating, for these materials must occur domestically. However, pig iron and processed, pelletized, and reduced iron ore manufactured outside of the United States may be used in the domestic manufacturing process for steel and/or iron products. For the purpose of this specification, the activity of coating is considered a manufacturing process. The material being applied as a coating is not covered under Buy America. Coating includes all processes which protect or enhance the value of the material to which the coating is applied, such as epoxy coating, galvanizing, painting, etc.

Domestic shall be understood to mean all States of the United States, District of Columbia, Puerto Rico, American Samoa, Guam, the Virgin Islands and any other place subject to the jurisdiction of the United States.

In the case of coatings for the above referenced domestic steel, iron and wire products, it shall be the Contractor's responsibility to forward to the MDOT State Materials Engineer a certified statement from those having applied a coating to these materials that the application of the coating occurred domestically.

It shall be Contractor's responsibility to forward to the MDOT State Materials Engineer such acceptable certification from the manufacturer, or at the election of the MDOT State Materials Engineer, such certification may be acceptable directly from a manufacturer annually, or more often, when requested by the MDOT State Materials Engineer.

**S-700.02--Glossary of Terms and Definitions.**

Aggregate - Inert material such as sand, gravel, lightweight aggregates, broken stone, slag, or combinations thereof.

Argillaceous - Containing or consisting of clay.

Asphaltic Cement - A product of the refining of crude oil to form a residue which is used usually without the addition of more than a small quantity of flux or any liquifying agent of a higher volatile material than the residue itself.

Calcareous Material - A material containing more than 50 percent calcium type material.

Cementitious Material - Portland cement, or blend of portland cement and pozzolan material used as the bonding agent in portland cement concrete. Cementitious shall mean "as having cementing properties".

Clay - The fraction of a soil finer than 0.005 mm that is more or less plastic when wet.

Compaction - The process of obtaining the density of a soil or material.

Contemplated Mean Value (CMV) - The CMV is the desirable average or target value that is designated between extreme limits that are tolerable in materials or workmanship.

Crusher Run - The product of a crushing plant that has not been rescreened or separated into various sizes.

Cutback Asphalt - An asphaltic material obtained from the refining of petroleum by adding to or fluxing the residue from distillation with volatile petroleum fractions to produce a uniform mixture which is capable of becoming quite fluid at relatively low temperatures.

Fineness Modulus - An empirical factor obtained by adding the total percentages of aggregate retained on the Nos. 100, 50, 30, 16, 8, 4, 3/8", 3/4", 1 1/2", and 3" sieves and dividing the sum by 100.

Frame - The part of the work or materials for which the same quality characteristics are specified, such as a base course, an aggregate stockpile, a hot bituminous pavement course, etc.

Gravel - The granular, pebbly material (usually retained on a No. 8 sieve) resulting from the natural disintegration of rock.

Increment - The smallest unit(s) set aside for the sampling and testing process.

Liquid Limit (LL) - The water content, expressed in percentage by weight of the oven dried soil, at which the soil passes from a plastic to a liquid state when subjected to a standard method of determining liquid limit of soils.

Loess - Wind-blown, yellowish-brown loam having little or no stratification.

Lot - A subdivision of a frame, representing a designated quantity of work or materials, and is the unit of such work or materials which will be accepted or rejected.

Mechanical Analysis - The determination of the size and grading of soil particles by standard tests.

Optimum Moisture - The moisture content necessary to obtain the standard density of a soil.

Overburden - Refers to soil or similar material directly above a deposit of rock, sand, gravel, or select material.

Pea Gravel - That portion of uncrushed gravel passing a 3/8 inch sieve and retained on a No. 8 sieve.

Plastic Limit (PL) - The water content, expressed in percentage by weight of the oven-dried soil, at which a soil passes from a solid or semi-solid state to a plastic state when subjected to a standard method of determining plastic limit of soils.

Plasticity Index (PI) - The range of water content through which the soil remains in a plastic condition. This term is the numerical difference between the liquid limit and plastic limit and is a measure of cohesion.

Portland Cement Concrete - A concrete mixture composed of cementitious materials, water, fine aggregate, coarse aggregate and possibly admixture(s).

Sample - The portion taken from a lot and considered to represent the whole or a designated portion of the lot. It may consist of one or more increments or a fractional part of one or more combined increments.

Sand - A fine granular material resulting from the natural or mechanical disintegration of rock. Depending on its use, material may be classed as sand if it passes the 3/8 inch, No. 4 or No. 10 sieve.

Sand Clay - A mixture of sand and clay often found blended so that their opposite qualities tend to maintain a condition of stability under varying moisture contents.

Screenings - Broken rock, limestone, slag, or other material, including the dust, of a size that will pass a 1/2 inch sieve.

Selected Material - Material from approved sources, for use in subbases, bases, or for other specified use.

Shale - A fissile rock formed by the consolidation of clay, mud, or silt having a finely stratified or laminated structure.

Shrinkage Limit (SL) - The maximum calculated water content of a soil at which a reduction in water content will not cause a decrease in the volume of the soil mass.

Sieves - Sieves for testing purposes conforming to the requirements of the standard Specifications for Sieves for Testing Purposes of the AASHTO Designation: M 92.

Silt - The finer particles of organic or rock substance, ranging in size from 0.05 mm to 0.005 mm.

Slag - The nonmetallic product thrown off from molten ore or metal or other processes and used as fine or coarse aggregate.

Soil - A natural aggregate of mineral grains, with or without organic constituents, that can be separated by gentle mechanical means such as agitation in water.

Spall - A relatively small piece or fragment broken from rock, concrete, or other material.

Specific Gravity - The ratio of the weight of a volume of some substance to the weight of an equal volume of substance, usually water, taken as a standard or unit.

Standard Density (Standard Compaction) - The maximum dry unit weight in pounds per cubic foot obtained by the compactive effort exerted under the applicable test designation as provided in S-700.03.

Sublot - The smallest unit(s) set aside from a lot for the sampling and testing process.

Test Portion - The actual quantity of material tested--may be in some instances the whole of the sample or in other instances only a quartered or other portion of the sample.

Test Result - The value of the specified characteristic obtained from testing a single test portion.

Test Value - The value determined as being the test result when only one test is required to satisfy a specified condition, or the average of the test results on two or more test portions of a lot, or a designated portion thereof.

Volume Change (VC) - The decrease in volume of the soil mass when the water content is reduced from a given percentage to the shrinkage limit.

Water-Cement Ratio - The ratio of the weight of water used, including free moisture in the aggregate, to the weight of cementitious material.

Other Definitions - Other applicable definitions as prepared by the Special Committee on Nomenclature and adopted by AASHTO.

**S-700.03--Sampling and Testing.** Sampling and testing for acceptance and control of materials may be performed at any time prior to incorporation in the work. Sampling and testing for control and acceptance of a work item will be performed progressively as sections of the work item are being constructed or completed, as applicable.

Unless otherwise designated, all tests will be made in accordance with applicable standard methods of AASHTO, ASTM, Federal Specifications, or approved Mississippi Test Methods (MT\_\_\_\_\_) in effect on the date of advertisement for bids. Note: It is contemplated that certain methods of testing will be developed by MDOT. These will generally consist of minor revisions of AASHTO or ASTM Methods and will be designed to more nearly fit local conditions. Such methods are designated MT\_\_\_\_\_. As such methods are developed, approved, and issued, they will be used as standards in field testing or in the Central Laboratory or other approved Laboratory, as designated in the method, on projects advertised subsequent to their approval and issuance.

Material requiring specified tests used by a plant for producing composite material(s) or product(s) to be used in the work will be tested and approved by the Engineer. If such materials, composite materials, or products are stored separately for the exclusive use in the work, the cost of testing will be borne by the Project. If such materials, composite materials or products are not stored separately for the exclusive use in the work, the cost of testing shall be borne as set out in the Office of State Aid Road Construction's issued SOP in effect at the time bids are received.

**S-700.04--Determination of Conformity.** The determination of conformity with each required measurable characteristic under the intent of S-105.03 will be made in accordance with the following:

All test values or test results used to determine compliance will be rounded off to the nearest decimal point as expressed in the specification for the particular characteristic under consideration. Fractions beyond the point of rounding amounting to less than 0.50 will be dropped. Similar fractions amounting to more than 0.50 will be rounded off by increasing the last digit within the rounding. Similar fractions, amounting to even 0.50 will be rounded toward the specifications by dropping, or by increasing the last digit within the rounding, as applicable.

The various frames of materials or work will be divided into lots as specified in the contract or conforming to the Office of State Aid Road Construction's S.O.P. for frequency of sampling and testing.

In the case of borderline quality products or a demonstrated trend toward borderline quality products, the Engineer will require the Contractor to improve the quality of the materials or work to more nearly conform to the specifications and may require a suspension of the operations which have resulted in the borderline product or the trend toward borderline quality until such corrective measures have been taken as deemed necessary to produce the contemplated quality products.

All increments of tests for determination of acceptance will be taken by random sampling. However, during or as a result of visual inspection, the Engineer will take increments for testing for progress checks or spot checks at any time and place he may deem necessary to determine weak spots or other progress information. The results of any such progress or spot checks may be used to determine whether or not additional work or corrective action is considered necessary prior to acceptance testing.

Minimum and maximum requirements in these specifications are set out on the basis that the desirable average test value of the materials or work is appreciably above the minimum requirement or appreciably below the maximum requirement established.

**S-700.05--Material Certifications and Certified Test Reports.** All certifications and certified test reports shall meet the requirements set forth herein except certification requirements for cement and asphalt are set out separately in State Aid's SOP.

**S-700.05.1--Certifications.** All certifications shall:

- (a) Have letterhead of the manufacturer, producer, supplier, or fabricator.
- (b) Include the project number.
- (c) Itemized list of materials covered by the certification.
- (d) Contain a material conformance statement which certifies that the materials conform to the specific specification requirements. Example: I/We hereby certify the materials listed herein conform to the requirements of S-714.13 of the Mississippi Standard Specifications for State Aid Road and Bridge Construction.
- (e) Certification for all iron, steel and steel wire products must also include a certified statement by the manufacturer that all of the manufacturing processes, excluding those for pig iron and processed, pelletized, and reduced iron ore used in the manufacture of said steel and/or iron products, have occurred domestically.
- (f) Signature of a responsible company official.

**S-700.05.2--Certified Test Reports.** All certified test reports shall:

- (a) Have letterhead of the manufacturer, producer, supplier, fabricator, or laboratory.
- (b) Include name and description of material, lot, batch or heat number, etc., as applicable.
- (d) Show results of each required test, and state that the test was run according to the test method specified.
- (e) Test reports for all iron, steel and steel wire products must also include a certified statement by the manufacturer that all of the manufacturing processes, excluding those for pig iron and processed, pelletized, and reduced iron ore used in the manufacture of said steel and/or iron products, have occurred domestically.
- (f) Signature of the responsible laboratory official.

**S-701.00--General.** The following requirements shall be applicable to hydraulic cement:

1. Different brands of cement, or the same brand of cement from different mills, shall not be mixed or used alternately in any one class of construction or structure, without written permission from the Engineer; except that this requirement will not be applicable to cement treatment of design soils, subbases, or bases.
2. The Contractor shall provide suitable means for storing and protecting the cement against dampness. Cement, which for any reason, has become partially set or which contains lumps of caked cement will be rejected. Cement salvaged from discarded or used bags shall not be used.
3. The temperature of bulk cement shall not be greater than 165°F at the time of incorporation in the mix.
4. One barrel (bbl) of cement shall be equivalent to four bags or 376 pounds.
5. Low-alkali cement, with maximum sodium and potassium oxides of 0.6%, will be furnished in all types.
6. Except when otherwise specified or prohibited, either Type I, IP or II portland cement shall be used. Type III portland cement may be used in the production of precast or prestressed concrete members.
7. Acceptance of hydraulic cement will be based on the certification program and job control sampling and testing as established in the SOP.
8. Retests of cement may be made for soundness and expansion within 28 days of test failure and, if the cement passes, it may be accepted. Cement shall not be rejected due to failure to meet the fineness requirements if upon retests after drying at 100°C for one hour, it meets such requirements.



**S-701.01--Portland Cement.** Portland cement shall conform to the requirements of AASHTO Designation: M 85 with the following exceptions:

The maximum values for the fineness of the grind as set out in Table 2 of AASHTO M 85 are hereby waived for Type I cement to be used in the production of prestressed concrete members.

When Portland cement concrete or cement for soil stabilization is exposed to moderate or severe soluble sulfates, or to seawater, cement types and/or replacement of cement by Class F fly ash (FA) or ground granulated blast furnace slag (GGBFS) shall be as follows:

**Cementitious Materials for Soluble Sulfate Conditions**

Sulfate Exposure	Water-soluble sulfate (SO <sub>4</sub> ) in soil, % by mass	Sulfate (SO <sub>4</sub> ) in water, ppm	Cementitious material required
Moderate and Seawater	0.10 - 0.20	150 - 1500	Type II cement or Type I cement with 25% Class F, FA or 50% GGBFS replacement
Severe	0.20 - 2.00	1500 - 10,000	Type II cement with 25% Class F, FA or 50% GGBFS replacement

**S-701.02--Masonry Cement.** Masonry cement shall conform to S-701.00 and ASTM Designation: C 91.

**S-701.03--Blended Hydraulic Cement.** When permitted in the contract, blended hydraulic cement shall conform to S-701.00 and AASHTO Designation: M 240.

**S-702.00--Bituminous Materials.**

**S-702.01--General.** Bituminous materials shall include asphalt cement, cutback asphalt, or emulsified asphalt and shall meet the requirements of the applicable specifications. The material furnished for any item in any one contract shall be of one brand, type, and grade, unless special permission is obtained otherwise. Materials furnished shall exhibit uniform characteristics.

When more than one grade of material is called for under any item, the Contractor, with the approval of the Engineer, will select the grade to be used.

All sampling and reporting of bituminous materials shall be performed as set out in the Office of State Aid Road Construction SOP. All testing will be performed in accordance with applicable AASHTO methods unless specifically modified by a Mississippi Test Method (MT\_\_\_\_\_).

Bituminous material shall not be heated during the process of its manufacture, or during construction, to a temperature which causes injury as evidenced by the formation of carbonized particles.

Bituminous material wasted through careless handling or material that has been rendered unfit for use by overheating or long continued heating will not be paid for, and the use of such unfit material will not be permitted.

**S-702.02--Measurement.** Volumetric measurement of bituminous materials by the U.S. gallon will be based upon a temperature of 60°F. Corrections to this temperature for asphalt cement, cutback asphalts and emulsified asphalt will be made in accordance with the Temperature Correction Tables set out in the State Aid Standard Operating Procedures.

For purposes of measurement, a U.S. gallon shall be a volume of 231 cubic inches.

When bituminous material is to be paid for by the gallon, the distributor tank(s) or storage tank(s), as applicable, to be used for measurement shall be calibrated by an agency and in a manner approved by MDOT. A calibration chart, showing the dimensions and volume per inch of depth, and a measuring gauge, calibrated in inches, shall be furnished the Engineer. Each tank shall have an identifying serial number on a steel plate welded or riveted to the tank. In the event the Contractor does not have such calibration chart, previously made by an approved agency, MDOT will, upon request, perform the calibration and furnish required charts; however, the Contractor will be fully responsible for any delays occasioned by such calibration by MDOT.

The measurements shall be taken when the bituminous material is of a uniform temperature and free of air bubbles. In no case shall the total number of gallons of bituminous material allowed for a tank exceed the capacity of the tank as rated by either the U. S. Interstate Commerce Commission, the State Tax Commission, or MDOT.

**S-702.03--Heating Bituminous Material.** Tanks for heating and storage of bituminous materials shall be capable of heating the material to the specified temperature under effective and positive control at all times. The heating system shall provide uniform heating for the entire contents of the tank. The circulating system shall be adequate to insure proper and continuous circulation of the material during the entire operating period. Suitable means shall be provided, either by steamjacketing or other insulation, for maintaining the specified temperature of the bituminous material in the lines, meters, weigh buckets, spray bars, and other containers or flow lines.

Thermometers of approved type and adequate range, calibrated in 5°F increments, shall be located at points readily visible. These thermometers shall be kept clean and in good condition at all times.

Where storage tanks are required, the capacity shall be sufficient for at least one day's run.

The heating of bituminous materials shall be rigidly maintained at the "lowest workable temperature."

**S-702.04--Sampling.** Sampling of bituminous materials will be in accordance with AASHTO Designation: T 40.

**S-702.05--Petroleum Asphalt Cement.** Asphalt cement shall be homogeneous, free of water and shall not foam when heated to a temperature of 175°C.

Except for use in hot mix asphalt, asphalt cement of the grade specified shall conform to the requirements of S-702.12, Table I or II.

Bituminous material conforming to AASHTO Designation: M 320, Grade PG 58-28 may be used in lieu of petroleum asphalt cement, Grade AC-10.

The bituminous material used in all types of hot mix asphalt shall conform to AASHTO Designation: M 320, Performance Grade PG 67-22, as modified in the table below, except when otherwise specified or when polymer modified hot mix asphalt is specified.

Specifications For Performance Graded Asphalt Binders Not Addressed By  
AASHTO M 320

	Grade	
Property	PG 67-22	
	Specification	Test Method, ASSHTO
Original Binder		
Flash Point Temperature	minimum 230°C	T 48
Rotational Viscosity	maximum 3 Pa•s @ 135°C	T 316
Dynamic Shear, G*/sin d	minimum 1.00 kPa @ 67°C	T 315
Rolling Thin Film Oven Residue (AASHTO Designation: T 240)		
Mass Loss (RTFO)	maximum 1.00 %	T 240
Dynamic Shear, G*/ sin d	minimum 2.20 kPa @ 67°C	T 315
Pressure Aging Vessel Residue (AASHTO Designation: PP1)		
Dynamic Shear, G* sin d	maximum 5000 kPa @ 26.5°C	T 315
Creep Stiffness, S	maximum 300 MPa @ -12°C	T 313
m-value	minimum 0.300 @ -12°C	T 313

The bituminous material used in polymer modified hot mix asphalt shall conform to AASHTO Designation: M 320, Grade PG 76-22 or PG 82-22. Unless otherwise indicated in the contract, Grade PG 76-22 will be used in polymer modified hot mix asphalt.

Asphalt cement Grade PG 76-22 & PG 82-22 shall be the product resulting from the addition of a polymer modifier to a PG 67-22 or lower grade asphalt cement and not by some other refining technique. The polymer shall meet the requirements of S-702.08.3.

**S-702.06--Cutback Asphalts.** Cutback asphalt shall consist of a liquid asphalt produced by the fluxing of an asphaltic base with a suitable distillate. It shall be of uniform consistency, free of water, and shall show no separation or curdling prior to use; and shall conform to the following requirements.

**S-702.06.1--Rapid-Curing Cutback Asphalt.** AASHTO Designation: M 81.

**S-702.06.2--Medium-Curing Cutback Asphalt.** AASHTO Designation: M 82.

The standard naphtha solvent shall be used when the spot test is performed.

**S-702.07--Emulsified Asphalt.** Emulsified asphalt shall be homogeneous, showing no separation of asphalt, limits for settlement excepted, after thorough mixing, within 30 days after delivery.

Emulsified asphalts which have been subjected to freezing temperatures while in storage shall be retested and acceptance of the material shall be based on the results of such retest.

Emulsified asphalts, of the grade specified, shall conform to the following requirements:

**S-702.07.1--Emulsified Primes.** Emulsified Primes shall conform to the requirements of S-702.12, Table III.

**S-702.07.2--Anionic and Cationic.** Anionic and Cationic Emulsion shall conform to the requirements of AASHTO Designation: M 140 and AASHTO Designation: M 208, respectively, with the following exceptions.

Exception: The required tests on residue may be performed on residue obtained by evaporation at 325°F., three hours, 50 grams, after filtering through a No. 50 sieve; however, in the event of the failure of any test performed on this residue, the emulsion shall be distilled and the test repeated on the residue so obtained.

**S-702.07.3--Polymer Modified Cationic Emulsified Asphalt (CRS-2P).** Polymer Modified Cationic Emulsified Asphalt shall conform to the requirements of AASHTO Designation: M 316.

**S-702.08--Asphalt Additives.**

**S-702.08.1--Asphalt Antistrip Additives.** The antistrip additive shall meet the following properties:

1. The bituminous mixture (with antistrip additive) when tested in accordance with Mississippi Test Method MT-63, shall yield a minimum Tensile Strength Ratio (TSR) of 85 and must show an increase in indirect tensile strength for a water conditioned specimen; and by visual examination of the interior faces of the water conditioned specimen, the proportion of stripped aggregate particles shall not exceed five (5) percent.
2. The rate of application shall be determined for each job-mix formula during the mix design process using Mississippi Test Method MT-63.
3. A stripping test, MT-63, will be performed for each job-mix formula at the beginning of plant production and thereafter, no less than one test per two week's production. A minimum of one stripping test per day of production according to Mississippi Test Method MT-59 shall also be conducted. Should either the TSR (MT-63) or the boiling water (MT-59) stripping test fail, a new antistrip rate shall be established or other changes made immediately that will result in a mixture which conforms to the specifications; otherwise, production shall be suspended until corrections are made.

The antistrip additive shall not present any difficulties in mixing of the liquid asphalt with the particular aggregates proposed for use.

The liquid asphalt and antistrip agent mixture shall meet the viscosity requirements for the grade of liquid asphalt used in the paving mix.

**S-702.08.2--Silicone.** When specified or permitted, silicone with a viscosity of 1,000 centistokes at 77°F shall be added to the asphalt cement at the rate of one ounce per 5,000 gallons.

**S-702.08.3--Polymers.** The polymer shall be a Styrene Butadiene Styrene (SBS), a Styrene Butadiene Rubber (SBR) or an equal approved by the Engineer. The polymer shall be thoroughly blended with the asphalt cement at the refinery or terminal prior to shipment to the hot-mix plant. Producers of polymer modified asphalt cement must be listed on MDOT's Approved List of Suppliers of Polymer Modified Asphalt Cement. The producer of the polymer modified asphalt cement shall perform or have performed by an approved laboratory all tests contained in AASHTO Designation: M 320 on a lot basis. A lot shall consist of one (1) refinery or terminal storage tank not to exceed

225,000 gallons. The Producer shall furnish two copies of a certified test report (one copy for the Contractor and one copy for the Engineer) with each shipment. A third copy of the certified test report shall be mailed to the MDOT State Materials Engineer. The certified test report shall contain the following:

4. Test results showing complete conformance to AASHTO Designation: M 320.
5. Type and percentage of polymer added.
6. A statement certifying that the transport vehicle was inspected prior to loading and was found to be empty.
7. A statement certifying that the shipment conforms to Mississippi Department of Transportation specifications for the grade of polymer modified asphalt cement specified.
8. A copy of the temperature-viscosity curve attached to the certified test report.

Crumb rubber used as a polymer modifier shall meet the following additional requirements:

Crumb rubber shall be produced by ambient grinding methods. The rubber shall be sufficiently dry so as to be free flowing and to prevent foaming when mixed with asphalt cement. The rubber shall be free of contaminants including fabric, metal, minerals and other non-rubber substances. Up to four percent, by weight of rubber, of talc, such as magnesium silicate or calcium carbonate, may be added to prevent sticking and caking of the particles.

The crumb rubber shall be tested in accordance with AASHTO Designation: T 27 with the following exceptions: a 100-gram sample size and up to 25% dusting agent (talc). Rubber balls may also be used to aid in the sieving of finely ground rubber. The resulting rubber gradation shall meet the gradation limits shown herein.

#### **Gradations of Crumb Rubber**

##### **Type A**

<u>Sieve Size</u>	<u>% Passing</u>
10	--
20	--
30	--
40	100
60	98-100
80	90-100
100	70-90
200	35-60

The specific gravity of the rubber shall be  $1.15 \pm 0.05$  when tested in accordance with ASTM Designation: D 297, pycnometer method.

The moisture content shall be determined in accordance with AASHTO Designation: T 255, with the exception that the oven temperature shall be  $140 \pm 5^\circ\text{F}$  and the weight of the sample shall be 50 grams. The moisture content shall not exceed 0.75% by weight.

No more than 0.01% metal particles shall be detected when thoroughly passing a magnet through a 50-gram sample.

The chemical composition of the crumb rubber shall be determined in accordance with ASTM Designation: D 297 and shall meet the following requirements:

Acetone Extract .....	Maximum 25 percent
Rubber Hydrocarbon Content .....	40 to 55 percent
Ash Content .....	Maximum 10 percent
Carbon Black Content .....	20 to 40 percent
Natural Rubber .....	16 to 34 percent

Crumb rubber meeting these specifications shall be supplied in moisture resistant packaging such as either disposal bags or other appropriate bulk containers. Each container or bag of crumb rubber shall be labeled with the manufacturer's designation for the rubber and the specific type, maximum nominal size, weight and manufacturer's batch or lot designation.

The producer of the polymer modified asphalt cement shall furnish the MDOT State Materials Engineer one copy of the manufacturer's certified test results covering each shipment of crumb rubber. These reports shall indicate the results of tests required by this specification. The reports shall also include a certification that the material conforms with the specifications, and shall be identified by manufacturer's batch or lot number.

**S-702.09 and S-702.10--Blank.**

**S-702.11--Application Temperatures.** Bituminous materials for the several applications indicated in the specifications shall be applied within the temperature ranges shown in S-702.12, Table IV.



**S-702.12--Tables.**

**TABLE I  
SPECIFICATIONS FOR ASPHALT CEMENT (PETROLEUM)**

Test	*AC-5		AC-10		**AC-13		
	Min.	Max.	Min.	Max.	Min.	Max.	
Viscosity @ 140°F, poises	400	600	800	1200			
Viscosity @ 140°F, poises	175	--	240	--			
Penetration @ 32°F					25		
Penetration @ 77°F, 100g, 5 sec.	140	--	80	-	65	90	
Penetration @ 115°F						325	
Flash Point COC, °F	400	--	425	-	450	--	
Solubility in Trichloroethylene	99.0	--	99.0	-	99.0	--	
Tests on Residue from Thin- Film Oven Test:							
Viscosity, 140°F, poises	---	2250	-	4500			
Ductility, 77°F, 5 cm per min. cm.	100	-	100	-	75	--	
% Loss on Heating	---	1.0	---	0.5	-	0.5	
Specific Gravity @ 60°F/60°F					1.0		
Spot Test: Standard Naphtha Solvent		Negative for all Grades ***					
Softening Point, °F (R & B)					110		

- NOTES: \* When cut-back asphalt cement is to be produced as specified in S-702.06, this material shall be the base asphalt.
- \*\* This is an asphaltic material used primarily for sealing joints and cracks.
- \*\*\* If positive, the test must be rerun with a solution of 75% naphtha and 25% xylene.

**TABLE II**  
**SPECIFICATIONS FOR ASPHALT CEMENT (PETROLEUM) (Continued)**

Test	*AC-5		AC-10		**AC-13	
	Min.	Max.	Min.	Max.	Min.	Max.
Viscosity @ 140°F (60°C), poises	1600	2400	2400	3600	3200	--
Viscosity @ 275°F (135°C), C <sub>s</sub>	300	-	350	-	350	
Penetration @ 32°F (0°C)						--
Penetration @ 77°F (25°C) 100g, 5 sec.	60	--	50	-	40	--
Penetration @ 115°F (46°C)						
Flash Point COC, °F	450	--	450	-	450	--
Solubility in Trichloroethylene	99.0	--	99.0	-	99.0	--
Tests on Residue from Thin-Film Oven Test:						
Viscosity, 140°F (60°C), poises	---	9000	-	13500	-	18000
Ductility, 77°F (25°C), 5 cm / min., cm.	80	-	60	-	40	--
% Loss on Heating	---	0.5	---	0.5	-	0.5
Specific Gravity @ 60°F/60°F						
Spot Test: Standard Naphtha Solvent		Negative for all Grades *				
Softening Point, °F (R & B)						

NOTES: \* If positive, the test must be rerun with a solution of 75% naphtha and 25% xylene.

**TABLE III**  
**SPECIFICATION FOR EA-1 PRIME**

Test Requirements	Minimum	Maximum
Furol Viscosity @ 122°F	30	100
Water Content Xylene Distillation, %	3	8
<b>Test on Residue from Distillation</b>		
Ductility @ 77°F, cms.	40	
Solubility in Trichloroethylene, %	97.0	
Asphalt Cement, % of Total Primer	50.0	
Penetration @ 77°F, 100 g., 5 sec.	80	300

**SPECIFICATION FOR AE-P PRIME**

Test Requirements	Min.	Max.	AASHTO Test Method
25°C SFS Viscosity, sec.	10	50	T-59
5-Day Settlement, %	--	5	T-59
Total Distillate, % weight	--	55	T-59
Oil Distillate, % volume	--	12	T-59
Tests on Residue from Distillation: Distillation to 500°F (AASHTO T-59)			
60°C Float Test, sec.	20	--	T-50
Solubility in TCE, %	97.5	--	T-44

**TABLE IV**  
**WORKING TEMPERATURES FOR BITUMINOUS MATERIALS**

Bituminous Materials	Temperature, °F			
	Spraying		Mixing	
	Min.	Max.	Min.	Max.
Asphalt All Cements	275	350	225	350
Cutback Asphalts RC & MC				
30	80	150	60	105
70	80	150	95	140
250	100	200	135	175
800	195	270	165	205
3000	235	300	200	240

**S-703.01--General.** All aggregate sources shall be approved by MDOT prior to use. All approved aggregate sources will be re-examined periodically for conformance to the quality requirements set herein.

When reference is made to the Los Angeles Test (AASHTO Designation: T 96), the percentage of wear is based on 500 revolutions, unless otherwise specified.

The term "thin or elongated piece" is intended to mean a piece whose length is more than five times its average thickness. Suspected pieces will be chosen from a representative sample, and the length and average thickness will be determined visually.

The term "fractured face" is intended to mean that the approximate area of a fractured face shall not be less than the approximate cross-sectional area at the minor axis of the particle: This area will be visually determined. A piece of aggregate with a small chipped area will not be considered as crushed.

All concrete produced for use in State Aid work shall be manufactured from aggregates which have been tested and accepted by MDOT or other approved labs.

These general provisions shall apply, as applicable, to all the subsections of this section.

**S-703.02--Fine Aggregate For Portland Cement Concrete.**

**S-703.02.1--General Requirements.** Fine aggregate for portland cement concrete used in construction of culverts, headwalls, retaining walls, steps, or other minor structures shall consist of natural sand or manufactured limestone sand. Fine aggregate used in major construction, such as concrete pavements and bridges, shall be natural sand unless otherwise designated on the plans or in the special provisions. Natural sand, or manufactured limestone sand, shall be composed of clean, hard, durable, and uncoated particles free of deleterious substances and organic impurities. Fine aggregate from more than one source shall not be used alternately, or mixed, without the written consent of the Engineer. Approval of fine aggregate sources will be based on the following:

- (1) Soundness of aggregates shall meet the requirements set-out in S-703.02.2.3.
- (2) Expansion of mortar bars shall not exceed 0.5% in six months or 1.0% in one year when tested in accordance with ASTM Designation: C 227.

A source of sand may be rejected if experience proves that concrete made from the source does not have a satisfactory service record.

Unless indicated otherwise, fine aggregate shall meet the requirements hereinafter specified.

**S-703.02.2--Detail Requirements.**

**S-703.02.2.1--Deleterious Substances.** The quantity of deleterious substances shall not exceed the following limits:

<u>Deleterious Substances</u>	<u>Maximum Permissible Limits (% by Weight)</u>
Clay lumps .....	0.3
Coal and Lignite (see Note) .....	0.5
Material Passing the No. 200 sieve .....	2.0
Other deleterious substances such as shale, alkali, mica, coated grains, and soft and flaky particles .....	2.0
Total shale, coal, lignite, clay lumps, and other deleterious substances .....	3.0

Note: No coal or lignite will be permitted in the aggregate used for constructing superstructures of bridges.

**S-703.02.2.2--Gradation Requirements.** Fine aggregate for concrete shall be well graded from coarse to fine and shall conform to the following:

<u>Square Mesh Sieve</u>	<u>Percent Passing by Weight</u>
1/2 inch	100
3/8 inch	97-100
No. 4	92-100
No. 8	75-100
No. 16	45-90
No. 30	25-70
No. 50	3-35
No. 100	0-10

The gradation of material from any one source shall be reasonably uniform and not subject to the extreme gradation shown above. The degree of uniformity will be determined by fineness modulus determination from representative samples submitted from the sources the Contractor proposes to use.

Fine aggregate from any one source having a variation in fineness modulus greater than 0.20 from the approved base modulus of the source may be rejected or may be accepted subject to changes in the proportions, if and as directed by the Engineer.

When the slip-form method for placement of concrete pavement is used, the fine aggregate gradation requirements will be modified if necessary.

**S-703.02.2.3--Soundness.** When subjected to five cycles of soundness test by the use of magnesium sulfate (AASHTO Designation: T 104), the weighed percentage of loss shall not be more than 15.

**S-703.02.2.4--Additional Requirements.** Fine aggregate shall also meet the organic impurities and mortar-making properties specified in AASHTO Designation: M 6.

**S-703.03--Coarse Aggregate For Portland Cement Concrete.**

**S-703.03.1--General Requirements.** Coarse aggregate shall consist of gravel or crushed limestone unless otherwise designated or permitted on the plans or in special provisions.

The gravel or crushed limestone shall be hard, durable particles that are thoroughly clean, free from adherent coatings of injurious character, and reasonably free of soft or disintegrated pieces, frozen lumps, vegetable, or other deleterious matter. Coarse aggregate from more than one source shall not be used alternately, or mixed, without the written approval of the Engineer. Approval of coarse aggregate sources will be based on the following:

- (1) Soundness of aggregates shall meet the requirements set out in S-703.03.2.3.
- (2) Resistance to abrasion shall meet the requirements set out in S-703.03.2.2.
- (3) Expansion of mortar bars shall not exceed 0.5% in six months or 1.0% in one year when tested in accordance with ASTM Designation: C 227.

A source of coarse aggregate may be rejected if experience proves that concrete made from the source does not have a satisfactory service record.

**S-703.03.2--Detail Requirements.**

**S-703.03.2.1--Deleterious Substances.** The quantity of deleterious substances shall not exceed the following maximum limits:

Deleterious Substance	For General Use	For Bridge Superstructures
	(Percent by Weight)	
Shale	1.00	1.00
Coal, Lignite, or combination of the two	0.5	None
Clay lumps	0.3	0.3
Material passing the No 200 sieve:	1.5	1.5
Limestone	1.0	1.0
Other Materials		
Thin or elongated pieces (S-703.01)	15.0	15.0
Soft fragments	3.0	3.0
Free Shells	1.0	1.0
Sticks (oven-dry)	None	None
Shale, coal, lignite, clay lumps, and soft fragments, total	3.0	2.5
Other deleterious substances	1.0	1.0

**S-703.03.2.2--Percentage of Wear.** When coarse aggregate is subjected to the Test for Abrasion of Coarse Aggregate, AASHTO Designation: T 96, the percentage of wear shall not be more than 40.

**S-703.03.2.3--Soundness.** When subjected to five cycles of soundness test by the use of magnesium sulfate, the weighted percentage of loss shall not be more than 15.

**S-703.03.2.4--Gradation.** Coarse aggregate for cement concrete, of the type designated, shall be well-graded from coarse to fine, and shall conform to the following:

**Table of Sizes and Gradation of Coarse Aggregate  
for Portland Cement Concrete**

Square Mesh Sieves	Percent Passing (by Weight)			
	Size No. 47.5	Size No. 75	Size No. 100	Size No. 200
2 inch	100			
1-1/2 inch	95-100	100		
1-1/4 inch *				
1 inch		80-100	100	
3/4 inch	35-70		80-100	100
1/2 inch		25-60		90-100
3/8 inch	10-30		20-55	40-70
No. 4	0-5	0-10	0-10	0-15
No. 8		0-5	0-5	0-5

\*NOTE: A maximum tolerance of three percent retained on the one-inch sieve will be allowed for aggregate Size No. 67 provided all of the material passes a one and one-fourth-inch sieve. This tolerance is not applicable for Class F and Class FX Concrete.

The gradation from any one source shall be reasonably uniform and not subject to the extreme limits of gradation shown in the table.

For the purpose of determining the degree of uniformity, a fineness modulus determination will be made upon representative samples from the sources proposed for use by the Contractor. Coarse aggregate from any one source, having a variation in fineness modulus greater than 0.20 from the approved base modulus of the source may be rejected or may be accepted subject to changes in the proportions used, as directed.



**S-703.04--Aggregate for Crushed Stone Courses.**

**S-703.04.1--Coarse Aggregate.** Coarse aggregate, defined as material retained on No. 8 sieve, shall be either crushed stone, slag, granite, shell; gravel, or combination thereof. When the required properties of the mix are not obtained with uncrushed gravel, the addition of crushed gravel or other approved material is required.

Individual sources of coarse aggregate shall conform to the following quality requirements:

Percentage of wear shall not exceed 45 when tested in accordance with AASHTO Designation: T 96.

The coarse aggregate shall have a minimum dry rodded unit weight of 70 pounds per cubic foot when tested in accordance with AASHTO Designation: T 19.

**S-703.04.2--Fine Aggregate.** Fine aggregate, defined as material passing no. 8 sieve, shall consist of hard, durable particles of naturally disintegrated rock, or material obtained by crushing stone, slag, gravel or combination thereof. Fine aggregate, when manufactured, shall be manufactured from material meeting the quality requirements for coarse aggregate, and it shall be free of lumps of clay and friable particles, loam, organic or foreign matter.

Individual sources of fine aggregate shall be non-plastic when tested in accordance with AASHTO Designation: T 90.

Natural deposits of fine aggregate shall contain no more than 10 percent by weight passing the No. 200 sieve when tested in accordance with AASHTO Designation: T 11.

Fly ash, when used as a portion of the fine aggregate to obtain desired properties of the mixture, shall be from an approved source.

When the fine aggregate is combined with other aggregate fractions in the proper proportion, the resultant mixture shall meet the requirements of S-703.04.3 and the job-mix formula.

**S-703.04.3-Gradation.** Aggregates for crushed stone shall be well-graded from coarse to fine, and shall conform to the following:

**TABLE OF SIZES AND GRADATION OF CRUSHED STONE AGGREGATE**

Sieve Size	Percent Passing by Weight		
	Size $\frac{3}{4}$ inch and Down	Size No. 610	Size No. 825 B
2 inch			100
1 1/2 inch		100	90 - 100
1 inch	100	90 - 100	75 - 98
3/4 inch		70 - 100	
1/2 inch		62 - 90	60 - 85
3/8 inch	50 - 85	50 - 80	
No. 4	35 - 65	40 - 65	40 - 70
No. 8			28 - 54
No. 10	25 - 50		
No. 16			19 - 42
No. 40	15 - 30	12 - 26	
No. 50			9 - 32
No. 200	5 - 15	5 - 12	4 - 18

**S-703.05--- Blank.**

**S-703.06--Aggregates for Hot Mix Asphalt.**

**S-703.06.1--Coarse Aggregates.** Coarse aggregate, material retained on the No. 8 sieve, shall be either crushed stone, slag, or granite; shell; expanded clay; expanded shale; crushed gravel or combination thereof. Crushed reclaimed concrete pavement shall also be allowed as a coarse aggregate provided it meets the quality requirements below and the final product produced therefrom meets all other specification requirements.

The percentage of wear shall not exceed 45 when tested in accordance with AASHTO Designation: T 96.

When tested in accordance with AASHTO Designation: T 19, the dry rodded unit weight of all aggregates except expanded clay and shale shall not be less than 70 pounds per cubic foot, and crushed slag used in the surface course shall have a dry rodded unit weight of not more than 90 pounds per cubic foot except the maximum unit weight is waived for chromium slag.

The coarse aggregate shall be free of any injurious coating which will prohibit the adherence of asphalt to the aggregate particles.

The percentage of loss shall not exceed 20 when tested for soundness using magnesium sulfate in accordance with AASHTO T 104.

Shell shall consist of durable, washed particles of dead clam or dead reef oyster shell, or combination thereof. The shell shall be free of objectionable matter such as sticks, mud, clay lumps, cannery or live shell, or other deleterious matter. Not more than five percent by weight of the dredged material shall pass the No. 200 sieve; any such material shall be dispersed throughout the mass.

**S-703.06.2--Fine Aggregates.** Fine aggregate, material passing the No. 8 sieve, shall consist of hard, durable particles of naturally disintegrated rock, or material obtained by crushing stone, slag, gravel, reclaimed concrete pavement, or combinations thereof. Fine aggregate produce from crushing reclaimed concrete pavement shall be manufactured from material meeting the quality requirements for coarse aggregate.

Fine aggregate shall be free of lumps of clay and friable particles, loam, organic or foreign matter.

Fine aggregate produced by crushing stone, slag or gravel shall be manufactured from aggregate meeting the quality requirements of coarse aggregate.

Individual sources of fine aggregate shall be non-plastic when tested in accordance with AASHTO Designation: T 90.

Natural deposits of fine aggregate shall contain no more than 10 percent by weight passing the No. 200 sieve when tested in accordance with AASHTO Designation: T 11.

Individual fine aggregate components shall be of such consistency and dryness that a uniform and even flow from the cold feed will be provided.

Fly ash shall not be used in hot mix asphalt pavements.

**S-703.07--Granular Materials.**

**S-703.07.1--General.** Granular materials shall be composed of a natural or manufactured mixture of soil binder and sand; soil binder, sand and gravel; stone; slag; or combinations thereof. The mixture shall have satisfactory cementing qualities and shall be homogeneous in character and reasonably free of clay balls, vegetable matter, or other deleterious substances that cannot be classed as serviceable.

To insure adequate soil drainage through the shoulders, no material used above the design soil in the construction of shoulders shall have a minus No. 200 sieve fraction, liquid limit, or plasticity index appreciably exceeding like characteristics in the adjacent subbase or base courses.

**S-703.07.1.1--Fine Aggregate (Portion Passing The No. 10 Sieve).** The fine aggregate shall be composed of a natural or artificial mixture of soil binder and granular material.

The soil binder shall be clay or silt or other materials, or combinations thereof having satisfactory cementing qualities, homogeneous in character, and reasonably free of vegetable matter, clay balls, or other deleterious substances that cannot be classed as serviceable. The granular portion shall be composed of sand, stone, or slag screening and shall be hard and durable and preferably sharp.

**S-703.07.1.2--Coarse Aggregate (Portion Retained on the No. 10 Sieve).** The coarse aggregate shall be composed of gravel, stone, slag, or combinations thereof, and shall consist of hard, durable particles reasonably free of vegetable matter or other deleterious substances. Materials that break up and weather rapidly when alternately frozen and thawed or wetted and dried shall not be used.

Coarse aggregate, when tested in accordance with AASHTO Designation: T 96, shall have a percentage of wear not to exceed 50.

**S-703.07.2--Gradation.** The gradations shown in the following tables are the maxima and minima for all sources, and the gradation from any one source shall be reasonably uniform and not subject to the extreme limits in the tables. It shall be the responsibility of the Contractor to furnish a material which will have sufficient silt and clay, within the ranges permitted in the tables, to insure that the material will, when processed as specified, bind together and form a stable course and will, when properly compacted, have the required density.

The gradation of the composite mixture shall meet the applicable requirements of the following tables:

**Percentage (by weight) Passing Square Mesh Sieves**

Class	1 & 2	3 & 4	5 & 6	7	8	9	10
Passing 3 inch	100	100	100	100	100	100	100
1-1/2 inch	85-100	85-100	85-100				
1 inch	65-100	65-100	65-100				
1/2 inch	35-90	35-90	35-100				
No. 4	30-70	30-75	30-85				
No. 10	30-50	30-57	30-65	30-100	30-100	30-100	30-100

Note: The minimum percentage passing the No. 10 sieve may be lowered to 25% by the Engineer if proper placement characteristics and stability can be obtained by the coarser gradation.

**Material Passing the No. 10 Sieve**

Class	1	2	3	4	5	6	7	8	9	10
No. 10	100	100	100	100	100	100	100	100	100	100
No. 40	20-80	20-90	20-90	20-90	20-100	20-100	40-80	20-85	20-100	20-100
No. 60	15-70	15-80	15-80	15-80	15-80	15-80	30-70	15-70	15-85	15-100
No. 200	8-40	6-40	8-40	6-40	8-40	6-40	10-40	8-40	6-40	8-60

Material Passing the No. 40 Sieve shall meet the following:

Group Symbol	LL Max.	PI	
		Min.	Max.
A	25		6
B	25		8
C	30		10
**D	35		15
**E	35	6	15

General Note: Material will be designated in the contract by Class \_\_\_\_\_, Group \_\_\_\_\_.

\*\* In the case of Group D material, the range of PI shall be no more than nine in any half-mile section. When Group E material is specified in the contract, that portion to be treated with cement may be less plastic or non-plastic except that the range in PI shall be no more than nine in any half-mile section.

**S-703.07.3--Sampling and Testing.** The material shall be sampled and tested as outlined in S-700.03.

**S-703.08--Mechanically Stabilized Courses.** Specified aggregates meeting the requirements of S-703.20 when combined with soils or other aggregates as required will be tested for gradation and plasticity of the composite mixture.

In the case of gravel, stone, or slag aggregates or combinations thereof, the composite mixture will be designated in the contract as Type A, Type B, or Type C. In the case of reef shell or clam shell aggregates or combinations thereof, the composite mixture will be designated in the contract as Type D.

The composite mechanically stabilized mixture of the type and group specified in the contract shall meet the following requirements:

Percentage (by weight) Passing Square Mesh Sieves				
Type	A	B	C	D
3 inch	100	100	100	
1-1/2 inch	85 - 100	85 - 100	85 - 100	95 - 100
1 inch	65 - 100	65 - 100	65 - 100	
1/2 inch	35 - 90	35 - 90	35 - 100	
No. 4	30 - 70	30 - 75	30 - 85	
No. 10	30 - 50	30 - 57	30 - 65	
No. 40				55 (Max.)

Material Passing the No. 40 Sieve shall meet the following:

Group Symbol	LL Max.	PI	
		Min.	Max.
A	25		6
B	25		8
C	30		10
**D	35		15
**E	35	6	15

Note: Desired product will be designated in the contract as Type \_\_\_\_\_, Group \_\_\_\_\_

\*\* In the case of Group D material, the range of PI shall be no more than nine in any half-mile section. When Group E material is specified in the contract, that portion to be treated with cement may be less plastic or non-plastic except that the range in PI shall be no more than nine in any half-mile section.

**S-703.09 thru S-703.13 -- Blank.**

**S-703.14--Aggregate for Bituminous Surface Treatments.**

**S-703.14.1--General Requirements.** Aggregate for bituminous surface treatments and liquid seals shall consist of crushed stone, crushed slag, gravel, or expanded clay as specified in the contract.

Only one kind and type of aggregate shall be used on a single course unless otherwise authorized in writing by the Engineer.

**S-703.14.2--Detail Requirements.**

**S-703.14.2.1--Gradation.** Aggregates shall conform to the gradation requirements contained in the following table:



**GRADATION REQUIREMENTS FOR COVER AGGREGATE**

Square Mesh Sieve	Coarse Aggregate Cover Material		Seal Aggregate Cover Material			
	Slag, Stone, Granite or Gravel (Crushed or Uncrushed)		Slag, Stone, Granite or Crushed Gravel		Slag or Expanded Clay	
	Size No.	Size No.	Size No.	Size No.	Size No.	Size No.
	5	56	6	7	7	8
Percent Passing Square Opening Sieves						
1 1/2 inch	100	100	100	100	100	100
1 inch	90-100	90-100	100	100	90-100	100
3/4 inch	20-55	40-85	90-100	100	100	100
1/2 inch	0-10	10-40	20-55	90-100	40-85	85-100
3/8 inch	0-5	0-15	0-15	40-85	0-15	10-30
No. 4	0-5	0-5	0-5	0-15	0-5	0-10
No. 8				0-5	0-5	0-5
No.16				5-30	0-5	0-5

The size coarse aggregate cover material and the size seal aggregate cover material shall be as specified in the bid schedule of the contract; however, only one type of aggregate shall be used unless otherwise authorized by the Engineer in writing.

**S-703.14.2.2--All Materials.** The quantity of deleterious substances shall not exceed the limits set out in S-703.03.2.1 for general use.

When subjected to five cycles of Soundness Test for Coarse Aggregate by use of magnesium sulfate, the weighted percentage of loss shall not be more than 15.

The percentage of wear, when tested for abrasion in accordance with AASHTO Designation: T 96, shall not be more than 40%.

**S-703.14.2.3--Crushed Stone.** Crushed stone shall consist of clean, tough, durable, uncoated fragments free from an excess of soft or disintegrated pieces.

**S-703.14.2.4--Crushed Slag.** Crushed slag shall be air-cooled slag consisting of angular fragments, reasonably uniform in density and quality, and reasonably free of dirt or other objectionable matter. Crushed slag shall have a dry-rodded weight of 70 to 90 pounds per cubic foot when tested in accordance with AASHTO Designation: T 19 and shall not contain more than 10 percent by weight of glassy particles. The maximum unit weight is waived for chromium slag.

**S-703.14.2.5--Crushed Gravel.** Crushed gravel shall be composed of clean, tough, durable particles of gravel, free from excess dirt or other objectionable matter. At least 85% by weight of the particles retained on the No. 10 sieve shall have one or more fractured faces.

**S-703.14.2.6--Uncrushed Gravel.** Uncrushed gravel shall be composed of clean, tough, durable particles free from excess vegetable or other objectionable matter. It shall meet the requirements specified above for all materials as to deleterious substances.

**S-703.14.2.7--Expanded Clay.** Expanded clay aggregate shall be the product of a plant approved by the Engineer. It shall conform to the gradation requirements in the preceding table and to requirements of ASTM Designation: C 330, with the following exception: The loss by abrasion shall not be more than 40% when subjected to the Los Angeles Abrasion Test, AASHTO Designation: T 96.

When used for sealing joints, the soundness and abrasion requirements will be waived.

**S-703.15--Blank.**

**S-703.16--Mineral Filler.** Mineral filler shall consist of shell dust, limestone dust, portland cement, or other calcareous type materials having a high affinity for asphalt. The source of the material shall be approved by the Engineer.

Mineral filler shall meet the following gradation requirements:

Passing the No. 30 sieve, % .....	100
Passing the No. 50 sieve, not less than, % .....	95
Passing the No. 200 sieve, not less than, % .....	65

**S-703.17--Blank.**

**S-703.18--Mortar Sand.** Sand for mortar shall consist of hard, strong, durable, uncoated mineral or rock particles, free of injurious amounts of organic or other deleterious substances. It shall not contain, by weight, more than three percent clay or inorganic silt or combination thereof.

Mortar sand shall be uniformly graded from coarse to fine within the following limits:

<u>Sieve Size</u>	<u>% Passing</u>
No. 4	100
No. 8	97-100
No. 50	8-40
No. 100	0-10
No. 200	0-5

Mortar sand shall meet other requirements of AASHTO Designation: M 45.

**S-703.19--Blank.**

**S-703.20--Aggregate for Stabilizer.**

**S-703.20.1--General Requirements.** The material for stabilizer aggregate shall meet the requirements hereinafter specified for each type.

The gradation limits shown below are the maxima and minima for all cases, and a closer control appropriate to the job materials will be required for the specific project. Each type of aggregate shall be uniformly graded from coarse to fine. Skip-graded material will not be acceptable.

**S-703.20.2--Detail Requirements.**

**S-703.20.2.1--Gravel, Stone, or Slag Coarse Stabilizer.** Gravel or stone shall be composed of hard, tough, durable particles reasonably free of injurious or deleterious substances. The percentage of wear, when tested in accordance with AASHTO Designation: T 96, shall not exceed 50%. Slag shall be air-cooled slag, consisting of angular fragments, reasonably uniform in density and quality, and reasonably free of dirt or other objectionable matter. The weight shall be not less than 70 pounds per cubic foot. The percentage of wear, when tested in accordance with AASHTO Designation: T 96, shall not exceed 50%.

**S-703.20.2.2--Shell.** Shell shall consist of durable, washed particles of slaked clam or reef shell or combination thereof. The shell shall be free of objectionable matter such as sticks, mud, clay lumps, or other deleterious matter. Not more than four percent by weight of clay and sand will be permitted and such material shall be dispersed throughout the mass.

Clam shell shall consist of washed dead clam shell. Reef shell shall consist of washed dead oyster shell and not contain cannery or live shell.

**S-703.20.2.3--Medium and Fine Stabilizer.** Medium aggregate stabilizer and fine aggregate stabilizer shall consist of sand, stone, shell, and/or slag screenings.

Slag screenings, sand, or stone shall be composed of hard, durable particles reasonably free of injurious amounts of soft or flaky particles, dust lumps, organic, or other deleterious substances. Shell shall comply with the requirements set out S-703.20.2.2.

**S-703.20.3--Gradation.** The gradation of the various types of stabilizer shall be as follows:

**PERCENT PASSING (BY WEIGHT)**

Type	Shell	Coarse		Medium	Fine
Material		Gravel, Stone, or Slag		Gravel, Stone, Slag or Shell	
Square Opening Sieves		Size I	Size II Note (1)		
2 1/2"	90-100				
2"		100			
1 1/2"		90-100	100		
1"		80-100	97-100		
3/4"		55-100	55-100		
1/2"		35-85	35-85	100	
3/8"		12-65	12-65	97-100	
No.4 Note (2)		0-30	0-30	92-100	
No. 10		0-8	0-8	80-100	100
No. 40				10-40	80-100
No. 60				0-20	30-100
No. 100					15-80
No. 200	0-5	0-4	0-4	0-5	0-30
PI Material					
Passing No. 40				6 or less	0

Note (1): Size II is intended for use in bases in which portland cement is used.

Note (2): Ground shell shall contain at least 97% passing the No. 4 sieve.

**S-703.20.4--Stabilizer Aggregate, Local Materials.** When local materials are designated for use as stabilizer aggregate, their requirements will be shown on the plans or in the special provisions.

**S-703.21--Borrow Excavation.** Borrow excavation shall be composed of a natural or manufactured mixture of sand, silt, and clay or combinations of sand, silt, clay, gravel or stone. The material shall have satisfactory cementing qualities, shall be reasonably free of vegetable matter or other deleterious substances that cannot be classed as serviceable, and shall be such that when properly compacted will form a dense mass. When rock or stone is used in the embankment, it shall be so graded and manipulated that the embankment will contain no appreciable interstices.

Borrow excavation from outside the right-of-way is divided into classes, each class conforming to the requirements set-out in the following table:

Class	1	2	3	4	5	6	7	8	9	10
Percent Passing No. 200 Sieve (Max.)	25	35	10	35	35	35	100	100	100	100
Fraction Passing No. 40 Sieve - Liquid Limit (Max.)	--	40	--	45	40	45	40	55	40	55
Plasticity Index, (Max.)	6	10	np	10	20	25	10	10	20	--

The Class of material will be specified in the contract.

When the contract contains a numerical designation after the class number, it shall be understood to indicate the requirement that the material shall have a minimum PI of not less than that indicated by the numerical designation. For example, Class 9-6 requires Class 9 material having a minimum PI of 6; or a Class 9-10 requires Class 9 material having a minimum PI of 10, etc.

When a minimum PI is specified, the maximum plasticity index and the maximum liquid limit, as indicated in the table, will be raised the numerical designation for minimum PI, except that in the case of Class 8 and Class 10 the maximum liquid limit shall remain as indicated in the table above.

For the design soil portion of the embankment all of the material shall pass a 3 inch sieve. Individual contracts may further restrict the maximum size of material in the top portion of the design soil.

**S-704.01--Permeable Material.** Permeable material for use in backfilling trenches, under, around, and over underdrains and permeable material for blankets or other subdrainage purposes shall consist of hard, durable, clean sand, gravel, crushed stone, or crushed slag, and shall be free from organic material, clay balls, or other deleterious substances. These materials shall be as designated by Type as set out below.

**S-704.02--Type A. Filter Material.** Type A filter material shall meet the requirements for Size 7 seal cover aggregate, or Size 7, 57, or 67 coarse aggregate for portland cement concrete, or Size II gravel coarse stabilizer as set out in S-703. The crushing requirement for gravel seal cover aggregate is not applicable.

**S-704.03--Type B. Filter Material.** Type B filter material shall be concrete sand conforming to the requirements of S-703.02, except that the requirements for fineness modulus (FM) will not apply.

**S-704.04--Type C. Filter Material.** Type C filter material shall consist of sand, stone, and/or slag screenings composed of hard, durable particles reasonably free of injurious amounts of soft or flaky particles, dust, lumps, organic, or other deleterious substances.

The gradation of the material shall be as follows:

Sieve Size	Percent Passing
1/2"	100
No. 4	80-100
No. 16	37-80
No. 50	5-30
No. 100	0-10

**S-704.05--Type D. Impervious Material.** Type D impervious material shall consist of natural soil, soil aggregates, or a blend of natural soil and aggregates. The material shall be reasonably free of sticks, roots and other objectionable matter, shall be classified as Group A-6 or A-7, and shall conform with the following:

Percent Passing No. 10 Sieve	80-100
Percent Passing No. 200 Sieve	36 (Min.)
Liquid Limit	50 (Max.)
Plasticity Index	12-25
pH	4.5-8.0

STATE AID **SECTION S-705 - STONE BLANKET PROTECTION AND** AID 2004  
**FILTER BLANKET MATERIALS**

**S-705.01--Stone Blanket Protection.** In addition to meeting the quality requirements of AASHTO Designation: M 80, stone blanket protection shall be in accordance with AASHTO Designation: M 43, Size No. 357.

**S-705.02--Stone Filter Blanket.** In addition to meeting the quality requirements of AASHTO Designation: M 80, Class E, filter blanket material shall conform to the gradation requirements of AASHTO Designation: M 43, Size No. 467.

**S-705.03--Sand Filter Blanket.** The sand filter blanket shall conform to the requirements of S-703.02 for concrete sand.

**S-705.04--Stone Riprap.** Aggregate for loose riprap, stone riprap for foundation protection, or that to be grouted shall consist of field stone, broken concrete, or rough, unhewn quarry stone as nearly rectangular in section as is practicable. The stone shall be dense, free of clay or shale seams, resistant to the action of air and water, and suitable in all other respects for the purpose intended. Quality requirements for rock to be furnished under these specifications will be checked or tested as determined by the MDOT Materials Engineer prior to use and subsequently if deemed appropriate.

Stones for riprap, of the size specified, shall meet the requirements for size by weight as specified in the following table:



**PERCENTAGE LARGER THAN**  
**(by Weight of The Mass)**

Size

ROCK SIZE	8 Ton	4 Ton	2 Ton	1 Ton	1/2 Ton	1/4 Ton	300 Lbs.	200 Lbs.	100 Lbs.
8 Ton	50	0							
4 Ton	85	50	0						
2 Ton	--	95	50	0					
1 Ton	--	--	95	50	0				
1/2 Ton	--	--	--	95	50	0			
1/4 Ton	--	--	--	--	95	50			
300 Lbs.	--	--	--	--	--	--	0		
200 Lbs.	--	--	--	--	--	--	--	0	
100 Lbs.	--	--	--	--	--	--	--	--	0
75 Lbs.	--	--	--	--	--	90	--	--	--
60 Lbs.	--	--	--	--	--	--	80	--	--
40 Lbs.	--	--	--	--	--	--	--	80	--
20 Lbs.	--	--	--	--	--	--	90	--	80
10 Lbs.	--	--	--	--	--	--	--	90	--
5 Lbs.	--	--	--	--	--	--	--	--	90

This table sets out minimum requirements for the large stone per size designation. The Contractor shall furnish material well graded with the smaller stones such that a homogeneous blanket of riprap will result with all interstices reasonably well filled with rock.

**S-706.01--Brick.**

**S-706.01.1--General.** Brick shall have a fine-grained, uniform, and dense structure, and be free of lumps of lime, laminations, cracks, checks, soluble salts, or other defects which may in any way impair the strength, durability, appearance or usefulness of the brick for the purpose intended. Bricks shall emit a clear, metallic ring when struck with a hammer.

**S-706.01.2--Building Brick.** Unless otherwise stipulated, building brick shall conform to AASHTO Designation: M 114, Grade SW.

**S-706.01.3---Sewer and Manhole Brick.** Unless otherwise stipulated, brick for sewer and manholes shall conform to AASHTO Designation: M 91, Grade SM.

**S-706.02--Concrete Brick.** Concrete brick shall conform to ASTM Designation: C 55, Grade N, Type I.

**S-706.03--Concrete Masonry Blocks.** Concrete masonry blocks may be rectangular or segmented and, when specified, shall have ends shaped to provide interlock at vertical joints. The blocks shall conform to the requirements of ASTM Designation: C 139; or, for hollow blocks, to ASTM Designation: C 90, Grade N, Type I. Dimensions and tolerances shall be specified.

**S-706.04--Right-of-Way Markers.**

**S-706.04.1--General.** Right-of-way markers shall be constructed in conformity with the details shown on the plans and shall meet the requirements hereinafter set forth. When more than 20% of the units in a lot is rejected, the entire lot will be rejected.

**S-706.04.2--Manufacture.**

**S-706.04.2.1--Description.** The exposed portion of the marker shall present a smooth, uniform surface, free of honeycomb, chips, or other defects. The shape, dimensions, and placement of steel shall be in accordance with details shown on the plans. All letters, figures, or other markings shall be true to type and size shown on the plans, and shall be legible.

**S-706.04.2.2--Materials.** The materials used in the manufacture shall conform to the following:

**S-706.04.2.2.1--Cement.** The cement used shall meet the requirements of S-701.

**S-706.04.2.2.2--Aggregates.** The aggregates used shall conform to the requirements of S-703.02 and S-703.03, except that the requirements for gradation will not apply.

**S-706.04.2.2.3--Reinforcing Steel.** Reinforcing steel shall conform to the requirements of S-711.01.

**S-706.04.2.2.4--Proportions.** The concrete shall have a minimum cement factor of 1.25.

**S-706.04.2.2.5--Strength Requirements.** The strength of the right-of-way markers shall be determined by the beam method. Under the beam method, a completed unit is loaded at the midpoint of an 18 inch span with three edge bearing; the unit shall develop a strength of not less than 12,000 pounds, total load. Two specimens will be tested for each 200 units, or increment thereof; one to destruction and one to the ultimate load of 12,000 pounds.

**S-707.01--General.** Joint fillers and seals for concrete bridges, concrete pavements or base course, and culvert pipe shall meet the requirements indicated on the plans or in the special provisions, and shall conform to the following applicable subsections.

**S-707.02--Joint Fillers.**

**S-707.02.1--Poured Joint Filler.**

**S-707.02.1.1--Asphalt Joint Material.** Poured asphalt filler shall be blown asphalt, Grade AC-13, conforming to the requirements of S-702.12, Table I.

**S-707.02.1.2--Polymerized Emulsified Asphalt Joint Material.** Cold applied polymerized-emulsified asphalt joint material shall meet the following requirements when tested in accordance with AASHTO Designation: T 59 and as specified below:

	Minimum	Maximum
<b>Tests on Emulsion</b>		
Viscosity, Saybolt Furol @ 122°F, seconds	50	450
Storage Stability, 24 hr., % *	-	1
Classification Test	Pass	
Particle Charge Test	Positive	
Cure Test **	Pass	
Stretch Test ***	Pass	
Distillation:		
Oil distillate by volume of emulsion %	-	2
Residue from distillation, %	65	-
<b>Tests on Residue from Distillation</b>		
Penetration, 77°F, 100 g., 5 seconds	80	150
Ductility, 77°F, cm	40	-
Solubility in Trichloroethylene, %	97.5	-

\* Note 1: Upon examination of the test cylinder after standing undisturbed for 24 hours, the surface shall show no white, milky colored substance but shall be a homogeneous brown color throughout.

\*\* Note 2: Cure Test - Pour approximately one milliliter of the emulsion onto a metal surface. Allow to cure at a minimum temperature of 80°F under a bright light for four hours. Outside in the sun may be used as the test site. After the four-hour curing period, the material shall show no tackiness or tendency to stick to the finger when pressed.

\*\*\* Note 3: Stretch Test - Pour onto a one-quart friction lid, or similar flat container, enough emulsion to cover the surface. While the emulsion is still brown, embed with thumb pressure several clean, sharp edged rocks of 3/8 to 1/2 inch size. Cure in oven at 100°F for a minimum of eight hours. Remove from oven and allow to cool at room temperature for one hour. Upon lifting a rock from the surface, the asphaltic material must stretch for a distance of three inches before breaking.

**S-707.02.1.3--Concrete Joint Sealer Compound - Hot-Poured Elastic Type.** Concrete joint sealer compound, hot-poured elastic type, shall conform to the requirements of AASHTO Designation: M 173.

**S-707.02.1.4--Silicone Sealant.** The silicone sealant must have been approved for listing in the MDOT's "Approved Sources of Materials" prior to its use. The silicone sealant shall be a single component low modulus non-acetic acid cure sealant which does not require a primer for bond to concrete. Unless specifically designated otherwise, silicone sealant shall be either the standard non-sag type or the self-leveling type meeting the following requirements:

### PHYSICAL REQUIREMENTS

<b>Property</b>	<b>Standard Non-Sag Type</b>	<b>Self-Leveling Type</b>
Shore A Durometer Hardness, 7-day cure @ 73.4 ±3.6°F & 45% to 55% R.H., ASTM Designation: D 2240	10 - 25	Maximum
Elongation, 7-day cure @ 73.4 ±3.6°F & 45% to 55% R.H., ASTM Designation: D 412, Method A, Die C, minimum	500%	500%
Tensile Stress @ 150% Elongation, 7-day cure @ 73.4 ±3.6°F & 45% to 55% R.H., ASTM Designation: D 412, Method A, Die C	20 - 45 psi	10 - 30 psi
Flow/Sag, ASTM Designation: C 639, maximum	0.3 inch	Self-Leveling
Tack-Free Time, 73.4 ±3.6°F & 45% to 55% R.H., 90 minutes ASTM Designation: C 679, maximum		180 minutes
Shelf Life from Date of Manufacture, minimum	6 months	6 months

The manufacturer of the joint material shall furnish certified test results of each lot of material furnished to each project. Each lot of the sealant shall be delivered in containers plainly marked with manufacturer's name or trade mark, lot number and date of manufacture.

**S-707.02.1.5--Backer Rod for Use with Hot and Cold Poured Joint Sealer.** The backer rod shall be a closed-cell foam rod made from polyethylene, polyolefin or similar type material and must have been approved for listing in MDOT's "Approved Sources of Materials" prior to its use. The backer rod shall not wick water or retain moisture. The backer rod shall meet the following requirements:

Property	Value	Test Method
Density, maximum	2.5 lbs/ft <sup>3</sup>	ASTM D 1622
Tensile Strength, minimum	15 psi	ASTM D 1623
Water Absorption, maximum	0.02 g/cm <sup>3</sup>	ASTM C 1016, Procedure A
Compression Deflection, maximum	25% at 10 psi	ASTM D 1621
Temperature Requirements, minimum	450°F	No visible damage, when in contact with hot sealant

NOTE: The temperature requirement shall not apply for use with cold-poured joint sealer.

**S-707.02.1.6--Tar.** Tar filler shall be produced from suitable gas-house, coke-oven, and/or water-gas tars and shall conform to the following requirements:

	Minimum	Maximum
Float Test at 122°F	75	100
Total Distillate, percent by weight to 572°F	-	25
Water, percent by volume		1
Bitumen soluble in CS <sub>2</sub> , percent	80	-
Softening Point of Residue (R & B), °F		162
Specific Gravity, 60°F/60°F	1.20	1.28

**S-707.02.2--Preformed Joint Filler.** Preformed joint filler shall conform to AASHTO Designation: M 153 for cork or sponge rubber types or AASHTO Designation: M 213 for bituminous types. The type required will be indicated on the plans.

**S-707.02.3--Wood.** Wood board joint filler shall be redwood, cypress, yellow pine, white pine, fir, longleaf pine, Tupelo gum, or other lumber classed as softwood, and shall conform to the following requirements:

Boards shall be free of knots, except that small pin knots 1/4 inch maximum diameter will be permitted. Boards containing occasional knots of larger size may be used, provided the knots are removed and the holes either filled with properly sized plugs of the same type wood or covered with approved thin metal attached to the board. Occasional medium surface checks not to exceed 1/32 inch width and 10 inch length will be permitted, provided the board is free of defects that will impair its usefulness for the purpose intended. Dimensions shall be as shown on the plans, and tolerances of plus or minus 1/16 inch thickness and plus or minus 1/8 inch width will be permitted. For slip-form paving a tolerance of minus 1/4 inch on each end in length will be permitted. The oven-dry weight shall not exceed 38 pounds per cubic foot, and the load required to compress the material in an oven-dry condition to 50% of its thickness before test shall not be more than 2500 psi.

A sample shall be submitted for each shipment of 1000 linear feet or less. Each sample shall consist of a representative section at least 36 inches long and the full depth of the joint. Testing shall be in accordance with AASHTO Designation: T 42, as applicable.

The joint filler shall be a one-piece board or a lamination of like species of the required thickness, depth and lane width length without joints or splicing except that milled shop finger end joints are permissible.

**S-707.02.4--Preformed Joint Insert Material for Concrete Paving.** Preformed joint insert material shall be composed of 1/4 x 2-inch preformed, non-extruding fiber board. The fiber shall be impregnated with asphalt or other approved binding material. The fiber board shall be of such character as not to be deformed or broken by twisting, bending, or other ordinary handling when exposed to atmospheric conditions. Pieces of the joint filler that have been damaged shall be rejected. This material is for use in longitudinal joints.



**S-707.02.5--Preformed Elastomeric Compressive Joint Seals for Concrete.** The preformed elastic joint shall be a polychloroprene joint sealer of the size and shape shown on the plans, bonded to the concrete with a lubricant adhesive and shall conform to AASHTO Designation: M 220.

The lubricant adhesive shall be in accordance with the recommendation of the manufacturer of the joint seals.

The Contractor shall submit the manufacturer's certified test results for each lot of joint seals.

**S-707.03--Blank.**

**S-707.04--Rubber Type Gaskets for Joining Conduit.** Rubber gaskets for pipe joints and revisions in design of pipe for installation of the gaskets shall conform to the requirements of AASHTO Designation: M 315. The Contractor shall submit the manufacturer's certified test results for each consignment of material.

**S-707.05--Bituminous Plastic Sealer for Joining Conduit.** Bituminous plastic sealer shall be composed of steam-refined petroleum asphalt or refined coal tar which has been dissolved in a suitable solvent and stiffened with an inert mineral filler.

The sealer shall be a smooth uniform mixture, not thickened or livered; it shall show no separation which cannot be easily overcome by stirring. The material shall be of such consistency and properties that it can be readily applied with a trowel, a putty knife, or a caulking gun without pulling or drawing. The material, when applied to pipe surfaces, shall exhibit good adhesive and cohesive properties and shall have only slight shrinkage after curing. The material shall be capable of being exposed to below freezing temperatures without incurring damage. When applied in a layer of 1/16 inch to 1/8 inch thick on a tinned metal panel and cured at room temperature for 24 hours, the bituminous plastic sealer shall set to a tough plastic coating, free of blisters. Additional requirements are:

	Minimum	Maximum
Grease cone penetration, unworked, 150 grams, 25°C, 5 sec., ASTM Designation: D 217, mm/10	175	250
Weight, pounds per gallon	9.75	-
Non-volatile, 19 grams, 105°C - 110°C, 24 hrs., %	75	-
Ash, by ignition, %	25	55

**S-707.06--Flexible Plastic Gasket for Joining Conduit.** Gasket joint seals shall be produced from blends of refined hydrocarbon resins and plasticizing compounds reinforced with inert mineral filler and shall contain no solvents. The gasket joint sealer shall not depend on oxidizing, evaporating, or chemical action for its adhesive or cohesive strength and shall be supplied in extruded rope form of suitable cross-section and of such size as to fill the joint space when the pipes are laid. The gasket joint sealer shall be protected by a suitable removable two-piece wrapper. The two-piece wrapper shall be so designed that one-half may be removed longitudinally without disturbing the other half.

The material shall be obtained from approved sources and the approval will be based on results of testing as required herein.

The Engineer may require the performance test described in AASHTO Designation: M 198.

Flexible plastic gasket shall also meet the following requirements:

	<b>Minimum</b>	<b>Maximum</b>	<b>Test Method</b>
<b>Composition</b>			
Bitumen / Petroleum Plastic Content	50	70	ASTM D 4
Ash-Inert Mineral Matter	30	50	AASHTO T 111
Volatile Matter	--	2.0	ASTM D 6
<b>Property</b>			
Specific Gravity at 77°F	1.20	1.35	ASTM D 71
*Ductility at 77°F (cm)	5.0	--	ASTM D 113
*Softening Point	320°F	--	ASTM D 36
*Penetration 77°F, 150 g, 5 sec.	50	120	ASTM D 217

- \* Due to the nature of the material, each sample to be tested must be manually kneaded, in lieu of heating and pouring, into the testing containers.

The Contractor shall furnish the Engineer three copies of the manufacturer's certificate, stating that the flexible plastic gasket meets all the requirements of these specifications and has the properties and characteristics herein specified.

**S-707.07--Neoprene Expansion Joints.**

**S-707.07.1--General.** Neoprene expansion joints shall consist of an integrally molded unit of neoprene and bonded metal components or neoprene extrusions bonded to steel extrusions so arranged as to provide for the expansion and contraction movements of the bridge deck.

**S-707.07.2--Material Requirements.** Materials used in the manufacture of the expansion joints shall meet the following requirements:

Neoprene shall meet the requirements of AASHTO Designation: M 220.

Steel plates bonded in the joints and steel extrusions shall conform to the requirements of ASTM Designation: A 36.

Aluminum plates used in the manufacture of the expansion joints shall conform to the requirements of ASTM Designation: B 209, Alloy 6061-T6.

Anchor bolts or studs shall be of a weldable alloy if arc welding is used, and shall conform to the strength requirements of ASTM Designation: A 307, Grade A Low Carbon Steel Fasteners.

**S-707.07.3--Certification of Materials.** The Contractor shall furnish the Engineer three copies of the manufacturer's certificate, stating that the expansion joint and each component material meets all the requirements of these specifications and have the properties and characteristics herein specified.

## **SECTION S-708 - NON-METAL STRUCTURES AND CATTLEPASSES**

**S-708.01--General.** The structures covered in these specifications are for use as pipe culverts, precast box culverts, cattlepasses, sidedrains, sewers, underdrains, and downspouts.

**S-708.02--Concrete Pipe.** Unless otherwise specified, pipe and tile shall conform to the requirements hereinafter set forth. When more than 20% of the pipe in a lot is rejected, the entire lot of pipe will be rejected.

When elliptical reinforcing is used, lift holes shall be cast in the top and "Top" or "Bottom" shall be clearly inscribed or stenciled on the inside of the pipe to indicate the proper position when laid. When it is found that the position for laying is not marked, or is marked improperly, the entire lot of such pipe will be rejected.

When rubber gasket joints are permitted or specified, the pipe joints shall be so constructed as to accommodate this type of jointing.

### **S-708.02.1--Materials for Use in Concrete Pipe.**

**S-708.02.1.1--Cement.** Portland Cement Types I, II or III, or blended hydraulic cement, shall conform to the requirements set out in S-701.

**S-708.02.1.2--Fly Ash.** Fly ash conforming to the requirements of S- 714.05 may be used to replace portland cement on a one to one replacement rate but not to exceed 20 percent by weight of the portland cement.

**S-708.02.1.3--Fine Aggregate.** Fine aggregate shall consist of natural sand and shall conform to the requirements set out in S-703.02, except that the requirements for gradation are not applicable.

**S-708.02.1.4--Coarse Aggregate.** Coarse aggregate shall consist of gravel or crushed limestone conforming to the requirements of S-703.03, except that the requirements for gradation are not applicable. Concrete pipe made with crushed limestone coarse aggregate will not be permitted for use on a project with a soil pH lower than 4.5.

**S-708.02.1.5--Water.** The water shall conform to the requirements set out in S-714.01.2.

**S-708.02.1.6--Reinforcement.** Reinforcement shall consist of wire conforming to the applicable requirements of S-711.02.

**S-708.02.2--Manufacture. General.** Circular pipe of 54-inch diameter and smaller shall be machine made. Other pipe may be either machine made or wet cast.

All sizes of concrete pipe may be furnished with either bell and spigot or tongue and groove, provided that the minimum thickness of concrete on the groove end is at least 1 ¼ inches. This measurement for thickness will be made at a point 3/8 inch from the outer end of the groove.

When no particular length is specified, the pipe shall be manufactured in standard lengths of at least 2 1/2 feet and not more than eight feet.

The pipe shall be constructed in such a manner and of such design that the joint will meet the same requirements for strength stipulated for the pipe.

**S-708.02.3--Exceptions to AASHTO Standard Specifications.**

**S-708.02.3.1--Liquid Membrane Curing Compound.** Liquid membrane curing compound will not be permitted.

**S-708.02.3.2--Marking.** Required markings shall be placed on the inside wall of the pipe. Machine made pipe shall be inscribed on the outside of the pipe and stenciled on the inside, other pipe may be stenciled. The specification designation for reinforced pipe may be excluded from the required markings.

**S-708.02.3.3--Basis of Acceptance.** All pipe will be tested under Option I, three-edge bearing test, or Option II, cylinder test, as set forth in MDOT SOP.

Pipe having a diameter of 30 inches or less will be tested under Option I.

Pipe larger than 30 inches in diameter will be tested under Option I or II. The pipe producer shall advise the MDOT Testing Engineer in writing of the option under which the pipe will be tested. The option chosen will remain in effect until rescinded in writing.

Flared end sections and cattlepasses will be tested under Option II unless otherwise authorized by the MDOT Testing Engineer.

The specified D-load and compressive strength shall be considered as minimum and allowable failures will not apply.

Normally, neither the absorption test nor the ultimate load will be required.

**S-708.02.3.4--Rejection.** All pipe shall be subject to rejection for nonconformance to the specifications. Individual sections of pipe may be rejected for one or more of the following:

Visible fractures or cracks, except for a single end crack that does not exceed the depth of the joint.

Defects that indicate imperfect proportioning, mixing, and molding.

Surface defects indicating honey-combed or open texture.

Damaged or cracked ends which would prevent a satisfactory joint.

Defects indicating incorrect positioning of reinforcing steel.

**S-708.02.3.5--Repairs.** Repairs will not be permitted in the barrel of the pipe. Repairs may be made on the ends, tongue and groove or bell and spigot, with an approved commercial concrete patching compound used according to manufacturer's recommendations and properly cured.

**S-708.02.3.6--Tongue and Groove.** The thickness of the tongue shall not vary more than 1/4 inch or five percent of the wall thickness, whichever is greater, when measured at the outer edge. The thickness of the groove shall not vary more than 1/4 inch or five percent of the wall thickness, whichever is greater, when measured at a point 3/8 inch from the outer end of the groove. The depth of the groove shall not vary more than 1/4 inch from the length of the tongue.

**S-708.02.3.7--Lift Holes.** Lift holes may be formed, punched, or drilled in plastic concrete. Lift holes may be placed in cured pipe only by drilling with a diamond core-drill bit.

**S-708.02.4--Nonreinforced Concrete Pipe.** In addition to the applicable requirements of S-708.02, nonreinforced concrete pipe shall meet the requirements of AASHTO Designation: M 86 for the class specified. Testing shall be in accordance with AASHTO Designation: T 280.

**S-708.02.5--Reinforced Concrete Pipe.** All reinforced concrete pipe except Class V pipe with diameters of 54 inches and larger shall meet the requirements of AASHTO Designation: M 170 as modified by S-708.02.

Class V pipe with diameters of 54 inches and larger shall meet the requirements of AASHTO Designation: M 170 or M 242 as modified by S-708.02 and herein.

Circular reinforced concrete pipe with S-stirrup reinforcement shall be in accordance with Figure 1 and the following requirements.

The wall thickness, amount of circular reinforcement, S-stirrup system and concrete strength shall comply with those set out in Table 1 herein. The spacing center to center of adjacent inner rings of circumferential reinforcement in a cage shall not exceed 4 inches for pipe up to and including pipe having a 4-inch wall thickness nor exceed 5 1/2 inches for 54 inch pipe and 6 inches for all other pipe sizes.

Each line of S-stirrups shall have a continuous S shape extending longitudinally from end to end of the pipe. They shall extend from the inner cage toward the outer surface of the pipe for a distance not less than the minimum amplitude. S-stirrups shall pass around and be in contact with each inside circumferential member of the inner cage. Each line of S-stirrups shall lie essentially in a plane passing through the longitudinal axis of the pipe.

Where more than one length of stirrup material is used per line, a lap around one circumferential member of the inner cage shall be made. The ends of "S" shaped stirrups at splices shall include an outer bend. Not more than three lengths of S material may be used in a line, and the minimum length of a section of S-stirrups shall be 30 inches.

All designs in Table 1 are accepted designs with noted 0.01 inch crack and ultimate D-load.

**Additional Markings.** After the capital letter "D" designating the D-load, show the design wall thickness in inches expressed as a decimal. Pipe with "S" stirrups shall have the symbol S. Pipe requiring axis orientation without lift holes, i.e. stirrup pipe, quadrant reinforced pipe, shall have the center line of the crown of the pipe marked inside and outside with the symbol TB. Pipe with quadrant steel shall be marked with the symbol Q. Pipe with deformed wire reinforcement required in the design shall have the symbol DF.

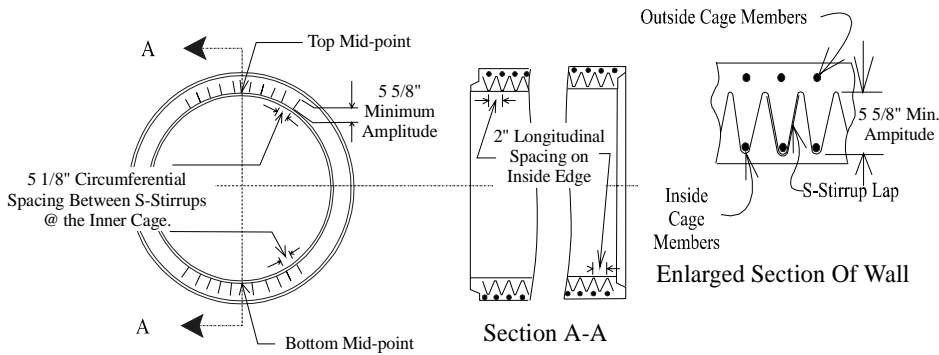

Figure 1.

Illustrative Example of S-Stirrup Support System for 0.01 inch Crack D-load 3,000, 102-inch Dia. Pipe Minimum area Per support 0.053 Sq. In., 11 Lines Spaced @ 5 1/8 inches. For Other Classes and Sizes, See Table 1.

**TABLE 1**  
**0.01 Inch Crack D-Load 3,000**  
**Ultimate Strength D-Load 3,750**

Internal Diameter of Pipe in.	Wall Thickness in.	Circular Reinforcement in Circular Pipe		"S" Stirrups				
		Inner Cage sq. in./ft. of pipe	Outer Cage sq. in./ft. of pipe	Minimum Area Per Support Element sq. in.	Number of Lines	Longitudinal Spacing in.	Circumferential Spacing on Inner Cage in.	Minimum Amplitude of Stirrups in.
Concrete Strength 5,000 Psi								
54	5 1/2	0.64	0.48	0.029	15	2	2 1/8	2 5/8
60	6	0.70	0.53	0.029	14	2	5 5/8	3 1/8
66	6 1/2	0.79	0.59	0.029	13	2	3 1/8	3 5/8
72	7	0.87	0.66	0.029	12	2	3 5/8	4 1/8
78	7 1/2	0.92	0.69	0.031	11	2	4 1/8	4 5/8
84	8	0.99	0.74	0.034	11	2	4 5/8	5 1/8
90	8	1.13	0.85	0.041	11	2	4 5/8	5 1/8
96	8 1/2	1.20	0.90	0.045	11	2	5 1/8	5 5/8
102	8 1/2	1.34	1.00	0.053	11	2	5 1/8	5 5/8
108	9	1.51	1.13	0.063	11	2	5 5/8	6 1/8
114	9 1/2	1.51	1.13	0.064	11	2	6 1/8	6 5/8
120	10	1.62	1.21	0.068	11	2	6 1/2	7 1/8
126	10 1/2	1.73	1.30	0.072	11	2	6 7/8	7 5/8
132	11	1.84	1.38	0.076	11	2	7 1/4	8 1/8
144	12	2.09	1.57	0.085	11	2	8	9 1/8

\* Number of lines in the table indicates the number of longitudinal lines required in each top and bottom portion of the pipe. The area of each support element in the pipe is 2 times the cross-sectional area of the "S" stirrups wire used. There shall be an equal number of these lines of "S" stirrups on either side of the mid-point of both the top and bottom of the pipe. See Fig. 1.

\*\* The amplitude is the overall width of the line of stirrups.



**S-708.03--Concrete Cattlepasses.** Concrete cattlepasses shall conform to the plans, the applicable requirements of S-708.02, and the following: The requirements as to manufacture, materials, and curing shall conform to the requirements of AASHTO Designation: M 170. The compressive strength of the concrete shall be at least 4000 psi at 28 days.

**S-708.04--Reinforced Concrete Flared-End Section.** Reinforced concrete flared-end sections shall conform to the plans, the applicable requirements of S-708.02 and the following: The requirements as to manufacturer, materials, and curing shall be the same as for the connecting pipe. The compressive strength of the concrete shall be at least 3000 psi at 28 days.

**S-708.05--Perforated Concrete Pipe.** Perforated concrete pipe shall conform to the requirements of S-708.02.4 and AASHTO Designation: M 175.

**S-708.06--Concrete Drain Tile.** Standard drain tile or extra quality drain tile shall conform to the applicable requirements of AASHTO Designation: M 178.

**S-708.07--Porous Concrete Pipe for Underdrains.** Porous concrete pipe for underdrains shall conform to the requirements of AASHTO Designation: M 176.

**S-708.08 thru S-708.13--Blank.**

**S-708.14--Reinforced Concrete Arch Pipe.** Reinforced concrete arch pipe shall meet the requirements of AASHTO Designation: M 206. Horizontal elliptical pipe may be furnished in lieu of arch pipe.

**S-708.15--Reinforced Concrete Elliptical Culvert, Storm Drain, and Sewer Pipe.** This pipe shall conform to the requirements of AASHTO Designation: M 207.

**S-708.16--Joints for Circular Concrete Sewer and Culvert Pipe, Using Rubber Gaskets.** The joints shall conform to the requirements of AASHTO Designation: M 198.

**S-708.17--Corrugated Plastic Pipe Culverts.**

**S-708.17.1--Corrugated Polyethylene Pipe Culverts.** Corrugated polyethylene pipe shall conform to the requirements of AASHTO Designation: M 294, Type S.

The Contractor shall furnish to the Engineer three copies of the manufacturer's certified test reports and certification covering each shipment of pipe stating the amount furnished and that the pipe, fittings, couplings, etc. comply with the requirements of the specifications. Certifications and certified test reports for compliance with this specification shall be performed by an approved third-party testing source.

**S-708.17.2--Corrugated Poly (Vinyl Chloride) (PVC) Pipe Culverts.** Corrugated poly (vinyl chloride) (PVC) pipe shall conform to the requirements of ASTM Designation: F 949.

The Contractor shall furnish to the Engineer three copies of the manufacturer's certified test reports and certification covering each shipment of pipe stating the amount furnished and that the pipe, fittings, etc. comply with the requirements of the specifications.

**S-708.18--Sewer Pipe Used for Underdrains.**

**S-708.18.1--General.** Pipe less than four inches in diameter shall conform to commercial grade PVC water pipe.

Perforations, when required, shall be circular and conform to the requirements of AASHTO Designation: M 278.

**S-708.18.2--Acrylonitrile-Butadiene-Styrene (ABS) Sewer Pipe.** This pipe and fittings used for underdrains shall meet the requirements of ASTM Designation: D 2751 for the pipe SDR number specified.

**S-708.18.3--Type PSM Poly (Vinyl Chloride) (PVC) Sewer Pipe.** This pipe and fittings used for underdrains shall meet the requirements of ASTM Designation: D 3034 for the pipe SDR number specified.

**S-708.18.4--Poly (Vinyl Chloride) (PVC) Corrugated Sewer Pipe.** This pipe with a smooth interior and fittings shall conform to the requirements of ASTM Designation: F 949. The pipe is for use in non-pressure drainage applications as an alternate to ABS and PVC sewer pipe when the SDR number is specified as 35 or greater.

**S-708.19--Corrugated Polyethylene Drainage Tubing.** This tubing used for underdrains shall meet the requirements of AASHTO Designation: M 252, Type S and/or Type SP, as applicable.

**S-708.20--Perforated Semicircular Plastic Pipe for Underdrains.**

**S-708.20.1--General.** Semicircular plastic subdrain pipe is intended for direct burial and shall be extruded from thermoplastic materials as specified below. Unless otherwise specified, the pipe shall be supplied in 20-foot lengths. The pipe shall have an expanded bell on one end for direct coupling, or separate couplings shall be supplied. The pipe sections shall be joined by a friction fit.

The pipe fittings including straight couplings, end caps, tees, right laterals, left laterals, 45° elbows, and 90° elbows shall be molded from thermoplastic materials as specified below. Fabricated fittings shall be made of the same material as the pipe sections.

**S-708.20.2--Pipe Sections and Fabricated Fittings.** The pipe sections and fabricated fittings shall be made from virgin poly vinyl chloride (PVC). PVC resins shall conform to ASTM Designation: D 1784, Class 12454-B. Virgin resin is defined as resin which contains not more than 10 percent regrind material and has not previously been used to make another product.

**S-708.20.3--Molded Fittings.** Molded fittings shall be made from virgin high density polyethylene (HDPE) conforming to ASTM Designation: D 1248, Type III, Class B, Category 3; with the addition of a minimum of 0.25% carbon black.

**S-708.20.4--Workmanship.** The plastic pipe and fittings shall be homogeneous throughout and free of visible surface flaking, chips or cracks. The semicircular trough interior shall be smooth and free from obstructions. The products shall be as uniform as commercially practicable in respect to color, opacity, density and other physical properties.

**S-708.20.5--Dimensions.** The minimum wall thickness of the pipe at any point shall be 0.125 inch, protective lip excluded. Sufficient additional wall thickness shall be supplied at perforated areas to maintain an effective wall strength equal to 0.125 inch thick nonperforated wall. The protective lip shall extend a minimum of 0.500 inch from the pipe at an angle of approximately 30°. The nominal inside radius of the semicircular trough shall be 2 5/16 inch, providing a minimum cross-sectional flow area of 8.3 square inch below the water entry level. Total water intake area shall be 3.5 square inch per linear foot. All measurements shall be taken at 72 ± 5°F.

**S-708.20.6--Load Deformation.** At a deflection of 0.2 inch, the minimum pipe stiffness,  $F\Delta y$ , shall be 100 psi when tested in accordance with ASTM Designation: D 2412, except that specimens shall be conditioned a minimum of 12 hours at approximately 72°F.

**S-708.20.7--Impact Resistance.** Impact resistance of the plastic pipe and fittings shall be as follows when tested in accordance with ASTM Designation: D 2444, except that specimens for routine inspection shall be conditioned for a minimum of one hour at approximately 72°F or two hours at approximately 32°F.

Using a 20-pound Tup B, the plastic pipe and fittings shall be capable of withstanding 125 foot-pounds at 72°F and 62 foot-pounds at 32°F.

**S-708.20.8--Hydrocarbon Resistance.** The plastic pipe and fittings shall meet the load deformation requirements specified above after being immersed for seven days in normal heptane as specified in ASTM Designation: D 543.

**S-708.20.9--Product Marking.** Each section of pipe and each fitting shall be clearly marked on the exterior surface to show the manufacturer's name or trademark and the material from which it is made, PVC or HDPE. Product marking shall be permanent and legible in characters at least 3/8 inch high.

**S-708.20.10--Packing and Storage.** All pipe sections and fittings shall be so stored prior to shipment that they do not warp, deteriorate or suffer dimensional distortion.

All pipe sections shall be banded or palletized so as to protect them during shipment, handling and subsequent storage. Fittings shall be banded together or packed in suitable containers.

**S-708.21--Blank.**

**S-708.22--Precast Concrete Box Culvert.**

**S-708.22.1--General.** Precast concrete box culverts shall conform to the design and dimensions shown on the plans, and the materials and manufacture of box sections shall meet the requirements of AASHTO Designation: M 259 or M 273, as applicable, with the following exceptions:

**S-708.22.2--Exceptions to AASHTO.**

Cement shall meet the requirements of S-701.

Aggregates shall meet the requirements of S-703.02 and S-703.03, except that gradation will not apply.

Admixtures and blends may be used with the approval of the Engineer.

Reinforcement shall meet the requirements of S-711.02.3.

Water shall meet the requirements of S-714.01.

A lot will consist of a group of 15 box sections of a single size or fraction thereof; or all units produced in one calendar week, Sunday through Saturday, whichever comes first.

Each line of box section should be manufactured by one producer's plant.

The slab and wall thickness shall not vary from the design dimensions by more than five percent or 3/16 inch, whichever is greater.

The depth of cover and amount of steel may, at the discretion of the MDOT Testing Engineer, be checked by an electro magnetic device.

The permissible variation in diameter of any wire in finished fabric shall conform to the tolerances prescribed for the wire before fabrication by AASHTO Designation: M 32.

Box sections may be repaired, if necessary, because of occasional imperfections in manufacture or handling damage and will be acceptable if, in the opinion of the Engineer, the repairs are sound, properly finished, and cured and the repaired box section conforms to the specifications. These repairs will be allowed in the ends and on joints, only. No repairs will be allowed in the barrel of the box section.

**S-708.23--Special Sections.** Any special section, not otherwise specified, shall be of the same wall thickness, size, and type as the pipe to which it is joined and shall conform to the applicable requirements for the particular type of pipe as set forth therein.

Elbows, tees, wyes, or other such special sections shall, unless otherwise specified, have a minimum length for each projection sufficient to properly join the section to the joining elements of the completed structure.

Other details shall be as shown on the plans.

## **SECTION S-709 - METAL PIPE**

**S-709.01--Cast Iron Culvert Pipe.** Cast iron culvert pipe shall conform to ASTM Designation: A 716, for the wall thicknesses set out in the Tables, or as specified on the plans.

**S-709.02--Corrugated Metal Culvert Pipe and Pipe Arches.** All corrugated metal pipe and arches covered in these specifications shall conform to AASHTO Designation: M 36, except the minimum gauge thickness shall be as shown on the plans or in the special provisions; however, corrugated metal pipe manufactured from sheets thicker than that specified will be acceptable when approved by the Engineer. The internal diameter of corrugated metal pipe will be determined by inside measurement between the crests of the corrugations. Corrugations greater than 3" x 1" will not be allowed in arch pipe.

### **S-709.03--Bituminous Coated Corrugated Metal Pipe and Pipe Arches.**

**S-709.03.1--Materials.** Bituminous coated corrugated metal pipe and arches shall conform to all the requirements of S-709.02 and, in addition, shall be completely coated inside and out with an asphalt cement which will meet the performance requirements hereinafter set forth.

The pipe shall be coated uniformly to a minimum thickness of 0.05 inch, measured on the crest of the corrugations. The asphalt cement used shall be at least 99.5% soluble in carbon disulfide.

**S-709.03.2--Performance Requirements.** The asphalt cement shall adhere to the metal tenaciously, shall not chip off in handling, and shall protect the pipe from deterioration as evidenced by successfully withstanding the following tests.

**S-709.03.2.1--Stability Tests.** Parallel lines shall be drawn along the valleys of the corrugations of a representative sample of coated pipe and the specimen placed on end in a constant-temperature oven with the parallel lines in a horizontal position.

The temperature of the specimen shall be maintained at a temperature of 150°F ( $\pm 2^\circ\text{F}$ ) for a period of four hours. At the end of this time, no part of any line shall have dropped more than 1/4 inch.

**S-709.03.2.2--Imperviousness Test.** The asphalt cement shall be impervious to liquids as indicated by the following tests; 25 to 50 ml of a 25% water solution of sulfuric acid and of a 25% water solution of sodium hydroxide shall be placed in separate corrugations for a period of 48 hours, during which time no loosening or separation of the bituminous material from the metal shall have taken place.

**S-709.04--Bituminous Coated Paved Invert Corrugated Metal Pipe and Arches.**

Bituminous coated corrugated metal pipe and arches with paved invert shall conform in every respect to the requirements of S-709.03 and the requirements set out below.

Bituminous material shall be applied in such a manner that a smooth pavement will result in the invert (bottom of pipe when installed) for 1/4 of the circumference of circular pipe and 40% of the circumference of pipe arches. The pavement, except where the upper edges intersect the corrugations, shall have a minimum thickness of 1/8 inch above the crest of the corrugations.

**S-709.05--Polymer Coated Corrugated Metal Pipe and Pipe Arches.** Polymer coated corrugated metal pipe and arches shall conform to the requirements of S-709.02 and AASHTO Designation: M 245. The polymer precoated sheet shall be Type B with a minimum coating thickness of 0.010 inches or 0.25 millimeters on both surfaces.

**S-709.06--Corrugated Metal Pipe for Underdrains.** Corrugated metal pipe shall conform to AASHTO Designation: M 36.

**S-709.07--Bituminous Coated Corrugated Metal Pipe for Underdrains.** Bituminous coated corrugated metal pipe shall be pipe conforming to S-709.06 with a bituminous coating applied in accordance with the requirements of S-709.03.

**S-709.08--Polymer Coated Corrugated Metal Pipe for Underdrains.** The metal pipe for underdrains shall conform to the requirements of S-709.06 and the polymer coating shall conform to the requirements of S-709.05.

**S-709.09--Corrugated Aluminum Alloy Culvert Pipe and Arches.** Corrugated aluminum culvert pipe and arches shall conform to the requirements of AASHTO Designation: M 196. Minimum thickness of sheets shall be as indicated on the plans or in the special provisions.

**S-709.10--Corrugated Aluminum Alloy Pipe for Underdrains.** Corrugated aluminum pipe underdrains shall conform to the requirements of AASHTO Designation: M 196.

**S-709.11--Bituminous Coated Corrugated Aluminum Alloy Culvert Pipe and Arches.** Bituminous coated aluminum culvert pipe and arches shall conform to AASHTO Designation: M 196, and in addition shall be coated inside and out as specified in S-709.03.

**S-709.12--Bituminous Coated Paved Invert Corrugated Aluminum Alloy Culvert Pipe and Arches.** Bituminous coated corrugated aluminum culvert pipe and arches with paved invert shall conform in every respect to the requirements of S-709.09 and, in addition, to the requirements of S-709.04 for paved invert.

**S-709.13--Bituminous Coated Corrugated Aluminum Alloy Pipe for Underdrains.**

This pipe shall conform to AASHTO Designation: M 196 and shall be coated with bituminous material conforming to AASHTO Designation: M 190, type coating as specified.

**S-709.14--Structural Plate for Pipe, Pipe Arches, and Arches.** These conduits and bolts and nuts for connecting plates shall conform to AASHTO Designation: M 167.

**S-709.15--Full Bituminous Coated Structural Plate Pipe, Pipe Arches, and Arches.**

These conduits shall conform to AASHTO Designation: M 167 and shall be coated with bituminous material conforming to AASHTO Designation: M 190, type coating as specified.

**S-709.16--Aluminum Alloy Structural Plate for Pipe, Pipe Arches, and Arches.** These conduits and the bolts and nuts for connecting plates shall conform to AASHTO Designation: M 219.

**S-709.17--Full Bituminous Coated Aluminum Alloy Structural Plate Pipe, Pipe Arches and Arches.** These conduits shall conform to AASHTO Designation: M 219 and shall be coated with bituminous material conforming to AASHTO Designation: M 190, type coating as specified.

**S-709.18--Special Sections.** Any special sections, such as elbows, flared end sections, branch connections, or other specified appurtenances shall be of the same base metal, size, type, fabrication, coating, invert, and other applicable requirements as for the particular type of pipe to which it is joined.

Each elbow shall be not less than the following length:

<u>Diameter</u>	<u>Angle - Up to and Including</u>	<u>Minimum Overall Length</u>
6-inch to 48-inch	22 1/2°	24 inches
54-inch to 84-inch	22 1/2°	48 inches
6-inch to 36-inch	45°	24 inches
42-inch to 84-inch	45°	48 inches
6-inch to 24-inch	60°	24 inches
30-inch to 60-inch	60°	48 inches
66-inch to 84-inch	60°	72 inches
6-inch to 15-inch	90°	24 inches
18-inch to 36-inch	90°	48 inches
42-inch to 60-inch	90°	72 inches
66-inch to 84-inch	90°	96 inches

Other details shall be as shown on the plans.



All three-piece corrugated metal end sections shall have 12 gauge minimum thickness sides and 10 gauge minimum thickness center panels. Width of center panels shall be greater than 20 percent of the pipe periphery. Multiple panel bodies shall have lap seams tightly joined by three-eighths inch diameter galvanized rivets or bolts. For 60-inch thru 84-inch sizes, reinforced edges shall be supplemented with galvanized stiffener angles. The angles shall be two inches by two inches by one-quarter inch for 60-inch thru 72-inch diameters and two and one-half inches by two and one-half inches by one-quarter inch for 78-inch and 84-inch diameters. The angles shall be attached by three-eighths inch diameter galvanized nuts and bolts. For the 79-inch by 49-inch and 85-inch by 54-inch sizes, reinforced edges shall be supplemented by galvanized stiffener angles which are two inches by two inches by one-quarter inch. Angle reinforcement shall be placed under the center panel seams on the 79-inch by 49-inch and 85-inch by 54-inch sizes. A toe plate of the same materials as the end section shall be furnished and installed on each end section, unless deemed by the Engineer to be unnecessary for the particular location.

**S-709.19--Steel Pipe and Steel Pipe Encasements.** Steel pipe shall conform to the design and dimensions shown on the plans, and materials shall meet the requirements hereinafter specified.

Steel pipe with a nominal diameter of less than six inches shall meet the requirements of ASTM Designation: A 53, Type E or F, Grade A, Black, Schedule 40.

Steel pipe with nominal diameter of six inches or more shall meet the requirements of ASTM Designation: A 139, Grade A unless otherwise specified, Welded, Black, for the wall thicknesses set out in the Tables, or as specified on the plans.

Steel pipe with a nominal diameter greater than 24 inches shall be as specified on the plans.

Unless otherwise indicated on the plans, steel pipe ends shall be factory beveled for welding. The Contractor shall furnish the Engineer the original and three copies of the Mill Certificate of Compliance for all materials furnished.

## SECTION S-710 - PAINT

### S-710.01--General.

**S-710.01.1--Requirements.** All paint materials, including vehicle, pigment, paste, driers, thinners, and mixed paint shall conform to the requirements of these specifications unless otherwise stipulated. Paint shall be furnished ready-mixed or in paste or powder form, as may be specified, and shall be of the type and color shown on the plans or as otherwise indicated.

All paints for incorporation in the work shall be manufactured in the United States. Acceptance will be based on manufacture's certification. It shall be the responsibility of the Contractor to obtain and furnish the Engineer certification by the manufacturer that all components used in paint comply with this provision and other applicable provisions under the contract with respect to each component. Any paint that has caked, hardened or otherwise deteriorated shall not be used. The Engineer reserves the right to sample and test the paint as per S-710.01.2.

**S-710.01.2--Sampling and Testing.** Sampling and testing of paint shall be in accordance with the appropriate method in Federal Test Method No. 141, ASTM and/or Mississippi Test Method.

The MDOT Central Laboratory may utilize x-ray analysis, gas chromatography, infrared, or ultra violet spectral analysis of the paint or its components to determine whether specified ingredients were used. Paint found not to be in compliance with the approved formula shall not be used.

Each container or label thereon shall be marked as follows:

- Net weight in pounds
- Net volume in U. S. gallons
- Colors
- Code Number
- Batch Number
- Name and percentage of each component
- Name and address of manufacturer
- Date of manufacture

In addition, each container and labeling thereon shall meet the requirements of State and Federal Regulations for transporting the paint.

**S-710.02--Mixed Paints.** Unless otherwise specified, paint shall be delivered completely mixed and ready for use without further additions or alterations. Paint shall be of a uniform consistency and when applied shall dry to a hard tough film without running, streaking or sagging.

All paints and components thereof shall conform to the applicable subsection as contained herein.

Mixed paint in storage shall not be exposed to temperatures less than 32°F, or such higher temperature as recommended by the paint manufacturer. Paint exposed to temperatures lower than specified will be subject to rejection or retesting.

**S-710.02.1-Aluminum Paint.** This paint shall be aluminum alkyd paint as specified by the Steel Structures Painting Council Paint Specifications SSPC 101-64T. Paint that is to be stored for periods longer than six months shall be a two component system. A two component paint shall be prepared by mixing two pounds of aluminum paste with one gallon of vehicle.

Type I Leafing Aluminum Paint shall always be used as the finish or top coat. Intermediate coats shall be alternate coats of Type II Non-Leafing Aluminum Paint and Type I Leafing Aluminum Paint.

**S-710.03--Traffic Paint:**

**S-710.03.1--Materials.**

**S-710.03.2--Binder.** The binder shall consist of a mixture of synthetic resins, at least one of which is solid at room temperature. The total binder content of the paint compound shall be well distributed throughout the compound. The binder shall be free from all foreign objects or ingredients that would cause bleeding, staining or discoloration. The binder shall be 26 percent minimum by weight of the paint compound. The binder shall be characterized by an IR Spectra.

**S-710.03.3--Pigment.** The pigment used for the white paint compound shall be a high-grade pure (minimum 93 percent titanium dioxide TiO<sub>2</sub>). The white pigment content shall not be less than 10 percent by weight and shall be uniformly distributed throughout the paint compound.

The pigments used for the yellow paint compound shall be heat resistant, silica encapsulated lead chromate yellow and moly oranges which shall produce a compound meeting the requirements of FED 595 Color No. 33538. The yellow marking material shall contain a minimum of 4 percent by weight of the yellow pigment with a minimum lead chromate content of 60 percent where Type III drop on glass beads are specified and 50 percent for other drop on glass beads.

**S-710.03.4--Filler.** The filler to be incorporated with the resins and a binder shall be a white calcium carbonate, silica, or an approved substitute. Any filler which is insoluble in 6N hydrochloric acid shall be of such particle size as to pass a No. 100 sieve.

**S-710.03.5--Glass Beads.** Acceptance will be based on manufacture's certification. It shall be the responsibility of the Contractor to obtain and furnish the Engineer certification by the manufacturer that glass beads comply with this specification and any applicable provisions under the contract. The Engineer reserves the right to sample and test the glass beads. Intermix glass beads shall be uniformly mixed throughout the material at the rate of not less than 27 percent by weight (retained on the No.100 sieve) of paint compound. Drop on beads shall be used with pavement markings material and shall be applied uniformly at a minimum rate of 12 pounds per 100 square feet where Type III drop on glass beads are specified and at a rate of 8 pounds per 100 square feet for other drop on glass beads.

**S-710.03.6--Properties.** The drop on glass beads furnished under this specification shall consist essentially of transparent, water-white glass particles of a spherical shape. They shall be manufactured from a glass of a composition designed to be highly resistant to traffic wear and to the effects of weathering. The glass beads shall conform to the following requirements:

(a) **Sieve Analysis.** The glass beads shall meet the following sieve requirements:

(1) Type III Drop On Glass Beads

<u>Sieve No.</u>	<u>% Retained</u>	<u>% Passing</u>
12	0	100
14	0-5	95-100
16	5-20	75-95
18	40-80	10-47
20	10-40	0-7
25	0-5	0-2
Pan	0-2	- -

(2) Other Drop On Beads

<u>Sieve Size</u>	<u>% Passing</u>
No. 16	99-100
No. 20	75-95
No. 30	65-95
No. 50	15-35
No. 100	0-5

- (b) **Imperfections.** The surface of the glass beads shall be free of pits and scratches. The sizes beads shall have a roundness of 70% minimum average (ASTM D 1155) with the exception of the +20 portion, which shall have a 65% minimum true spheres, tested visually.
- (c) **Index of Refraction.** The index of refraction of the glass beads shall be not less than 1.50 when tested by the immersion method at 77°F.
- (d) **Silica Content.** The glass beads shall contain not less than 65 percent silica (SiO<sub>2</sub>).
- (e) **Chemical Stability.** Glass beads which show tendency toward decomposition, including surface etching, when exposed to paint or paint constituents will be rejected. The glass beads shall be tested by Federal Specification T-T-B-1325A, Section 4.3.11 (water resistant soxhlet extraction method) with the following exceptions: Under "Procedure", the size of sample to be tested shall be 25 grams. Under testing, Paragraph (1), the reflux-time shall be 5 hours and upon examination after testing the glass beads shall show no dulling effect. Under Paragraph (2), if more than 4.5 mls of 0.1N hydrochloric acid are used to reach the end point, it shall constitute failure of the test.
- (f) **Flowing Properties.** The glass beads shall flow uniformly through dispensing equipment in atmospheric humidity up to 94%. The drop beads shall pass the following test: One hundred grams of glass beads, spread evenly and thinly in a suitable container, shall be conditioned at 77°F for 4 hours over a solution of sulfuric acid (Sp. Gr. 1.10) in a closed desiccator. After 4 hours, the glass beads shall flow readily through a clean glass analytical funnel, 60°, 5 mm diameter and 105 mm stem. Inside diameter of the stem shall be a nominal 1/4 inch.
- (g) **Coating:** The glass beads used for intermix shall be uncoated. The glass beads used for the drop on application shall be coated with an adhesion promoting coating. Silicone coated drop on beads shall not be allowed.
- (h) **Packaging.** The Drop on glass beads shall be delivered in approved moisture proof bags consisting of at least five-ply paper construction unless otherwise specified. Each bag shall contain 50 or 55 pounds net, and shall be legibly marked with the manufacturer, specifications and type, lot number, and the month and year the glass beads were packaged.

**S-710.03.7--Paint**: In the plastic state, the material shall not give off fumes that are toxic or otherwise injurious to persons or property. The manufacturer shall provide material safety sheets for the product.

The temperature versus viscosity characteristic of the plastic material shall remain constant and the material shall not deteriorate in any manner during reheating processes.

There shall be no obvious change in color of the material as a result of repeated heating or from batch to batch. The maximum elapsed time after application after which normal traffic will leave no impression or imprint on the new stripe shall be 30 seconds when the air and road surface temperature is approximately (68°F ± 6°F). After appreciable deformation or discoloration, shall remain free from tack, and shall not lift from the pavement under normal traffic conditions within a road temperature range of -20° to 150°F. The stripe shall maintain its original dimensions and placement. Cold ductility of the material shall be such as to permit normal dimensional distortion as a result of traffic impact within the temperature range specified.

The material shall provide a stripe that has a uniform thickness throughout its cross section and has the density and character to provide a sharp edge of the line.

The paint compound after heating for 4 hours ± 5 minutes at 375° ± 3°F and cooled to 77°F shall meet the following requirements for daylight reflectance and color, then tested, using a color spectrophotometer with 45° circumferential/0° geometry, illuminate C, and 2° observer angle. The color instrument shall measure the visible spectrum from 380 to 720 nm with a wavelength measurement interval and spectral bandpass of 10 nm.

White: Daylight Reflectance (Y) 75 percent minimum  
 \*Yellow: Daylight Reflectance (Y) 42-59 percent

\*Shall match Federal 595 Color No. 33538 and Chromaticity limits as follows:

x	.470	.510	.485	.530
y	.455	.485	.425	.456

**S-710.03.7.1--Specific Gravity**. The specific gravity of the paint material shall not exceed 1.87.

**S-710.03.7.2--Softening Point**. After heating the paint material for 4 hours ± 5 min. at 375° ± 3°F and testing in accordance with ASTM E 28, the material shall have a minimum softening point of 180°F as measured by the ring and ball method.

**S-710.03.7.3--Tensile Bond Strength.** After heating the paint material for 4 hours  $\pm$  5 min. at 375°F, the tensile bond strength to unprimed, sandblasted portland cement concrete block, 0.0625 inch thick film drawdown at 375°F, tested at 75°  $\pm$  2°F shall exceed 180 psi when tested in accordance with ASTM D 4796-88.

**S-710.03.7.4--Impact Resistance.** After heating the paint material for 4 hours  $\pm$  5 min at 375°  $\pm$  3°F, the impact resistance shall be a minimum of 50 inch pounds with no cracks or bond loss when 0.0625-inch thick film drawdown is made at 375°F on an unprimed sandblasted portland cement concrete block, male indenter 5/8 inch, no female Die, tested at 75°  $\pm$  2°F when tested in accordance with ASTM D 2794 minimum.

**S-710.03.7.5--Yellowness Index.** The white paint material shall not exceed a yellowness index of 12 when tested in accordance with ASTM D 1925.

- (a) **Identification** - Each package of material shall be stenciled with the manufacturer's name, the type of material and specification number, the month and year the material was packaged and lot number. Lot numbers must begin with the last two digits of the year manufactured and be sequential. The letters and numbers used in the stencils shall be a minimum of 1/2 inch in height.
- (b) **Packaging** - Paint material shall be packaged in suitable containers which will not adhere to the product during shipment and storage. The container of paint material shall weigh approximately 50 pounds. Each container shall designate the color, binder (alkyd or hydrocarbon), spray and user information. The label shall warn the user that the material shall be heated in the range of 350° - 425°F.
- (c) **Storage Life** - The material shall meet the requirements of this specification for a period of one year. The paint must also melt uniformly with no evidence of skins or unmelted particles for this one year period. Any material not meeting the above requirements shall be replaced by the manufacturer.

**S-710.04-Inorganic Zinc Rich System:**

**S-710.04.1--Inorganic Zinc Primer.** The shop coat or prime coat shall be a self-curing multiple component inorganic zinc rich primer conforming to the requirements of AASHTO M 300, Type I or Type II. The inorganic zinc rich primer, as applied, shall meet State and Federal regulations on Volatile Organic Compounds (VOC).

The inorganic zinc primer shall be formulated so as to produce a distinct contrast in color with the blast cleaned metal surface and the intermediate field coat to be applied thereon.

The inorganic zinc primer must be one from the Mississippi Department of Transportation's "List of Approved Sources of Materials".

The paint manufacturer's technical representative who is certified by the National Association of Corrosion Engineers (NACE) shall be present at the beginning of coating operations as needed

to provide technical expertise in the application of the coating. This technical expertise shall be provided without additional cost to the Project. The fabricator is responsible for arranging for the presence of the manufacturer's technical representative.

**S-710.04.2--Epoxy Mastic Field Touch-Up Paint.** Inorganic zinc primer coat which has been damaged during storage, handling, transporting and/or erection shall be repaired using epoxy mastic touch-up paint prior to finish coating.

Epoxy mastic touch-up paint shall be manufactured or recommended by the supplier of the inorganic zinc primer, shall be as listed on the Mississippi Department of Transportation's "List of Approved Sources of Materials" and, as applied, shall be VOC compliant with State and Federal Regulations.

The epoxy mastic touch-up paint shall conform to the same formulation as originally approved by the Mississippi Department of Transportation. Determination of conformance to the originally approved formulation will be based on physical tests, x-ray diffraction pattern and infrared spectrum. The results of these tests shall be in agreement with the results obtained on the originally approved formulation.

**S-710.04.3--Acrylic Latex Intermediate and Top Coats (Field Coats).** The acrylic latex field coats shall be manufactured by the supplier of the inorganic zinc primer coat, shall be as listed on the Mississippi Department of Transportation's "List of Approved Sources of Materials" and, as applied, shall be VOC compliant with State and Federal regulations. The acrylic latex paint shall conform to the same formulation as originally approved by MDOT.



Determination of conformance to the originally approved formulation will be based on physical tests and infrared spectrum of the vehicle component. The infrared spectrum (2.5 to 15 microns) of the vehicle component shall agree with the infrared spectrum of the vehicle component of the originally approved paints in both peak position and relative intensity of the peaks.

The color of the acrylic latex intermediate coat shall be white in color. The color of the acrylic latex top coat shall be light gray in color.

At the Engineer's request, the paint manufacturer's technical representative who is certified by the National Association of Corrosion Engineers (NACE) shall be present at the job site at the beginning of each separate coating operation as needed to provide technical expertise in the application of the field coats. This technical expertise shall be provided without additional cost to the Project. The Contractor shall be responsible for arranging for the presence of the manufacturer's technical representative.

**S-710.04.4--Mixing of Paint.** All paint shall be mixed in accordance with the paint manufacturer's printed instructions.

**S-710.04.5--Packaging and Marking.** Multiple component paints shall be furnished in premeasured packages so as to form one unit of mixed paint when mixed with the vehicle in its container.

The containers of all paints shall be coated as necessary to prevent attack by the paint. Each container shall bear a label with the following information shown thereon: name and address of manufacturer, trade mark or trade name, kind of paint, date of manufacture and lot number, mixing instructions and equipment clean up instructions. The VOC content shall be stated on the label, product data sheet, or Material Safety Data Sheet.

**S-710.04.6--Acceptance Procedure.** Prior to use, the Contractor must furnish the County Engineer a certificate from the manufacturer, covering each lot of paint in the shipment, attesting that the paint in the shipment conforms to the same formula as that originally approved by the Mississippi Department of Transportation.

Final acceptance of the paint will be based on results of tests performed by the Central Laboratory of the Mississippi Department of Transportation on samples obtained by the County Engineer's representative prior to or after delivery. The use of any lot of paint prior to its final acceptance shall be prohibited.

**S-710.05--Epoxy Mastic System.** The coating system shall consist of modified epoxy mastic prime coat with a uniform dry film thickness of not less than 5 mil nor more than 8 mil and a vinyl finish coat of not less than 3mil nor more than 5 mil.

**S-710.05.1--Prime Coat.** The prime coat shall be a two-component epoxy mastic designed as a one-coat high build complete protective coating system with excellent adhesion to rusted steel and old coating systems after such surfaces have been cleaned as specified.

**S-710.05.1.1--Pigment.** The silica and metallic aluminum pigment shall include rust inhibitors and adhesion reinforcers/promoters. The aluminum factor shall contain both leafing and nonleafing types.

**S-710.05.1.2--Vehicle.** The vehicle shall be a modified epoxy-polymide resin formulated to have suitable insensitivity to moisture and shall contain special wetting agents to insure adequate adhesion.

**S-710.05.1.3--Mixed Paint.** The mixed paint shall conform to the following requirements:

The catalyzed epoxy shall contain  $92\% \pm 2\%$  solids by weight when tested in accordance with ASTM Designation: D 1644 (modified to a drying time of 72 hours at 100°F).

Total solids by volume shall be a minimum of 90%.

The coating shall air cure to a hard, tough film within five days at a temperature of 75°F. It shall be dry to the touch in 24 hours at 75°F.

The usable pot life of the mixed paint shall be not less than four hours at 75°F and two hours at 90°F.

It shall exhibit good compatibility with inorganic zinc primers.

The color shall contrast with the steel and the finish coat.

The catalyzed mixture, after thinning 20% by volume with specified thinner, shall be suitable for spraying in one coat to a 10 mil wet thickness without exhibiting runs or sags.

The coating shall be suitable for application with both conventional and airless spray equipment.

**S-710.05.1.4--Packaged Qualities.** The paint shall be supplied as a two-package material with a one-to-one mixing ratio and shall be well ground and not caked, skinned or badly settled in the container. Usable shelf life shall be not less than 12 months.

**S-710.05.1.5--Flexibility Test.** Apply a five mil dry film thickness of paint to one side of a 4" x 30" x 1/8" steel panel which has been cleaned in accordance with Steel Structures Painting Council SSPC-SP-5, Commercial Blast Cleaning. After the coating has been cured for two weeks at 75°F, it shall show no signs of cracking or loss of adhesion after the panel is uniformly bent 180° degrees (coated side out) around an eight inch diameter pin.

**S-710.05.1.6--Resistance Tests.** The panel (3" x 5" x 1/8") meeting the requirements of ASTM Designation: D 609 shall be prepared by blast cleaning in accordance with SSPC-SP-6, Commercial Blast Cleaning.

After cleaning, the panels shall be exposed to the weather for 30 days to allow uniform rusting. The panels shall then be hand-cleaned with a wire brush in accordance with SSPC-SP-2.

The modified epoxy mastic paint shall be spray applied in one coat to the prepared panels with a uniform dry film thickness of six mils. Curing shall be in accordance with manufacturer's recommendations.

Each test shall be performed on one or more panels, and the paint will be unacceptable if it fails one or more of the following tests:

- (1) Salt Water Resistance. One or more panels shall be scribed with an X of at least two-inch legs down to the base metal and immersed in 5% sodium chloride at  $75 \pm 5^\circ\text{F}$ . The panel(s) shall be examined after 7, 14 and 30 days and shall show neither rusting, blistering, nor softening of the coating beyond 1/16 inch from the scribe mark. The solution shall be changed after each examining period.
- (2) Weathering resistance. One or more panels shall be tested in accordance with ASTM Designation: G 23, Type D. The panel(s) shall be placed on test at the beginning of the wet cycle. After 1,000 hours continuous exposure, the coating shall show neither rusting, blistering, nor loss of bond.

- (3) Salt Fog Resistance. One or more panels shall be scribed with a X of at least two-inch legs down to the base metal. The panel(s) shall then be tested in accordance with ASTM Designation: B 117. After 1,000 hours continuous exposure, the coating shall show neither loss of bond, rusting nor blistering beyond 1/16" from the scribe mark.

**S-710.05.2--Vinyl Finish Coat (Field Coat).** The vinyl finish coat shall be manufactured by the supplier of the prime coat. The vehicle shall consist essentially of vinyl chloride-acetate copolymer resin dissolved in aromatic or ketone and aromatic solvents. The vinyl coat shall display compatibility with, and adhesion to, the cured primer film when applied in accordance with the manufacturer's printed instructions.

**S-710.05.2.1--Composition.**

- (a) The vinyl finish coat shall be gray in color and supplied in a single package at a consistency ready for use. It shall be well grounded and not caked, livered, skinned or badly settled in the container.
- (b) The vinyl finish coat shall contain not less than 29% pigment (by weight) and 19% vehicle (by weight) for a total of no less than 48% solids by weight. The weight per gallon shall be  $9.6 \pm 0.5$  pounds at 77°F. The grind minimum shall be four. Any extender pigments shall be barytes.
- (c) The vinyl finish coat shall air dry at temperatures of 70°F or above to a hard tough film within four hours, entirely by evaporation of solvents. It shall be dry-to-touch in 25 minutes at 70°F.

**S-710.05.3--Packaging.** Two-component paint shall be packaged so that one unit of pigment can be mixed with the vehicle in its container. The containers for all paints shall be coated as necessary to prevent attack by the paint.

Each container shall be plainly marked with the net weight in pounds, net volume in U. S. gallons, color, code number, batch number(s), the name and address of the manufacturer and the date of manufacture. Each container, or label thereon, shall bear a true statement of the name and percentage of each component or constituent, both solid and liquid. Any package not so marked will be unacceptable.

Each shipment of paint shall be accompanied by complete written instructions and precautions for use, either on the container label or in a separate document.

**S-710.05.4--Acceptance Procedure.** Before each shipment is used, the Contractor must furnish the Engineer a certificate from the manufacturer attesting that the commercial product furnished conforms to the same formula as that previously approved by MDOT.

If deemed necessary, final acceptance will be based on results of tests performed on samples obtained by the Engineer prior to or after delivery. Batches of paint found not to be of the approved formulation will be rejected.

**S-710.06--Primer for Miscellaneous Metals.** The primer shall be a commercial product formulated primarily for industrial use, to combine weather durability, resistance to mildly corrosive exposures, with good film build and ease of application with all generally used methods.

## **SECTION S-711 - REINFORCEMENT AND WIRE ROPE**

**S-711.01--Reinforcing Steel and Wire Rope. General.** All reinforcement used in concrete construction, unless otherwise stipulated, shall conform to the provisions and requirements hereinafter set out. The materials when incorporated into the work shall be reasonably free from dirt, paint, oil, grease, loose-thick rust, or other foreign substances and when deemed necessary, shall be cleaned to the satisfaction of the Engineer. Tight-thin rust or powdering rust on these materials shall not be cause to require cleaning. Reinforcement which has rusted sufficiently to cause it to fail to meet specified physical properties or prestressing strands displaying pits visible to the naked eye shall be rejected.

### **S-711.02--Reinforcing Steel.**

**S-711.02.1--Bar Reinforcement.** Bar reinforcement shall conform to the requirements of AASHTO Designation: M 31, Grade 60, for billet steel bars.

Bars shall be fabricated as indicated on the plans; shall be cold-bent, unless otherwise permitted, to the shapes shown on the plans or as directed; and shall be bent prior to being wholly or partially embedded in concrete.

Unless otherwise authorized or provided on the plans, bends or hooks shall not be fabricated to a smaller diameter than that indicated for the bend test. Rail steel bars shall be bent to the specified shapes at the mill or fabricating plant.

The areas and weights to be used in calculations for the various size reinforcing bars shall be as follows:

**STANDARD REINFORCING BARS**

* Bar Numbers	Weight (Lbs./Foot)	Nominal Dimensions-Round Sections		
		Diameter (Inches)	Cross-Sectional Area (Sq. Inches)	Perimeter (Inches)
2 (1)	0.167	0.250	0.05	0.786
3	0.376	0.375	0.11	1.178
4	0.668	0.500	0.20	1.571
5	1.043	0.625	0.31	1.963
6	1.502	0.750	0.44	2.356
7	2.044	0.875	0.60	2.749
8	2.670	1.000	0.79	3.142
9 (2)	3.400	1.128	1.00	3.544
10 (2)	4.303	1.270	1.27	3.990
11 (2)	5.313	1.410	1.56	4.430
14	7.65	1.693	2.25	5.32
18	13.60	2.257	4.00	7.09

\* The bar numbers are based on the number of 1/8 inch increments in the nominal diameter of the bar, except as noted in (2) below.

- (1) No. 2 bars in plain rounds only
- (2) Nos. 9, 10, and 11 are round bars and equivalent in weight and nominal cross-sectional area to the old type 1 inch, 1 1/8 inch, and 1 1/4 inch square bars, respectively.

**S-711.02.2--Bar Mats.** Bar mats for concrete pavement reinforcement shall be Grade 60 billet steel, AASHTO Designation: M 31, and shall conform to the requirements of AASHTO Designation: M 54.

**S-711.02.3--Steel Wire Fabric.** Steel wire fabric shall conform to the requirements of AASHTO Designation: M 55, or AASHTO Designation: M 221.

**S-711.02.4--Dowel Bars and Marginal Bars.** Unless otherwise indicated, dowel bars used to span transverse joints and marginal bars shall be plain round bars. They shall be Grade 60 billet steel, AASHTO Designation: M 31.

Before installation, each dowel bar shall be painted with one coat of industrial grade zinc base primer, epoxy or other approved rust inhibitive primer. One half of each dowel bar shall be greased with a heavy grease equivalent to 600W or cup grease to prevent bonding with concrete. The greased end is to be inserted into the dowel bar sleeve described in the following paragraph.

Sleeves for dowel bars shall be metal or plastic of an approved design, mortar-tight, of sufficient strength to prevent collapse, and at least two inches in length. A suitable stop shall be provided in the sleeve to permit movement of the dowel bar within the sleeve of not less than the thickness of the expansion filler used.

Dowel bars shall be free from burring or other deformations restricting slippage in the concrete.

**S-711.02.5--Tie Bars.** Unless otherwise indicated, tie bars used to span longitudinal joints shall be deformed bars, billet steel, meeting the requirements set forth in S-711.02.1.

**S-711.02.6--Cold-Drawn Steel Wire.** Cold-drawn steel wire shall conform to the requirements of AASHTO Designation: M 32.

**S-711.02.7--Supports for Bar Reinforcement.** Metal bar supports shall be fabricated from stainless steel wire conforming to ASTM Designation: A 493, 16% chromium minimum, or cold-drawn wire with a minimum of 1/2 inch of the height of the leg above the form surface protected by one of the following:

- Plastic coating conforming to CRSI Standards.
- Galvanized, conforming to ASTM Designation: A 153, Class D.
- Stainless steel conforming to ASTM Designation: A 493, 16% chromium minimum.
- Other protective coating as approved by the Engineer.
- Other supports as approved by the Engineer may be used.



**S-711.02.8--Epoxy Coated Reinforcing Bars.** All reinforcement to be epoxy coated shall conform to the requirements of S-711, or as specified on the plans. The epoxy coat shall be in accordance with ASTM Designation: A 775. The Contractor shall furnish written certification that the coated reinforcing bars were cleaned, coated and tested in accordance with the specifications and ASTM Designation: A 775.

**S-711.03--Reinforcement for Prestressed Concrete.**

**S-711.03.1--Pretensioning Reinforcing.**

**S-711.03.1.1--Uncoated Seven-Wire Stress Relieved Strand for Prestressed Concrete.**

Uncoated seven-wire stress-relieved strand for prestressed concrete shall conform to the requirements of AASHTO Designation: M 203.

**S-711.03.1.2--Uncoated Stress-Relieved Wire for Prestressed Concrete.**

Uncoated stress-relieved wire for prestressed concrete shall conform to the requirements of AASHTO Designation: M 204.

**S-711.03.2--Posttensioning Reinforcing.**

**S-711.03.2.1--Bars.** Bars for posttensioning shall be of high tensile strength steel. They shall be equipped with wedge-type anchorages which will develop the minimum specified ultimate bar stress on the nominal bar area.

The minimum physical properties of the bar steel, and of the stress-strain curve determined by static tensile tests, shall conform to the following:

Stress at 0.3% elongation, psi .....	75,000
Stress at 0.7% elongation, psi .....	130,000
Ultimate stress, psi .....	145,000
Elongation in 20 diameters, % .....	4
Modulus of elasticity, psi .....	25,000,000

The diameter tolerance of the bar steel shall be from -0.01 to +0.02375 inch.

**S-711.03.2.2--Parallel Wire Assemblies.** Wire assemblies for posttensioning shall consist of parallel wires of the number and size shown on the plans. Wires shall conform to the requirements of AASHTO Designation: M 204. Minimum ultimate strength requirements for various sizes shall be as follows:

<u>Diameter</u> (inches)	<u>Minimum Ultimate Strength</u> (psi)
0.177	255,000
0.192	251,000
0.225	245,000
0.250	240,000
0.276	236,000

The stress-strain curve for wires shall show the following minimum characteristics, based on the minimum ultimate strength requirements:

Proportional limit (0.01% offset from tangent), % .....	55
Yield point (0.2% offset from tangent), % .....	80
Elongation at rupture .....	4% in 10 inches

The diameter tolerance of wires shall be  $\pm 0.002$  inch.

**S-711.03.3--Anchorages for Post-Tensioned Tendons.**

**S-711.03.3.1--For Bars.** Wedge-type anchorages shall be used for bars. The wedge device shall develop the minimum ultimate strength specified for the nominal bar area.

Wedge anchorages shall bear against anchor plates fabricated of hot-rolled steel having physical characteristics not less than that specified for No. 104 of American Iron and Steel Institute (AISI) Specifications.

**S-711.03.3.2--For Parallel Wire Assemblies.** Wedge or direct-bearing type anchorage shall be used, generally. The anchorage device shall be capable of developing the ultimate strength of the total number of wires anchored. Conical type anchorages shall be embedded within the ends of the concrete members unless otherwise specified. Anchorages shall generally bear against grids of reinforcing steel of approved type.

**S-711.03.3.3--Alternate Anchorage Types.** Alternate anchorage types conforming to the general physical requirements for wedge or direct-bearing type anchorages will be permitted. All anchorage types shall develop the specified ultimate strength of the reinforcing tendons, or the allowable stress of the tendon will be based on the anchorage strength.

As a specified exception, threaded anchorages not on upset or oversize reinforcing ends will not be considered for approval.

Any alternate type anchorage, before being considered, will be required to show evidence of being capable of withstanding at least 3,000,000 cycles of twice the maximum live load stress variation.

**S-711.03.4--Tests for Prestressing Reinforcing.** The Engineer shall be furnished with three certified copies of test results for all tests specified below. These tests shall be performed by the manufacturer or a recognized commercial laboratory at no additional cost to the Project. The Engineer or his representative shall have the privilege of witnessing any or all tests.

**S-711.03.4.1--Strand.** The physical characteristics of strand shall be determined in accordance with AASHTO Designation: M 203.

**S-711.03.4.2--Bars.**

**S-711.03.4.2.1--Proof Test.** During manufacture, each bar shall be proof tested to a minimum stress of 130,000 psi.

**S-711.03.4.2.2--Static Test.** From each mill heat, one static test shall be made on an assembled bar and anchorage to determine the physical properties of the steel and the assembly. Such physical properties shall conform to the minimum physical properties hereinbefore specified.

**S-711.03.4.3--Wires and Wire Anchorages.** One static test shall have been made from each five coils received, except that at least one static test shall have been made for each shipment. For each 500 anchorages received, or fraction thereof, one anchorage assembly shall have been tested statically to destruction.

## SECTION S-712 - GUARDRAIL

### S-712.01--Guardrail Posts.

**S-712.01.1--General.** Unless otherwise specified, guardrail posts may be either wood or steel. All materials for guardrail posts shall conform to the dimensions and requirements as shown on the plans or as set out in these specifications.

**S-712.01.2--Treated Wood Posts.** Treated wood posts shall conform to the size and dimensions as shown on the plans and as hereinafter specified. They shall be inspected in accordance with S-718 except that the posts may be rough and shall be within  $\pm 3/8$ " of the dimensions shown on the plans. Treatment will be in accordance with AWPA Standard C 14.

**S-712.01.3--Steel Posts.** Steel posts shall be of the section and length as shown on the plans and shall conform to the requirements of ASTM Designation: A 36.

The posts may be galvanized or shop painted as specified.

**S-712.02--Metal Rail.** Metal rail for guardrail shall conform to the requirements of AASHTO Designation: M 180 and as specified on the plans.

**S-712.03--Guardrail Hardware.** Guardrail hardware such as bolts, nuts and washers shall conform to the requirements of ASTM Designation: A 307 except specified bolts, as shown on the plans, shall meet the requirements of ASTM Designation: A 325 (AASHTO Designation: M 164). Galvanizing may be hot-dipped or by a mechanical method all in accordance with ASTM Designation: A 153 except for method of coating.

**S-712.04--Guardrail Cable and Anchorage.** Cable shall meet the requirements of AASHTO Designation: M 30 for Type II wire rope.

The anchor rod shall be fabricated of steel conforming to the requirements of ASTM Designation: A 36. The eye may be drop forged or formed with a full penetration weld and shall develop 100 percent of the rod strength.

The swaged fitting and stud assembly shall be of steel conforming to the requirements of ASTM Designation: A 576, Grade 1035 and shall be annealed and suitable for cold swaging. The fitting shall be galvanized in accordance with ASTM Designation: A 123 before swaging. The studs shall conform to the requirements of ASTM Designation: A 449 and shall be galvanized as set forth for guardrail hardware. The swaged fitting, stud and nut shall develop the breaking strength of the wire rope. Three certified copies of the manufacturer's certificate attesting to the strength of the swage fittings shall be furnished the Engineer.

## **SECTION S-713 - CONCRETE CURING MATERIALS AND ADMIXTURES**

**S-713.01--Curing Materials.** Concrete curing agents (including water and earth) shall be free of any ingredients which may damage or be detrimental to the concrete. Such agents, unless otherwise specified, shall conform to the requirements hereinafter set forth.

**S-713.01.1--Burlap Cloth.** Burlap to be used for curing concrete shall conform to the requirements of AASHTO Designation: M 182.

Class 3 burlap shall be used (one or two layers as required) except that substitutions of other classes may be made, provided their combined weight will equal or exceed the weight required.

**S-713.01.2--Liquid Membrane Compound.** Membrane-forming compound for curing concrete shall conform to the requirements of AASHTO Designation: M 148.

Unless otherwise specified, only Type 2 (White Pigmented) will be permitted for use.

The use of liquid membrane for curing concrete surfaces which are to have a rubbed finish or faces of construction joints will not be permitted.

**S-713.01.3--Polyethylene Sheeting (White).** White polyethylene sheeting shall conform to the requirements of AASHTO Designation: M 171 for white opaque polyethylene film.

**S-713.02--Admixtures for Concrete.** Air-entraining admixtures used in portland cement concrete shall comply with AASHTO Designation: M 154. Set-retarding, accelerating, and/or water reducing admixtures shall comply with AASHTO Designation: M 194.

In order to obtain approval of an admixture, the MDOT Materials Engineer shall have been furnished certified test reports, made by an acceptable independent laboratory regularly inspected by the Cement and Concrete Reference Laboratory of the National Bureau of Standards, which show that the admixture meets all the requirements of the applicable AASHTO Standard Specification.

The Engineer reserves the right to sample, for check tests, any shipment or lot of admixture delivered to a project.

The Engineer reserves the right to require tests of the material to be furnished, using the specific cement and aggregates proposed for use on the project, as suggested in AASHTO Designation: M 154 and outlined in AASHTO Designation: M 194.

After an admixture has been approved, the Contractor shall submit to the MDOT Materials Engineer, with each new lot of material shipped, a notarized certification from the manufacturer showing that the material is of the same composition as that originally approved, and that the material has not been in any way changed or altered.

Admixtures containing chlorides will not be permitted.

Failure to maintain compliance with any requirement of these specifications shall be cause for rejection of any previously approved source or brand of admixture.

When an admixture is used in portland cement concrete, it shall be the responsibility of the Contractor to produce satisfactory results.

**SECTION S-714 - MISCELLANEOUS MATERIALS**

**S-714.01--Water.**

**S-714.01.1--General.** All water used shall be free from injurious quantities of oil, acid, alkali, or vegetable matter; shall be reasonably clear; and shall not be brackish. If at any time water from source becomes of unsatisfactory quality or of insufficient quantity, the Contractor shall provide satisfactory water from some other source. Where the source of water is relatively shallow, the Engineer may require the intake to be so enclosed as to exclude silt, mud, grass, or other foreign materials.

Requirements for impurities set out in these specifications are general maximums which may be used as a basis for acceptance. However, if the preliminary analysis indicates that any of the specified limits for acidity or alkalinity, organic solids, or inorganic solids are exceeded, the water may be further tested as provided in S-714.01.6 to determine its suitability for the purpose intended.

**S-714.01.2--Water for Use in Concrete.** Water used in mixing of concrete, mortar, and grout shall be as set out above. In addition, the water shall not contain impurities in excess of the following limits:

Acidity or alkalinity	
(calculated in terms of calcium carbonate), %	0.05
Total organic solids, %	0.05
Total inorganic solids, %	0.05

The tests for organic solids and inorganic solids may be waived by the MDOT Materials Engineer on water samples from ponds, lakes, streams, rivers, and ditches in all except the following counties: Pearl River, Stone, George, Hancock, Harrison and Jackson Counties.

**S-714.01.3--Water for Use in Chemically-Stabilized Subbase and Base.** Water used in construction of subbases or bases which contain cement, lime, or other chemical additive shall be as set out in S-714.01.1 and, in addition, shall not contain impurities in excess of the following limits:

Acidity or alkalinity	
(calculated in terms of calcium carbonate), %	0.5
Total organic solids, %	0.05
Total inorganic solids, %	0.20

The tests for organic solids and inorganic solids may be waived by the MDOT Materials Engineer on water samples from ponds, lakes, streams, rivers, and ditches in all except the following counties: Pearl River, Stone, George, Hancock, Harrison and Jackson Counties.

**S-714.01.4--Water for Use in Granular Subbase and Base.** Water for use in granular subbases or bases may be brackish.

**S-714.01.5--Water for Use in the Planting and Establishment of Vegetation.** Water used for planting and establishment of vegetation shall meet the requirements of S-714.01.1 as related to injurious quantities of oil, acid, or alkali and shall not be brackish.

**S-714.01.6--Tests.** Water obtained, from a potable source approved by the Mississippi State Health Department will not be required to be tested; otherwise, as applicable, a routine analysis of the sample of water submitted will be made. If the routine analysis indicates that any of the specified limits for acidity or alkalinity, organic solids, or inorganic solids are exceeded, the water may be further tested by either or both of the following methods as determined by the MDOT Materials Engineer.

1. A chemical analysis to determine the nature of the specified characteristics for which minimum values are established.
2. Strength and Time-of-Set Test. Results of additional tests may be considered satisfactory if:
  - (a) The solids are found to be not detrimental to the materials with which the water is used;
  - (b) The alkali carbonates and bicarbonates do not exceed 0.1% by weight of water when the combination of carbonates and bicarbonates is calculated to sodium carbonate,  $\text{Na}_2\text{CO}_3$ ;
  - (c) The 28-day strength of mortar with the water is not less than 90% of that made with distilled water; and
  - (d) The time of set is not less than 45 minutes.

In general, water will be approved if it complies with the applicable requirements of the Standard Specifications, or if the results of additional tests as provided above are determined by the MDOT Materials Engineer to be satisfactory.

No formal tests of water used for granular subbase, base, or embankment construction, or in connection with the planting and establishment of vegetation will be made unless the Engineer questions the quality of the water.



**S-714.02--Calcium Chloride.** Calcium chloride shall conform to the requirements of AASHTO Designation: M 144. Calcium chloride shall not be used in concrete which will be prestressed; nor shall it be used in other concrete unless specifically approved by the Engineer.

**S-714.03--Lime.**

**S-714.03.1--General.** Lime shall be stored and handled in closed, weather-proof containers until used. If local storage is provided, lime shall be used only from approved storage facilities and shall meet the requirements of the contract at the time of use.

**S-714.03.2--Hydrated Lime.** Hydrated lime for use in mortar shall conform to the requirements of ASTM Designation: C 207, Type N.

Hydrated lime for soil stabilization shall conform to the following requirements:

Calcium and magnesium oxides (nonvolatile basis), %, min. ....	90
Carbon dioxide, %, maximum .....	7
Moisture loss, 2 hrs. @ 120°C, maximum .....	3

Gradation of Residue:

Retained on No. 30 sieve, %, maximum .....	2.5
Retained on No. 200 sieve, %, maximum .....	15

**S-714.03.3--Quick Lime.**

**S-714.03.3.1--Granular or Pelletized Quick Lime.** Granular or pelletized quick lime for soil stabilization shall be a commercial granular or pelletized quick lime and shall conform to the following requirements prior to slaking:

Calcium and magnesium oxides, nonvolatile basis, %, minimum ....	90
Carbon dioxide, %, maximum .....	7
Gradation, percent passing by weight:	
¾ inch sieve .....	100
No. 4 sieve .....	0-30

The Contractor shall furnish certified test reports with each shipment of quick lime attesting to the purity of the lime and that the lime meets the requirements of the specifications; however, the material shall be subject to inspection, test, or rejection by the Engineer at any time.

**S-714.03.3.2--Dry Quick Lime.** Dry quick lime used for soil stabilization by the dry application method shall be a commercial quick lime and shall conform to the following requirements after two minutes on a Ro-tap shaker:

<u>Sieve</u>	<u>Percent Passing By Weight</u>
No. 10	100
No. 20	90 - 100
No. 100	0 - 20
No. 200	0 - 5

Dry quick lime shall meet the slaking standards as defined in ASTM Designation: C 110, and shall reach maximum heat rise in no more than six (6) minutes.

The Contractor shall furnish certified test reports with each shipment of quick lime attesting to the purity of the lime and that the lime meets the requirements of the specifications; however, the material shall be subject to inspection, test, or rejection by the Engineer at any time.

**S-714.03.4--Bag Lime.** When bag lime is used, the bag shall bear the weight certified by the manufacturer. Bags varying more than five percent from the certified weight will be rejected, and the average weight of 50 bags in any shipment taken at random shall not be less than the certified weight. Bag lime shall conform to the requirements of hydrated or quick lime as applicable.

**S-714.03.5--Limestone Dust.** The source of the material shall be approved by the Engineer and meet the following gradation requirements:

SIEVE	PERCENT PASSING
No. 30	95-100
No. 200	20-100

**S-714.04--Sodium Chloride.** Sodium chloride shall conform to the requirements of AASHTO Designation: M 143.

**S-714.05--Fly Ash.**

**S-714.05.1--General.** When required or permitted in construction, fly ash shall be obtained from an approved source. The acceptance of fly ash shall be based on certified test reports, certification of shipment from the supplier, and tests performed on samples obtained after delivery in accordance with the Office of State Aid Road Construction's Standard Operating Procedures.

Different classes of fly ash or different sources of the same class shall not be mixed or used in the construction of a structure or unit of a structure, without written permission from the Engineer. The Contractor shall provide suitable means for storing and protecting the fly ash against dampness. Fly ash, which for any reason, has become partially set or which contains lumps of caked fly ash shall not be used.

The temperature of the bulk fly ash shall not be greater than 165°F at the time of incorporation into the work.

In addition to the above requirements fly ash shall meet the following specific requirements for the intended use.

**S-714.05.2-Fly Ash for Use in Concrete.** When used with portland cement (Types I or II) in the production of concrete, grout, or in soil stabilization, the fly ash shall meet the requirements of AASHTO Designation: M 295, Class C or Class F, with the following exceptions:

The loss on ignition shall not exceed 6.0 percent.

The Pozzolanic activity index with portland cement, at 7 days, shall be at least 55 percent of the control mix. The water requirement shall not exceed 105 percent of the control mix.

Fly ash shall not be used with portland cement Type IP.

**S-714.05.3-Fly Ash for Soil Stabilization.** When used with hydrated lime in soil stabilization, the class of fly ash shall be as specified in the contract. The fly ash, when mixed with hydrated lime and soil or soil-aggregate, shall produce the minimum design characteristics for the course to be stabilized. The fly ash shall meet the requirements of AASHTO Designation: M 295 for the class specified, except the loss on ignition shall not exceed 10.0 percent.

**S-714.06--Ground Granulated Blast Furnace Slag (GGBFS).**

**S-714.06.1--General.** GGBFS shall be obtained from an approved source. The acceptance of GGBFS shall be based on certified test reports, certification of shipment from the supplier and tests performed on samples obtained after delivery in accordance with the Office of State Aid's Standard Operating Procedures.

The Contractor shall provide suitable means for storing and protecting the GGBFS against dampness and contamination. Separate storage silos, bins, or containers shall be provided for GGBFS. GGBFS which has become partially set, caked or contains lumps shall not be used.

The Engineer shall be notified in writing of the nature, amount and identity of any processing or other additions made to the GGBFS during production.

GGBFS from different mills shall not be mixed or used alternately in any one class of construction or structure without written permission from the Engineer; except that this requirement will not be applicable to cement treatment of design soil, subbases or bases.

In addition to these requirements, GGBFS shall meet the following specific requirements.

**S-714.06.2--Specific Requirements.** GGBFS shall meet the requirements of AASHTO Designation: M 302, Grade 120. GGBFS shall contain no chlorides.

**S-714.07--Blank.**

**S-714.08--Frames, Grates, Covers, and Ladder Rungs.** Metal units shall conform to the plan dimensions and to the applicable requirements in S-716 or S-717.

Galvanizing, where specified for these units, shall conform to the requirements of AASHTO Designation: M 111, unless otherwise designated.

**S-714.09--Blank.**

**S-714.10--Elastomeric Bearings.**

**S-714.10.1--General.** This work shall consist of furnishing and installing elastomeric bearings in accordance with the plans and these specifications. All required testing and furnishing of sample bearings is considered to be part of the covered work. Shop drawings shall be approved by the Engineer prior to beginning of fabrication or production of bearings. Elastomeric bearings, as herein defined, shall include plain or nonreinforced pads consisting of elastomer only, and reinforced or laminated bearings consisting of elastomer reinforced with steel laminates.

All elastomeric bearings shall be furnished to the dimensions indicated on the plans. They shall be composed of the specified elastomer type, grade and hardness (or shear modulus); shall be adequate for the specified design load; shall be tested at the appropriate level; and shall satisfy any special requirements as shown on the plans.

**S-714.10.2--Elastomer.** The raw elastomer shall be virgin polychloroprene (Neoprene), Grade 3 (Ref. ASTM Designation: D 4014).

Elastomer for plain or non reinforced bearings shall be 70-Durometer, adequate for 800 psi design compression stress, and shall be tested to Level I as hereinafter described.

Unless otherwise shown on the plans, elastomer for laminated or reinforced bearing shall be 50-Durometer, adequate for 1,000 psi design compression stress, and shall be tested to Level I as hereinafter described.

An elastomer of higher grade number may be substituted for the specified grade.

The elastomer compound shall also meet the minimum requirements of Table I except as otherwise specified by the Engineer. When test specimens are cut from the finished product, a 10 percent variation in physical properties shall be permitted. All material tests shall be carried out at  $73^{\circ}\text{F} \pm 4^{\circ}\text{F}$  unless otherwise specified.

TABLE I

MATERIAL PROPERTY	ASTM DESIGNATION	TEST REQUIREMENTS	POLYCHLOROPRENE			UNITS
			50 DURO	60 DURO	70 DURO	
Physical Properties	D2240 D412	Hardness Min. tensile strength Min. ultimate elongation	50±5 2250 400	60±5 2250 350	70±5 2250 300	Shore A Pts. psi %
Heat Resistance at specified temp.	D573	Specified temperature of test-22hrs. Aging time Max. change in durometer hardness Max. change in tensile strength Max. change in ultimate elongation	212 70 +15 -15 -40	212 70 +15 -15 -40	212 70 +15 -15 -40	°F Hours Shore A Pts. % %
Compression Set at specified Temp.	D395 Method B	Specified temperature of test degrees Max. permissible set	212 35	212 35	212 35	°F %
Ozone Resistance	D1149	Partial pressure of ozone during test Duration of test Tested at 20% strain 100°F±2°F mounting procedure D518, Procedure A	50 100 no cracks	50 100 no cracks	50 100 no cracks	mPa Hours
Low Temperature	D2137 Method A D1415 or D2240	Low temperature Brittleness Test (required for Grade 3 & 5 only) at -13°F for Grade 3 and -40°F for Grade 5 Low temperature stiffness (required for Grades 2, 3 and 5 only). Conditioned for 22 hours at 14°F for Grade 2, -13°F for Grade 3 and -40°F for Grade 5. Max. change in hardness	no failure	no failure	no failure	Shore A Pts.
	D1229	Max. low temperature compression set (required for Grades 2, 3 and 5 only) when tested at 25% compression for: 22 hours at 32°F for Grade 2, 7 days at 14°F for Grade 3, 14 days at each of 14°F and -13°F for Grade 5.	+15 65	+15 65	+15 65	%

**S-714.10.3--Steel Laminates.** Steel laminates used for reinforcement shall be made from rolled mild steel conforming to ASTM Designation: A 36 or A 1011, unless otherwise specified by the Engineer. The laminates shall have a minimum nominal thickness of 16-gauge. Holes in plates for manufacturing purposes shall be considered in design.

**S-714.10.4--Bonding Adhesive.** The vulcanized bond between the elastomer and steel laminates shall have a minimum peel strength of 40 pounds per inch. The peel strength shall be performed in accordance with ASTM Designation: D 429, Method B.

**S-714.10.5--Fabrication.**

**S-714.10.5.1--General.** Plain pads shall be cast as a single unit in individual molds under heat and pressure except leveling pads 3/8 inch or less in thickness may be sheared. Bearings with steel laminates shall be cast as a unit in a mold and bonded and vulcanized under heat and pressure. The molds shall have standard shop practice mold finish. The internal steel laminates shall be sandblasted and cleaned of all surface coating rust and mill scale before bonding, shall be free of sharp edges and burrs, and shall have a minimum edge cover of 1/8 inch.

Flash tolerance, finish, and appearance shall meet the requirement of the latest edition of the Rubber Handbook as published by the Rubber Manufacturers Association, Inc., RMA F3 and T.063 for molded bearings and RMA F2 for extruded bearings.

**S-714.10.5.2--Tolerances.** Plain pads and laminated bearings shall be built to the design dimensions and these specifications with the following tolerances:

(a)	Overall Vertical Dimensions	(Inches)
	Design Thickness 1 1/4" or less	-0, +1/8"
	Design Thickness > 1 1/4"	-0, +1/4"
(b)	Overall Horizontal Dimensions	
	36" and less	-0, +1/4"
	over 36"	-0, +1/2"
(c)	Thickness of Individual Layers of Elastomer	
	Laminated Bearings Only at any point within the bearing	±20% of design value but no more than ±1/8"

(d)	Variation from a Plane Parallel to the Theoretical Surface as determined by measurements at the edge of the bearings:	
	Top	slope relative to bottom of no more than .005 radians
	Sides	1/4"
(e)	Position of Exposed Connection Members	1/8"
(f)	Edge cover of Embedded Laminates or Connection Members	-0, +1/8"
(g)	Size of Holes, Slot or Inserts	<u>+1/8"</u>
(h)	Position of Holes, Slots, or Inserts	<u>+1/8"</u>

**S-714.10.6--Acceptance Procedure.** The acceptance criteria shall be at two levels. Level I acceptance shall be applied to all elastomeric bearings. Level II acceptance criteria shall be applied as required on the plans or contract documents. Level II criteria shall also be used to resolve differences over the acceptance of bearings to which only Level I tests have been applied.

Level I criteria require that bearing pads be manufactured according to this specification and any additional requirements specified on the plans. The manufacturer shall proof load each steel reinforced bearing with a compressive load of 1500 psi. If bulging patterns imply laminate placement which does not satisfy design criteria and manufacturing tolerances or if bulging suggests poor laminate bond, the bearing shall be rejected. If there are 3 separate surface cracks which are greater than 0.08 inch wide and 0.08 inch deep, the bearing shall be rejected.

A copy of the proof loading results for each lot of steel reinforced bearings shall be furnished to the Engineer prior to shipment of the bearings.



The Office of State Aid Road Construction reserves the right to require that proof loading be done in the presence of and witnessed by a representative of the Engineer. Whether an Engineer representative was present to witness the proof loading or not, the manufacturer's certification concerning compliance with the requirements of the contract shall attest to acceptable proof loading.

Level I criteria require that the elastomer satisfy the minimum properties of Table I. Level I criteria also include bond test for laminated bearings (ASTM Designation: D 429, Method B).

Level II certification requires that all Level I conditions be satisfied, except that individual conditions may be waived by the Engineer if Level II certification is used as an arbitration of disputes. Additionally, shear modulus and compressive stiffness shall be determined in accordance with ASTM Designation: D 4014. The shear modulus shall fall within the range of values specified in the following Table. Compressive stiffness tests shall be performed on the complete bearing. The compressive stiffness shall vary by no more than  $\pm 10$  percent from the median value of all bearings.

**TABLE**

<b>HARDNESS (SHORE A)</b>	50	60	70
Shear Modulus at 73°F (psi)	85-100	120-155	160-200

The Contractor shall furnish to the Engineer three copies of the manufacturer's certified test reports and certification that each lot in a shipment complies with the requirements of the contract.

**S-714.10.7--Marking.** Each reinforced bearing shall be marked in indelible ink or flexible paint. The marking shall consist of the order number, lot number, bearing identification number, and elastomer type and grade number. Unless otherwise specified in the contract documents, the marking shall be on a face which is visible after the erection of the bridge.

**S-714.10.8--Sampling.** A lot for plain bearings shall be the manufacturer's lot. Each designated thickness of laminated bearings used on a project shall constitute a lot. Unless otherwise specified on the plans or in the contract documents, sampling shall be at the rate of one bearing per lot. The supplier shall produce sufficient extra bearings (pads) to accommodate this sampling. Bearings (pads) from within a lot shall be selected at random by the Engineer as samples for inspection and testing.

**S-714.11--Portland Cement Mortar and Grout.**

**S-714.11.1--General.** The ingredients for portland cement mortar and grout shall conform to the following requirements:

1. Portland Cement - S-701.01
2. Masonry Cement - S-701.02
3. Water - S-714.01.2
4. Fine aggregate unless otherwise designated shall conform to the requirements of S-703.02 or S-703.18
5. Calcium chloride - S-714.02
6. Hydrated lime - S-714.03.2
7. Fly Ash - S-714.05
8. Limestone Dust - S-714.03.5

**S-714.11.2--Grout for Pressure Grouting.** Grout for pressure grouting shall consist of a mixture of portland cement, water, calcium chloride, fly ash and/or limestone dust and fine sand in the proportions set forth in S-612.02.2.

Fine sand shall meet the following requirements:

<u>Square Mesh Sieve</u>	<u>Percent Passing by Weight</u>
No. 10	100
No. 60	40-90
No. 200	0-50
Percent Silt	0-25
Percent Clay	0-12
Percent Organic Material	0-3
Plasticity Index	N.P.

**S-714.11.3--Grout for Posttensioned Members.** Grout for posttensioned members shall consist of a mixture of:

1 part portland cement, Type 1

1/4 part fly ash

3/4 part washed sand (all passing No 16 sieve,  
not more than five percent retained on No. 30 sieve)

Four to six gallons of water per bag of cement

A plasticizing admixture, subject to approval by the Engineer, shall be used in accordance with the manufacturer's recommendations.

The grout shall be mixed in a mechanical mixer, shall have the consistency of heavy paint and shall be agitated until placed.

Members shall not be moved before the grout has set; ordinarily 24 hours minimum at 80°F or higher.

**S-714.11.4--Blank.**

**S-714.11.5--Masonry Mortar.** Masonry mortar shall consist of masonry cement mixed in accordance with the formula shown on the bag or shall consist of one part portland cement, three parts mortar sand (the addition of hydrated lime will be permitted in the proportion of 1/10 part by volume of the cement), and sufficient water to make a mortar of such consistency that it can be easily handled and spread with a trowel.

Mortar for use in other than masonry work, fine aggregate meeting the requirements of S-703.02 may be used.

Unless an approved mortar mixing machine is used, the sand and mortar mix, or cement and lime, shall be mixed dry in a tight box until the mixture assumes a uniform color, after which water shall be added as the mixing continues until the mortar attains the proper consistency.

Mortar shall be used within 45 minutes after its preparation. Retempering of mortar will not be permitted.

**S-714.11.6--Rapid Setting Commercial Grouts and Concrete Patching Compounds.**

Rapid setting commercial grouts and concrete patching compounds must be approved for listing in the MDOT's "Approved Sources of Materials" prior to use, and shall be premeasured and packaged dry by the manufacturer. All liquid solutions included by the manufacturer as components of the packaged material shall be packaged in a watertight container. The manufacturer may include aggregates in the packaged material or recommend the addition of Contractor furnished aggregates.

The type, size and quantity of aggregates, if any, to be added at the job site shall be in accordance with the manufacturer's recommendations and shall meet the requirements of S-703.02 for fine aggregate and S-703.03 for coarse aggregate. Required mixing water to be added at the job site shall meet the requirements of S-714.01.2.

Only those bonding agents, if any, recommended by the manufacturer of the grout or patching compounds may be used for increasing the bond to old concrete or mortar surfaces.

Grout or patching compounds containing chlorides will not be permitted when in contact with steel.

Site preparation, proportioning of materials, mixing, placing and curing shall be performed in accordance with the manufacturer's recommendation for the specific type of application, and the Contractor shall furnish a copy of these recommendations to the Engineer.

Rapid setting non-shrink commercial grouts and concrete patching compounds, including components to be added at the job site, shall conform to the following physical requirements:

Compressive strength shall equal or exceed 3000 psi in 24 hours when tested in accordance with Mississippi Test Method MT-4.

Bond strength shall equal or exceed 100 psi in 24 hours when tested in accordance with Mississippi Test Method MT-4.

The material shall not shrink, and the increase in length at 28 days shall not be greater than 0.3% when tested in accordance with Mississippi Test Method MT-4.

The Contractor shall furnish to the Engineer three copies of the manufacturer's certified test report(s) showing results of all required tests and certification that the material meets the specifications when mixed and placed in accordance with the manufacturer's instructions. When the mixture is to be placed in contact with steel, the certification shall further state that the packaged material contains no chlorides. Certified test report(s) and certification shall be furnished for each lot in a shipment.

The proportioning of materials must be approved by the MDOT Materials Engineer, or other approved lab, and any subsequent change in proportioning must also be approved. A sample of each component shall be submitted to the Engineer along with the quantity or percentage of each to be blended. At least 45 days must be allowed for initial approval.

The proportioning of materials for subsequent lots may be approved by the MDOT Materials Engineer, or other approved lab, upon receipt of certification from the manufacturer that the new lot of material is the same composition as that originally approved and that the material has not been changed or altered in any way.

#### **S-714.11.7--Commercial Grout for Anchoring Doweled Tie Bars in Concrete.**

**S-714-11.7.1--Epoxy Grout Anchor System.** Epoxy grout shall consist of one part liquid epoxy to a maximum of four parts clean dry silica sand by volume. The epoxy shall be a two-component epoxy-resin bonding system for application to portland cement concrete. The silica sand shall be bagged general purpose blast cleaning sand. The grout shall be placed with equipment that dispenses the grout evenly around the bar and completely fills the hole. Tamping the material in the hole by hand will not be satisfactory.

**S-714.11.7.2--Non-Expanding Chemical Anchor System.** Chemical anchor system shall consist of a premeasured unit containing polymeric or epoxy type resin, a hardener and may also include quartz sand aggregate. The resin and hardener shall be isolated from each other by a physical-chemical barrier or may be contained in separate premeasured units.

**S-714.11.7.3--Installation.** Unless otherwise specified, installation and hole sizes shall be in accordance with the manufacturer's recommendations.

**S-714.11.7.4--Acceptance Procedure.** The anchor system must be one from MDOT's "Approved Sources of Materials". Prior to use, the Contractor shall furnish the Engineer three copies of the manufacturer's certification for each shipment stating that the material furnished is of the same composition as that originally approved and that the material has not been changed or altered in any way.

Each day an in-place tension test shall be performed at random on a tie bar with a maximum curing time of two hours. If the test fails to meet the total load required to stress the bar to 50,000 psi, three additional tests shall be made at random. If any of the additional tests fail, all bars installed on that day shall be tested and any bar that fails shall be replaced. The Contractor shall furnish the testing device which shall include a certified calibration chart. No separate measurement for payment will be made for the testing device.

#### **S-714.11.8--Epoxy Joint Repair System.**

**S-714.11.8.1--General.** When the epoxy system is from MDOT's current list of "Approved Sources of Materials", the Contractor shall furnish the Engineer three copies of the manufacturer's certification, for each shipment, stating that the epoxy and all components is the same composition as that originally approved and that the material has not been changed or altered in any way.

If the materials proposed for use are not from the MDOT's current list of approved materials, a sample of the epoxy and all components required for the epoxy mortar mix shall be submitted to the Engineer for evaluation and approval at least 30 calendar days prior to placement. Subsequent approval of each shipment may be by manufacturer's certification as set out above.

A representative of the epoxy manufacturer must be present for sufficient time to assure that the Contractor is properly schooled in the use of the epoxy materials.

**S-714.11.8.2--Epoxy Resin.** The material shall meet the requirements of ASTM Designation: C 881, Type I, Grade 2, Class C.

**S-714.11.8.3--Silica Sand.** The material shall be bagged general purpose blast cleaning sand.

**S-714.11.8.4--Epoxy Mortar Mix.** The mortar mix shall consist of one part liquid epoxy to 3.5 parts clean dry sand by volume.

**S-714.11.8.5--Mixing and Curing.** Mixing of all epoxy materials shall be accomplished with a mechanical mixer. A trial batch of mortar, approximately one cubic foot, will be mixed and used for joint repair. From this batch, the pot life and subsequent amount of material to be mixed will be determined.

**S-714.12--Sprayed Finish for Concrete Surfaces.** The spray material shall be an approved commercial product designed specifically for a sprayed finish and when applied to the concrete specimens at a rate of one gallon per 50 square feet shall conform to the following requirements:

**S-714.12.1--Freeze-Thaw Test.** Cast and cure three concrete specimens, not less than 4" x 6" x 6", of the mix designed for the structure. Fourteen days moist curing with a drying period in room air at 60° to 80°F for 24 hours before coating with spray finish is required. Caution shall be taken that there be no excessive oil on specimen forms. Coat sides of specimens (brush permitted) as hereinbefore set out and cure at room temperature for 48 hours; after which:

1. Immerse in water at room temperature (60° to 80°F) for three hours; remove and,
2. Place in cold storage at -15°F for one hour; remove and,
3. Thaw at room temperature (60° to 80°F) for one hour.
4. Repeat Steps 2 and 3 to complete a total of 50 cycles.

At the end of 50 cycles of Freeze/Thaw Test, the specimens shall show no visible defects.

**S-714.12.2--Accelerated Weathering.** Material shall be subjected to a 5000 hour exposure test in accordance with ASTM Designation: G 151. Testing shall be performed in conjunction with either ASTM Designation: G 153, Carbon Arc Light Apparatus, or ASTM Designation: G 155, Xenon Arc Light Apparatus. Test Exposure Conditions shall be as specified in Table X1.1, Cycle 1 in ASTM Designation: G 153, or Table X3.1, Cycle 1 in ASTM Designation: G 155. At the end of the exposure test, the exposed sample must not show any chipping, flaking or peeling.

**S-714.12.3--Fungus Growth Resistance.** Material to be used shall pass a fungus resistance test as described by ASTM Designation: D 3273 with a minimum incubation period of 21 days where no growth shall have been indicated after the test.

**S-714.12.4--Color.** The color of the finish shall be that deemed by the Engineer to be as close as practicable to the color of a rubbed concrete finish.

**S-714.12.5--Testing and Certification.** All testing shall be performed by a qualified commercial testing laboratory acceptable to the State Aid Engineer.

Before part of a shipment is applied on the project, the Contractor shall furnish the Engineer with a certificate from the manufacturer attesting that the commercial product furnished conforms to the same formula as that previously subjected to the specified tests, and approved. Copies of the current test reports shall be attached to the certificate.

No test report for tests made more than four years prior to shipment to the project will be accepted.

**S-714.13--Geotextiles.**

**S-714.13.1--General.** Unless specified otherwise, the geotextile may be woven or non-woven. The fibers used in the manufacture of the geotextiles and the threads used in joining geotextiles by sewing, shall consist of long-chain synthetic polymers, composed of at least 95% by weight polyolefins, polyesters, or polyamides. They shall be formed into a network such that the filaments or yarns retain dimensional stability relative to each other, including selvages. The geotextile shall be mildew resistant and inert to biological degradation and naturally encountered chemicals, alkalines and acids. Geotextile which is not protected from sunlight after installation shall contain stabilizers and/or inhibitors to make it resistant to deterioration from direct sunlight, ultraviolet rays, and heat.

The edges of the geotextile shall be salvaged or finished in such a manner to prevent the outer yarn of filaments from raveling. The geotextile shall be free of defects or flaws, which affect the required physical properties.

Geotextile for silt fence shall be manufactured in widths of not less than three feet, and geotextile for other applications shall be manufactured in widths of not less than six feet. Sheets of geotextile may be sewn or bonded together at the factory or other approved locations, but deviation from the physical requirements will not be permitted.

Acceptance testing, except geotextile for silt fence, will be conducted with geotextile samples from each lot shipped to the project, as per Subsection S-714.13.10.

**S-714.13.2--Geotextile for Silt Fence.** The geotextile shall conform to the physical requirements of Type I or II as shown in Table I. Unless a specific type is specified in the plans or contract documents, the Contractor may select Type I or II.

**S-714.13.2.1--Woven Wire Backing.** Except as provided herein, silt fence shall be reinforced with a woven wire backing. The wire backing shall be at least 32 inches high and have no less than six horizontal wires. Vertical wires shall be spaced no more than 12 inches apart. The top and bottom wire shall be 10 gage or larger. All other wire shall be no smaller than 12 1/2 gage.

**S-714.13.2.2--Posts.** Wood or steel posts may be used. Wood posts shall have a minimum diameter of three inches and length of five feet and shall be straight enough to provide a fence without noticeable misalignment. Steel tee posts shall be five feet long, approximately 1 3/8 inches wide, 1 3/8 inches deep, and 1/8 inch thick with a nominal weight of 1.33 pounds per foot prior to fabrication. The posts shall have projections, notches or holes for fastening the wire backing or geotextile to the posts.



**S-714.13.2.3--Staples.** Staples shall be made of nine gage wire with a minimum length of one inch after bending.

**S-714.13.3--Geotextile for Subsurface Drainage.** Unless otherwise specified, the geotextile shall conform to the physical requirements of Type III as shown in Table I.

**S-714.13.3.1--Geotextile for Edge Drains.** The geotextile shall conform to the physical requirements of Type V as shown in Table I, except the AOS for the woven geotextile shall have a range of 0.15 mm to 0.43 mm.

**S-714.13.4--Geotextile Underseal.** The geotextile shall be non-woven polyester or polypropylene, which is satisfactory for use with asphalt cements. Unless otherwise specified, the geotextile shall conform to the physical requirements of Type IV in Table I.

**S-714.13.5--Geotextile for Use Under Riprap.** Unless otherwise specified, the geotextile shall conform to the physical requirements of Type V in Table I. The requirements for grab tensile, puncture, and trapezoidal tear strengths may be reduced 50 percent when the geotextile is cushioned from rock placement by a 6-inch minimum layer of sand.

**S-714.13.6--Geotextile Stabilization.** The geotextile shall meet the physical requirements as shown in Table I for the Type specified in the plans or contract documents.

**S-714.13.7--Securing Pins.** Steel pins used for anchoring the geotextile shall be three-sixteenth inch (3/16") in diameter, minimum length of 15 inches, pointed at one end and fabricated with a head for retaining a steel washer. A minimum one and one-half inch (1 1/2") washer shall be installed on each pin.

**S-714.13.8--Identification.** Each roll of geotextile or container shall be visibly labeled with the name of the manufacturer, type of geotextile or trade name, lot number, and quantity of material.

**S-714.13.9--Shipment and Storage.** During shipment and storage, the geotextile shall be protected from direct sunlight, ultraviolet rays, temperatures greater than 140°F, mud, dirt, dust, and debris. The geotextile shall be wrapped and maintained in a heavy-duty protective covering, including ends of roll.

**S-714.13.10--Acceptance By Certification.** The Contractor shall furnish to the Engineer three copies of the manufacturer's certification that each lot in a shipment complies with the requirements of the contract. Certification of geotextile fabric shall include a material conformance statement, as per S-700.05.1, that the geotextile fabric meets or exceeds the minimum average roll values specified in Table I. All geotextile, steel pins, washers, fence posts, woven wire and wire staples are subject to approval by the Engineer upon delivery to the work site.

714.13.11 – Table.

TABLE I, GEOTEXTILES

Type Designation Application	I <sup>a</sup>		II <sup>a</sup>		III	IV	V	VI		VII	Test Method
	Sediment Control		Drainage					Separation & Drainage			
Physical Properties											
Grab Strength, Pounds	50	90	110	90	200	W 280	NW 180	W 450	NW 280	ASTM D 4632	
Elongation %	-----	50% max @ 45 lbs.	20% min	50% min @ break	50% min	50% max	50% min	50% max	50% min	ASTM D 4632	
Seam Strength, Pounds	-----	-----	70	-----	180	240	160	400	240	ASTM D 4632	
Puncture Strength, Pounds	-----	-----	40	-----	80	110	75	180	115	ASTM D 4883	
Trapezoidal Tear, Pounds	-----	-----	40	-----	80	100	70	150	100	ASTM D 4533	
Asphalt Retention, gallons / square yard	-----	-----	-----	0.2	-----	-----	-----	-----	-----	ASTM D 6140	
Permittivity, sec <sup>-1</sup>	0.05	0.05	0.5	-----	0.15	0.2	0.2	0.2	0.2	ASTM D 4491	
AOS Woven, mm	0.15 - 0.84	0.15 - 0.84	0.15 - 0.43	-----	0.21 - 0.43	0.15 - 0.21	-----	0.15 - 0.21	-----	ASTM D 4751	
AOS Non-Woven, mm	<0.84	<0.84	<0.43	-----	<0.43	-----	<0.43	-----	<0.43	ASTM D 4751	
Tensile Strength after UV, % Retained	70@500 Hr.	70@ 500 Hr.	70@ 150 Hr.	-----	70@ 150 Hr.	70@ 150 Hr.	70@ 150 Hr.	70@ 150 Hr.	70@ 150 Hr.	ASTM D 4355	
Melting Point, °F	-----	-----	-----	325	-----	-----	-----	-----	-----	ASTM D 276	

a. All property values, with the exception of apparent opening size (AOS), represent minimum average roll values in the weakest principal direction. Values for AOS represent the maximum average roll values.

## **SECTION S-715 - ROADSIDE DEVELOPMENT MATERIALS**

### **S-715.01--Topsoil.**

**S-715.01.1--General.** Topsoil shall be a well-graded soil of good uniform quality, without detrimental admixture of subsoil, refuse, or foreign material and reasonably free of hard clods, stones, cement, brick, slag, concrete, sticks, or other undesirable material harmful to plant life.

**S-715.01.2--Material to be Obtained from the Right-of-Way.** Topsoil for slope treatment shall meet the general requirements as stated above and shall have a pH value of not less than 4.5 nor more than 8.0.

**S-715.01.3--Material to be Furnished by the Contractor.** Topsoil for slope treatment shall meet the general requirements of S-715.01.1, shall have a pH value of not less than 4.5 nor more than 8.0, and shall be classified as a group A-4 or A-6 soil with minimum PI of 6.0 as specified by AASHTO Designation: M 145.

**S-715.01.4--Sampling and Testing.** Sampling and testing of topsoil shall be as set out in S-700.03.

### **S-715.02--Fertilizers.**

**S-715.02.1--General.** Fertilizers shall comply with the fertilizer laws of the State of Mississippi.

**S-715.02.2--Commercial Combination or Manufactured Fertilizer.** Combination or manufactured fertilizer shall be "standard commercial products" and shall contain not less than the percentages by weight of the ingredients set out in Table A, except for agricultural limestone which shall meet the requirements of S-715.02.2.1.

TABLE A  
TYPES OF FERTILIZERS

	COMBINATION								MANUFACTURED				
									Super Phosphate	Ammonium Nitrate	Urea	Muriate Potash	Ureaform
	* 10	18	6	15	12	8	0	13					
	10	46	8	10	24	24	20	13					
	10	0	8	10	12	24	20	13					
CHEMICAL COMPONENTS													
Nitrogen	* 10	18	6	15	12	8	0	12		33	45		38
Phosphorous P <sub>2</sub> O <sub>5</sub>	10	46	8	10	24	24	20	13	20				
Potash K <sub>2</sub> O	10	0	8	10	12	24	20	13				60	

\*Ureaform (38-0-0) – This fertilizer shall contain a minimum of 38% total nitrogen, 27% of which shall be insoluble nitrogen derived from ureaform. The final mixture shall have a minimum activity index (AI) of 50% as determined by the appropriate AOAC procedure.

\*Ureaform (10-10-10) – This fertilizer shall contain a minimum of 10% total nitrogen, 35% of which shall be insoluble nitrogen derived from ureaform. The final mixture shall have a minimum activity index (AI) of 40% as determined by the appropriate AOAC procedure.

**S-715.02.2.1- Agricultural Limestone.** Agricultural limestone shall be either a Grade “A” liming material, or a marl or chalk agricultural liming material as addressed in the latest Mississippi Agricultural Liming Material Act of 1993, published by the Mississippi Department of Agriculture and Commerce.

**S-715-02.2.1.1--Screening Requirements.** Grade “A” liming material, including ground shells, shall not have less than 90% of the material passing the No. 10 sieve, and not less than 50% passing the No. 60 sieve. Marl or chalk liming material shall not have less than 90% of the material passing the No. 10 sieve.

**S-715-02.2.1.2--Neutralizing Values.** Grade “A” liming material shall not have less than 90% calcium and magnesium carbonate calculated as calcium carbonate equivalent when expressed on a dry weight basis. Marl or chalk liming material shall not have less than 70% calcium and magnesium carbonate calculated as calcium carbonate equivalent when expressed on a dry weight basis.

**S-715.02.3--Sampling and Testing.** Sampling and testing of agricultural limestone shall be in accordance with S-700.03. Labels on containers or attached thereto showing the guaranteed analysis of other fertilizers will be prima facie evidence as to conformity with the specified requirements.

**S-715.03--Seed.**

**S-715.03.1--General.** All seeds shall comply with the seed law of the State of Mississippi and the current regulations duly promulgated thereunder. The seed shall be delivered in bags with certified tags or labels attached to each bag showing the name (kind and variety), percent of germination and purity of the seed, and the percent of obnoxious weeds and inert matter.

**S-715.03.2--Germination and Purity Requirements.** The requirements for germination and purity shall be as set out in Table B:

**TABLE B**  
**GERMINATION AND PURITY REQUIREMENTS**

Name (Kind)	Name (Variety)	Percent Germination	Percent Purity
<b>GRASSES</b>			
Bermudagrass	Common	85	95
Bahiagrass	Pensacola or Wilmington	85	85
Tall Fescue	Kentucky 31	80	95
Lovegrass	Weeping	80	97
Carpetgrass	-----	80	85
Millet	Browntop	85	98
Oats	-----	90	98
Rye Grain	-----	80	98
Centipede	-----	80	85
<b>LEGUMES</b>			
Crimson Clover	Dixie, Chief, Tibbee or Autauga	85	98
Annual Lespedeza	Kobe, Summit, or Climax	80	98
Sericea Lespedeza	Common, Interstate or Serala	80	98
Lespedeza	Vergata	90	98
Vetch	Hairy	85	95

**S-715.03.3--Sampling and Testing.** Except as provided in S-214.02, the certified analysis shown on the seed bags will be used to determine the purity, obnoxious seeds, and inert matter as to conformance with the above requirements. Seeds from bags not identified by certified analysis or from bags with certified analysis indicating the seeds do not meet contract requirements shall not be used.

All seeds may be sampled and tested for percent germination, and the Engineer reserves the right to sample and test seeds for any required characteristic when deemed appropriate to do so as a check on the quality of the seeds; in which case the results of such tests shall be the basis for acceptance, rejection, or adjustment under the provisions of the contract.

Samples of seed to be tested will be taken by personnel under the supervision of the Engineer. The seeds will be sampled by means of a trier (probe) through the seed bags. A 1/4 pound sample will be required from each seed lot with equal quantities being taken from each sack within a lot to make up the sample.

**S-715.03.4--Leguminous Inoculants.** Approved legume seeds shall be treated with leguminous inoculant under the supervision of the Engineer. The inoculants for treating leguminous seeds shall be standard, pure culture of nitrogen fixing bacteria. The seed shall be treated at the rate specified and according to the directions shown on the container of the inoculants and before the expiration date for use of the inoculant as also shown on the container.

**S-715.04--Water.** Water used in planting and establishment of vegetation shall comply with the applicable requirements of S-714.01.

**S-715.05--Vegetative Materials for Mulch.** The vegetative materials for mulch shall be classed as follows:

Type I. Approved baled straw of wheat, oat, rye grain, rice, broomsage or Bahia grass (with seed heads) which has reached maturity prior to cutting.

Type II. Approved baled hay produced from Bermuda, Bahia, Fescue, Dallis Grass, any of the Lespedezas, or combinations thereof.

All of the above materials shall have been properly cured prior to baling and shall be reasonably free from Johnson Grass and other obnoxious grasses and weeds. Vegetative material shall be reasonably bright in color, dry, and shall not be musty, moldy, or of otherwise low quality. Vegetative material that is wet or that has been baled green (nor cured properly) shall not be used.

Unless otherwise permitted in writing by the Engineer, Type I shall be furnished and used. The Engineer may permit the use of Type II when the Contractor has furnished satisfactory evidence in writing that Type I material is not available.

**S-715.06--Blank.**

**S-715.07--Mulch for Woody Plant Materials**. The mulch materials shall conform to the following.

**S-715.07.1--Tree Bark Mulch**. The mulch shall be a standard manufactured product of ground, shredded, or broken particles from the bark of trees and shall be reasonably free of weed seeds, harmful bacteria, or disease spores and substances toxic to plant growth. The mulch particles shall be of the following type(s), as specified in the contract:

Type I - Commonly known as extra coarse. Particle size shall be approximately one inch to 2 1/2".

Type II - Commonly known as coarse. Particle size shall be approximately 1/2 inch to one inch.

Type III - Commonly known as medium. Particle size shall be approximately 1/4 inch to 1/2 inch.

Type IV - Commonly known as fine. Particle size shall be approximately 1/8 inch to 1/4 inch.

All tree bark mulch shall be handled so as to insure proper protection against contamination at all times. The mulch shall be delivered to the job in unbroken bags or bales with a manufacturer's label or tag on each container. Labels or tags on the containers shall show the physical analysis of the contents, the size of the particles, and the volume. Labels on containers or attached thereto showing the guaranteed analysis and volume will be prima facie evidence of the materials meeting the above requirements. All mulch will, however, be subject to approval by the Engineer as to quality and quantity.

**S-715.07.2--Aggregate Mulch**. Aggregate used as mulch shall be crushed or uncrushed gravel Size 5 or Size 56 meeting the gradation requirements of S-703.14 for coarse aggregate cover material.

**S-715.07.3--Straw**. Straw material for mulch shall be classed as follows:

Class I - Approved baled wheat, oat, rice or rye straw. The materials shall have been cured properly prior to baling and shall be reasonably free from obnoxious grasses and weeds. The straw material shall be reasonably bright in color, dry and shall not be musty, moldy, or of otherwise low quality.

Class II - Approved baled pine needles that is reasonably free of twigs, branches, and obnoxious grasses and weeds. The material shall be dry and shall not be musty, moldy, or of otherwise low quality. All straw mulch shall be inspected and approved by the Engineer prior to its use.



**S-715.08--Fertilizer for Woody Plant Materials.** The fertilizer material for woody plants shall conform to the following requirements:

**S-715.08.1--Fertilizer Packet.** The fertilizer packet shall consist of an approved manufactured sealed polyethylene-paper laminated perforated packet containing one, two, or four ounces of water soluble fertilizer with a minimum guaranteed analysis of 16-8-16, 16% Nitrogen, 8% Phosphoric Acid, 16% Potash.

**S-715.08.2--Fertilizer Tablet.** The fertilizer tablet shall consist of an approved tightly compressed slow-release tablet 5, 10 or 21 gram size containing a minimum guaranteed analysis of 20-10-5, 20% Nitrogen, 10% Phosphoric Acid, 5% Potash.

**S-715.08.3--Guaranteed Analysis.** Labels on containers or attached thereto showing the guaranteed analysis will be prima facie evidence of the fertilizer materials meeting the specified requirements. All fertilizer packets and tablets will, however, be inspected and approved by the Engineer or, at the Engineer’s discretion, may be sampled and tested.

**S-715.09 - Ditch Liner Material.** All ditch liner materials shall be new and free of rips or tears.

**S-715.09.1--Jute Mesh.** Jute mesh shall be of uniform, plain weave with warp and weft yarns of approximately the same size. The physical requirements shall be:

Length	50 yards per roll, minimum
Width	48" plus or minus 1"
Warp ends	78 per width, minimum
Weft yarns	41 per yard, minimum

The weight of cloth Shall average 1.22 pounds per linear yard with a tolerance of plus 10% or minus 5%.

**S-715.09.2--Excelsior Blanket.** Excelsior blanket shall consist of a machine-produced mat of interlocking wood excelsior with uniform thickness and the fiber evenly distributed over the entire area of the blanket. A fabric net of extruded plastic shall be applied to one side of the excelsior wood mat to hold the wood fibers in place.

The blankets shall not be exposed to moisture prior to placing.

The blanket shall meet the following requirements:

Interlocking Wood Fibers	0.02" x 0.04" ( $\pm$ 25%) 50% must be 3 1/2" or longer
Fabric Net	1 1/2" x 3 1/2" maximum mesh size
Width	36" minimum

**S-715.09.3--Erosion Control Blanket.** The erosion control blanket shall consist of a machine-produced mat whose primary component is clean, weed-free straw from cereal grain crops. The straw must be evenly distributed throughout the mat. The top side of the blanket shall be covered with a photodegradable plastic mesh having 3/4" x 3/4" maximum openings which shall be substantially adhered to the straw by a knitting process using degradable thread. The blanket shall be supplied in a protective covering and shall meet the following requirements:

Straw *	0.50 pounds per square yards minimum dry weight
Netting	Photodegradable plastic
Width	48-inch minimum

\* Coconut fiber may be used to replace a portion or all of the straw.

**S-715.09.4--Erosion Control Fabric.** Erosion control fabric shall consist of a flexible knitted construction of high strength degradable yarn with uniform openings interwoven with strips of biodegradable paper and shall conform to the following requirements:

Width	- 48 inches minimum
Weight	- 0.2 pound per square yard (approximate)

**S-715.09.5--Wire Staples.** The staples for securing the ditch liner material in place shall be a double prong "U" configuration made from 11-gauge or heavier steel wire with an approximate length of six inches after bending.

**S-715.09.6--Roving.**

**S-715.09.6.1--Polypropylene Roving.** This material shall be formed from continuous strands of fibrillated polypropylene yarn, collected into a rove. Fibrillation is defined as a net-like physical structure of the yarn created by splitting the yarn in a precise pattern during manufacture.

The polypropylene shall contain a sufficient amount of UV inhibitors so as to retain 70 percent of its strength after 500 hours of exposure in an Atlas Twin Arc Weatherometer.

The fibrillated polypropylene roving shall have the following detailed requirements:

<u>Property</u>	<u>Limits</u>	<u>Test Method</u>
Strands / Rove	20-30	End Count
Yards per Pound of Rove	410-620	ASTM Designation: D 1907
Package Weight, pounds	18 minimum	Scale
Color	Black	

**S-715.09.6.2--Fiberglass Roving.** The material shall be formed from continuous fibers drawn from molten glass, coated with a chrome-complex sizing compound, collected into strands, and lightly bound together into a rove.

The fiberglass roving material shall meet the following detailed requirements:

<u>Property</u>	<u>Limits</u>	<u>Test Method</u>
Yield, yards per pound	170 - 300	ASTM Designation: D 578
Fiber Diameter, inch	0.00035 - 0.00055	ASTM Designation: D 578
Strands / Rove	50 - 70	End Count
Package Weight, pounds	25-50	Scale

**S-715.09.7--Certification.** The Contractor shall furnish the Engineer with three copies of the manufacturer's certification for each shipment of ditch liner material stating the amount furnished and that the material complies with the requirements of the specifications and also forward three copies of the manufacturer's or distributor's certification showing the wire size for each shipment of staples.

The certifications by the manufacturer or distributor will be prima-facie evidence of the materials meeting the specified requirements. All ditch liner material and staples will, however, be subject to approval by the Engineer.

## **SECTION S-716 - MISCELLANEOUS METALS**

**S-716.01--General.** All miscellaneous metals shall be as shown on the plans or in the special provisions, and shall conform to the requirements as hereinafter set out, unless otherwise specified.

Unless waived by the State Aid Engineer, the Contractor shall furnish the Engineer three copies of certified test reports from an approved testing laboratory covering all material described in this section.

### **S-716.02--Steel Castings.**

**S-716.02.1--Carbon Steel Castings.** Carbon steel castings shall conform to AASHTO Designation: M 103. Grade 70-36 shall be furnished unless otherwise specified.

**S-716.02.2--Chromium Alloy-Steel Castings.** Chromium alloy-steel castings shall conform to ASTM Designation: A 743. Grade CA-15 shall be furnished unless otherwise specified.

**S-716.03--Steel Forgings.** Steel forgings shall conform to AASHTO Designation: M 102. Class C forgings shall be furnished unless otherwise specified.

**S-716.04--Gray Iron Castings.** Gray iron castings shall conform to AASHTO Designation: M 105. Class 30B shall be furnished unless otherwise specified. For testing purposes a lot size shall be defined as the lesser of either a total of 35,000 pounds or one week's production for State/County projects. The test bar shall be made from a melt of iron used in production of units for the Project(s). The test bar length shall be a minimum of 16 inches.

**S-716.05--Malleable Castings.** Malleable castings shall conform to ASTM Designation: A 47. Grade No. 35018 shall be furnished unless otherwise specified.

**S-716.06--Bronze Castings and Bearings.** Bronze castings and bearings shall conform to AASHTO Designation: M 107. Alloy UNS No. C91100 shall be furnished unless otherwise shown on the plans.

### **S-716.07--Copper Bearings and Sheet Copper.**

**S-716.07.1--Rolled Copper-Alloy Bearings and Expansion Plates.** Rolled copper-alloy bearings and expansion plates shall conform to AASHTO Designation: B 100 Alloy UNS No. C51000 shall be furnished unless otherwise specified.

**S-716.07.2--Sheet Copper.** Sheet copper shall meet the requirements of AASHTO Designation: M 138 including the embrittlement test. The Copper No. shall be as designated on the plans.

**S-716.08--Self-Lubricating Bearing Plates.** Self-lubricating bearing plates shall be an article of standard production by an established manufacturer of such equipment. They shall be provided with trepanned or drilled recesses (not grooves) which shall be filled with a lubricating compound capable of withstanding the atmospheric elements and consisting of graphite and metallic substances with a lubricating binder. This compound shall be pressed into the recesses by hydraulic presses so as to form dense nonplastic lubricating inserts. The lubricating area shall comprise not less than 25% nor more than 35% of the total bearing area. Contractor shall furnish additional lubricating material in stick form. Just prior to erecting the members which rest on the bronze plates, the Contractor shall thoroughly rub the steel bearing plates, which rest on the bronze, with the lubricant. These surfaces shall be unpainted and shall be cleaned with a steel brush immediately before the lubricant is applied.

The bearing plates shall be made of (1) rolled bronze conforming to the requirements of S-716.06 or (2) cast bronze conforming to requirements of S-716.05, Alloy UNS No. C91100 or No. C90500, except that a maximum lead content of 2.5% is allowable.

The coefficient of friction shall not exceed 0.10 when subjected to design loading and also when subjected to twice the design loading.

Contact surfaces shall be finished in the direction of motion in accordance with the requirements of ANSI B46 1-55 No. 125. All machined surfaces shall be flat within 0.0005 inch per inch of length and width. In mating curved surfaces of steel and bronze, the concave surfaces may have a plus tolerance of 0.01 inch and the convex surfaces, minus tolerance of 0.01 inch.

The Contractor shall furnish the manufacturer's shop drawings showing pattern and size of recesses.

**S-716.09--Babbitt.** Babbitt shall conform to ASTM Designation: B 23. The alloy number shall be as designated on the plans.

**S-716.10--Lead Plates, Pipes, Etc.** Lead used for plates, pipes, etc. shall conform to ASTM Designation: B 29 , Grade: Pure Lead.

**S-716.11--Galvanized Pipe.** Galvanized pipe for water, gas, etc., shall conform to ASTM Designation: A 53.

**S-716.12--Rolled Zinc.** Rolled zinc shall conform to ASTM Designation: B 69. The type shall be as designated on the plans.

**S-716.13--Electrical Conduit.** Electrical conduit, including couplings, bends, and nipples, shall conform to Federal Specifications for Conduit, Electrical, Steel Rigid, Zinc-Coated.

**S-716.14--Bar Grates.**

**S-716.14.1--Material Requirements.** Plain round steel bars and strap bars shall conform to the following requirements:

B-9 Grates and Bar Grates:	AASHTO Designation: M 270, Grade 36
MI, GI, & SS-3 Grates:	AASHTO Designation: M270, Grade 50W, or ASTM Designation: A 588, Grade 50W

**S-716.14.2--Fabrication and Finish.** All bar grates shall be constructed in accordance with the specifications and in conformity with the detailed plans.

Holes shall be punched or drilled in the strap bars to accommodate the round bars. The junctions of all round bars and/or strap bars shall be welded. The complete bar grate shall exhibit good workmanship.

After fabrication, the bar grate shall be coated with an approved commercial quality coating designed for coating steel castings and fabricated units. The Engineer shall approve the coating material prior to application.

**SECTION S-717 - STRUCTURAL STEEL**

**S-717.01--Structural Steel.**

**S-717.01.1--General.** Steel shall be furnished according to the following specifications. Unless otherwise specified, structural carbon steel shall be furnished. Steels other than those required herein may be specified on the plans. When steel is used in welded construction, the welding procedure shall be suitable for the steel and the intended service.

**S-717.01.2--Requirements for Structural Steel.** Structural steel shall meet the applicable ASTM Standards which shall include the Supplementary Bend Test Requirement and the following Charpy V-Notch Requirements for minimum service temperature 0°F and above:

<b>ASTM DESIGNATIONS</b>	<b>THICKNESS &amp; FABRICATION</b>	<b>MINIMUM CHARPY V-NOTCH ENERGY @ TEMPERATURE</b>
A 36	Up to 4"	15 ft. lb. @ 70°F
*A 588	Up to 4" Mech. Fastened	15 ft. lb. @ 70°F
*A 588	Up to 2" Welded	15 ft. lb. @ 70°F
*A 588	Over 2" to 4" Welded	20 ft. lb. @ 70°F
*A 572	Up to 4" Mech. Fastened	15 ft. lb. @ 70°F
*A 572	Up to 2" Welded	15 ft. lb. @ 70°F
*A 572	Over 2" to 4" Welded	20 ft. lb. @ 70°F
A 514	Up to 4" Mech. Fastened	25 ft. lb. @ 30°F
A 514	Up to 2 1/2" Welded	25 ft. lb. @ 30°F
A 514	Over 2 1/2" to 4" Welded	35 ft. lb. @ 30°F
A 852	Up to 4" Mech. Fastened	20 ft. lb. @ 50°F
A 852	Up to 2 1/2" Welded	20 ft. lb. @ 50°F
A 852	Over 2 1/2" to 4" Welded	25 ft. lb. @ 50°F

\* If the yield strength of the material exceeds 65 ksi, the temperature for the CVN value for acceptability shall be reduced 15°F for each increment, or fraction thereof, of 10 ksi above 65 ksi.

The procedure for sampling and testing shall be in accordance with ASTM Designation: A 673. The (H) Frequency of Heat Testing shall be used for all the steel specifications except ASTM Designation: A 514 which shall be in accordance with the (P) Frequency of Piece Testing. If ASTM Designation: A 517 steel is used in lieu of A 514, the sampling and testing requirements shall be the same as the A 514 of equal thickness.

**S-717.01.3--Structural Carbon Steel.** Structural carbon steel for bolted and welded construction shall be in accordance with ASTM Designation: A 36.

**S-717.01.4--Eyebars.** Steel for eyebars shall be a weldable grade. These grades include structural steel conforming to:

- (a) Structural Carbon Steel ASTM Designation: A 36.
- (b) High-Strength Low-Alloy Structural Steel with 50,000 psi, minimum yield point to 4" thick, ASTM Designation: A 588 with supplementary requirements for Charpy V-Notch mandatory.

**S-717.01.5--High Strength Low-Alloy Structural Steel.** High-Strength Low-Alloy Structural Steel shall conform to:

- (a) High-Strength Low-Alloy Columbium-Vanadium Steels of Structural Quality, ASTM Designation: A 572.
- (b) High-Strength Low-Alloy Structural Steel with 50,000 psi, minimum yield point to 4" thick, ASTM Designation: A 588.

**S-717.01.6--High Strength Low-Alloy Structural Steel for Welding.** High Strength Low- Alloy Structural Steel for welding shall conform to:

- (a) High-Strength Low-Alloy Columbium-Vanadium Steels of Structural Quality, ASTM Designation: A 572, Grade 50.
- (b) High-Strength Low-Alloy Structural Steel with 50,000 psi, minimum yield point to 4" thick, ASTM Designation: A 588.

**S-717.01.7--High Strength Structural Steel for Bolted Construction.** High-Strength Structural Steel for bolted construction shall conform to:

- (a) High-Strength Low-Alloy Columbium-Vanadium Steels of Structural Quality, ASTM Designation: A 572, Grade 50.
- (b) High-Strength Low-Alloy Structural Steel with 50,000 psi, minimum yield point to 4" thick, ASTM Designation: A 588.

**S-717.01.8--High-Yield-Strength, Quenched, and Tempered Alloy Steel Plate.** High-Yield-Strength, Quenched and Tempered Alloy Steel Plate shall conform to:

- (a) High-Yield Strength, Quenched and Tempered Alloy Steel Plate, suitable for welding, ASTM Designation: A 514
- (b) High-Strength Alloy Steel Plates, Quenched and Tempered for pressure vessels, ASTM Designation: A 517.



**S-717.01.9--Acceptance Procedure.** Structural Steel shall be accepted on the basis of manufacturer's certified test reports. The Contractor shall furnish the Engineer with three copies of the certified test reports.

**S-717.02--Fasteners.** Fasteners for structural steel joints shall conform to the ASTM specifications with revisions, as specified herein.

**S-717.02.1--Plain Finish Fasteners.**

**S-717.02.1.1-Bolts.** Ungalvanized bolts shall meet the requirements of ASTM Designation: A 325 or ASTM Designation: A 490, as specified on the plans.

**S-717.02.1.2-Heavy Hex Nuts.** Ungalvanized nuts shall meet the requirements of ASTM Designation: A 194, Grade 2H, or A 563, Grade DH, as specified on the plans.

**S-717.02.1.3--Hardened Washers.** Ungalvanized washers shall meet the requirements of ASTM Designation: F 436.

**S-717.02.2--Galvanized Fasteners.**

**S-717.02.2.1--Galvanized Bolts.** Bolts shall meet the requirements of ASTM Designation: A 325, Type 1. Galvanizing shall be in accordance with ASTM Designation: A 153, Class C, or ASTM Designation: B 695, Class 50. Thickness of zinc coating shall be measured on the wrench flats or top of bolt head.

**S-717.02.2.2--Galvanized Nuts.** Nuts shall meet the requirements of ASTM Designation: A 563, Grade DH. Galvanizing shall be in accordance with ASTM Designation: A 153, Class C, or ASTM Designation: B 695, Class 50. Thickness of zinc coating shall be measured on the wrench flats.

**S-717.02.2.3--Galvanized Washers.** Washers shall meet the requirements of ASTM Designation: F 436. Galvanizing shall be in accordance with ASTM Designation: A 153, Class C, or ASTM Designation: B 695, Class 50.

**S-717.02.2.4--Direct Tension Indicators.** Direct tension indicators shall meet the requirements of ASTM Designation: F 959 and galvanized in accordance with ASTM Designation: B 695, Class 50.

**S-717.02.3--Revisions to ASTM Specifications.**

**S-717.02.3.1--ASTM Designation: A 325.** Hardness for bolt diameters 1/2-inch to 1-inch inclusive shall have a minimum Rockwell C Hardness Number of 24 and a maximum Rockwell C Hardness Number of 33.

**S-717.02.3.2--ASTM Designation: A 563.** Nuts that are to be galvanized shall be tapped oversize the minimum amount required for proper assembly. The amount of overtap in the nut shall be such that the nut will assemble freely on the bolt in the coated condition and shall meet the rotational-capacity test set out in S-717.02.3.4.

The overtapping requirements of ASTM Designation: A 563, Subsection 7.4, shall be considered maximum values instead of minimum, as currently shown.

Galvanized nuts shall be lubricated with a lubricant containing a dye of any color that contrasts with the color of the galvanizing.

**S-717.02.3.3--ASTM Designation: F 606.**

**S-717.02.3.3.1--Bolts.** Proof load tests shall be performed in accordance with Method 1, Length Measurement. Minimum frequency of tests shall be as specified in ASTM Designation: A 325 for "Production Lot Method." Wedge tests on full size bolts are required. If bolts are to be galvanized, the tests shall be performed after galvanizing. Minimum frequency of tests shall be as specified in ASTM Designation: A 325, "Production Lot Method."

**S-717.02.3.3.2--Nuts.** Proof load tests shall be performed in accordance with ASTM Designation: F 606, Subsection 4.2. If nuts are to be galvanized, tests shall be performed after galvanizing, overtapping and lubricating.

**S-717.02.3.3.3--Washers.** If galvanized washers are supplied, hardness testing shall be performed after galvanizing. The coating shall be removed prior to taking hardness measurements.

**S-717.02.3.4--Rotational-Capacity Testing of Assemblies.** Rotational-capacity tests are required and shall be performed on all black or galvanized (after galvanizing) bolt, nut and washer assemblies by the manufacturer or distributor prior to shipping. Washers are required as part of the test even though they may not be required as part of the installation procedure. Except as modified herein, the rotational-capacity test shall be performed in accordance with the requirements of ASTM Designation: A 325. The following shall apply:

- (a) Each combination of bolt production lot, nut lot and washer lot shall be tested as an assembly. Where washers are not required by the installation procedures, they need not be included in the lot identification.
- (b) A rotational-capacity lot number shall be assigned to each combination of lots tested.
- (c) The minimum frequency of testing shall be two assemblies per rotational-capacity lot.
- (d) The bolt, nut and washer assembly shall be assembled in a Skidmore-Wilhelm Calibrator or an acceptable equivalent device. For short bolts which are too short to be assembled in the Skidmore-Wilhelm Calibrator see (h) below.
- (e) The minimum rotation, from a snug tight condition (10% of the specified proof load), shall be:
  - 240° (2/3 turn) for bolt lengths < 4 diameters
  - 360° (1 turn) for bolt lengths > 4 diameters and < 8 diameters
  - 480° (1-1/3 turn) for bolt lengths > 8 diameters
- (f) The tension reached at the above rotation shall be equal to or greater than 1.15 times the required installation tension. The installation tension and the tension for the turn test are shown below:

Diameter (in.)	1/2	5/8	3/4	7/8	1	1 1/8	1 1/4	1 3/8	1 1/2
Req. Installation Tension (kips)	12	19	28	39	51	56	71	85	103
Turn Test Tension (kips)	14	22	32	45	59	64	82	98	118

- (g) After the required installation tension listed above has been exceeded, one reading of tension and torque shall be taken and recorded. The torque value shall conform to the following:

$$\text{Torque} \leq 0.25 PD$$

Where:

- Torque = measured torque (foot-pounds)
- P = measured bolt tension (pounds)
- D = Bolt diameter (feet)

- (h) Bolts that are too short to test in a Skidmore-Wilhelm Calibrator may be tested in a steel joint. The tension requirement of (f) above need not apply. The maximum torque requirement of (g) above shall be computed using a value of P equal to the turn test tension shown in the table in (f) above.

**S-717.02.4--Reporting.** The results of all tests (including zinc coating thickness) required herein and in the appropriate ASTM specifications shall be recorded on the appropriate document. Location where tests are performed and date of tests shall be reported on the appropriate document. The manufacturer or distributor that performs the test shall certify that the results recorded are accurate. The manufacturer shall certify that the steel and the assembly components are domestic products.

**S-717.02.5--Documentation.**

**S-717.02.5.1--Mill Test Report(s) (MTR).** MTR shall be furnished for all mill steel used in the manufacture of the bolts, nuts, and washers. MTR shall indicate the place where the material was melted and manufactured.

**S-717.02.5.2--Manufacturer Certified Test Report(s) (MCTR).** The manufacturer of the bolts, nuts, and washers shall furnish the Office of State Aid Road Construction three copies of test reports (MCTR) for the items furnished. Each MCTR shall have the appropriate MTR attached. Each MCTR shall contain the information required in S-717.02.4.

The manufacturer performing the rotational-capacity test shall include on the MCTR the following:

- (a) The lot number of each of the items tested.
- (b) The rotational-capacity lot number as required in paragraph (b) of S-717.02.3.4.
- (c) The results of the tests required in S-717.02.3.4.
- (d) The pertinent information required in S-717.02.4.
- (e) A statement that MCTR for the items are in conformance to this specification and the appropriate ASTM specifications.
- (f) The location where the bolt assembly components were manufactured.

**S-717.02.5.3--Distributor Certified Test Report(s) (DCTR).** The following shall be applicable for DCTR:

- (a) The DCTR shall include MCTR above the various bolt assembly components.
- (b) The rotational-capacity test may be performed by a distributor (in lieu of a manufacturer) and reported on the DCTR.
- (c) The DCTR shall show the results of the tests required in S-717.02.3.4.
- (d) The DCTR shall also show the pertinent information required in S-717.02.4.
- (e) The DCTR shall show the rotational-capacity lot number as required in paragraph (b) of S-717.02.3.4.
- (f) The DCTR shall certify that the MCTR are in conformance to this specification and the appropriate ASTM specifications.

**S-717.02.6--Shipping.** Bolts, nuts and washers (where required) from each rotational-capacity lot shall be shipped in the same container. If there is only one production lot number for each size of nut and washer, the nuts and washers may be shipped in separate containers. Each container shall be permanently marked with the rotational-capacity lot number such that identification will be possible at any stage prior to installation. Three copies of the appropriate MTR, MCTR or DCTR shall be furnished to the Engineer.

**S-717.02.7--Final Acceptance.** Final acceptance of high strength bolts, nuts, washers and direct tension indicators will be based on tests performed on samples obtained from the project by the Engineer. Tests will be performed in accordance with the procedures set out in these specifications. A lot shall be defined as each shipment to a project from the manufacturer's lot number and of the same size and length. The integrity of each lot shall be maintained until tests are completed by the MDOT.

Each lot of bolts, shall be sampled as follows:

<b>Lot Size</b>	<b>Sample Size</b>
150 or less	2
151 to 280	4
281 to 500	6
501 to 1200	10
1201 to 3200	16
3201 to 10,000	26
10,001 and over	40

Note: One-half of the sampled bolts will be used for tensile testing and the other one-half will be tested for coating and/or hardness.

Each lot of nuts or washers, shall be sampled as follows:

<b>Lot Size</b>	<b>Sample Size</b>
800 or less	1
801 to 8000	2
8001 to 22,000	3
22,001 and over	5

Note: The sample size shall be doubled when galvanized nuts or washers are specified or used.

Each lot of direct tension indicators shall be sampled as follows:

<b>Lot Size</b>	<b>Sample Size</b>
35,000 or less	16
35,001 to 250,000	26
250,001 and over	32

Direct tension indicators shall be tested in accordance with ASTM Designation: F 959. One-half of the samples will be tested in compression and the remaining one-half will be tested for coating.

**S-717.03--Copper Bearing Steels.** When copper bearing steel is specified, the steel shall contain not less than 0.2 percent copper.

**S-717.04--Welded Stud Shear Connectors.**

- (a) Shear connector studs shall conform to the requirements of Cold Finished Carbon Steel Bars and Shafting, ASTM Designation: A 108 Cold-Drawn Bars, Grades 1015, 1018, or 1020, either semi or fully killed. If flux retaining caps are used, the steel for caps shall be of a low carbon grade suitable for welding and shall comply with Cold-Rolled Carbon Steel Strip, ASTM Designation: A 109.
- (b) Tensile properties as determined by tests of bar stock after drawing or of finished studs shall conform to the following requirements:

Tensile Strength	(min.)	60,000 psi
Yield Strength*	(min.)	50,000 psi
Elongation	(min.)	20% in 2 inches
Reduction of area	(min.)	50%

\*As determined by a 0.2 percent offset method.

- (c) Tensile properties shall be determined in accordance with the applicable sections of ASTM Designation: A 370, Mechanical Testing of Steel Products. Tensile tests of finished studs shall be made on studs welded to test plates. If fracture occurs outside of the middle half of the gage length, the test shall be repeated.

- (d) Finished studs shall be uniform quality and condition, free from injurious laps, fins, seams, cracks, twists, bends, or other injurious defects. Finish shall be as produced by cold drawing, cold rolling, or machining.
- (e) The manufacturer shall certify that the studs delivered are in accordance with the material requirements of this section. Certified copies of in-plant quality control test reports shall be furnished to the Engineer upon request.
- (f) The Engineer may select, at the Contractor's expense, studs of each type and size used under the contract, as necessary for checking the requirements of this section.

#### **S-717.05--Steel Grid Flooring.**

**S-717.05.1--Steel.** All steel shall conform to the Specification for Structural Steel of the ASTM Designation: A 36, ASTM Designation: A 572, Grade 50, or ASTM Designation: A 588. Unless the material is galvanized, it shall have a copper content of 0.2 percent.

**S-717.06--Pins and Rollers.** Steel for pins and rollers shall conform to the designations listed in Tables I and II below. Pins and rollers shall be accurately turned to the dimensions shown on the drawings and shall be straight, smooth, and free from flaws. Pins and rollers more than nine inches in diameter shall be forged rollers and annealed. Pins and rollers nine inches or less in diameter may be either forged and annealed or cold-finished carbon-steel shafting.

In pins larger than nine inches in diameter, a hole not less than two inches in diameter shall be bored full length along the axis after the forging has been allowed to cool to a temperature below the critical range, under suitable conditions to prevent injury by too rapid cooling, and before being annealed.

TABLE I

Minimum Material Properties Structural Steel				
Type	Structural Carbon Steel	High Strength Low-Alloy Steel	High Yield Strength Quenched and Tempered Alloy and Low Alloy Steel	
Designation ASTM	A 36	A 572 Grade 50	A 588	A 514/A 517
Thickness of Plates	Up to and including 8 inches.	Up to and including 4 inches.	Up to and including 4 inches	Over 2-1/2 inches up to and including 4 inches
Minimum Tensile Strength, Fu (psi)	58,000	65,000	70,000	100,000
Minimum Yield Point or Minimum Yield Strength, Fy (psi)	36,000	50,000	50,000	90,000



**TABLE II**

<b>Minimum Material Properties Pins and Rollers</b>			
Expansion rollers shall be not less than 4 inches in diameter			
ASTM Designation  Grade or Class	A 108  Grades 1016 to 1030 incl.	A 668  Class D	A 668 *  Class G
Size Limitations	4 inches or less in diameter	Up to 20 inches in diameter	Up to 10 inches in diameter  Up to 20 inches in diameter
Minimum Yield Point, psi Fy	36,000	37,500	50,000  50,000

## **SECTION S-718 - TIMBER AND DIMENSION LUMBER**

**S-718.01--Timber and Dimension Lumber. General.** All timber and dimension lumber shall be Southern pine and shall conform in all respects to applicable requirements of AASHTO Designation: M 168. Inspection for conformance to these specifications will be conducted in accordance with the SOP.

Timber and dimension lumber shall be furnished in the sizes shown on the plans or as specified. Unless otherwise specified, timber and dimension lumber shall be No. 1 SR, graded according to American Lumber Standards.

Only one type of preservative shall be used for the treatment of materials for any one class of construction on a project, unless otherwise specified.

**S-718.02--Untreated Timber and Dimension Lumber.** Untreated timber and dimension lumber shall comply with the requirements set out in S-718.01.

**S-718.03--Treated Timber and Dimension Lumber.** Timber and dimension lumber to be treated shall meet the requirements herein specified and shall be treated by a pressure method to the minimum required retainage of preservative as specified on the plans or elsewhere in the specifications. Treated timber or dimensional lumber will be subject to inspection by the Engineer both before and after treatment. Inspection prior to treatment may be waived by the Engineer when the preservative will be pentachlorophenol or chromated copper arsenate. The Contractor shall furnish three copies of the manufacture's certification that the material complies with the requirements as specified.

**S-718.03.1--Seasoning.** Seasoning timber, dimension lumber, piles and poles to be treated with preservatives shall conform to the requirements of AWPA.

### **S-718.03.2--Treatment.**

**S-718.03.2.1--General.** Insofar as practicable, each charge shall consist of pieces approximately equal in size, moisture, and sapwood content into which approximately equal quantities of preservative can be injected. Each layer of material shall be separated at each end, and at the center when necessary, by strips at least 3/8 inch in thickness; caps, stringers, and other large timbers shall be separated by strips of at least 1/2 inch thickness.

All timber and lumber shall be treated in accordance with AWPA treating practices unless otherwise specified herein.

Unless otherwise directed, the type and minimum quantity of preservative shall be in accordance with TABLES 1, 2 or 3.

Any treated timber or lumber to be painted shall be treated in accordance with S-718.04.3, Type B solvent, or S-718.04.4.

Brackish water, as listed in TABLES 1, 2 or 3, shall mean salt waters, bordering land, and waters adjacent thereto which are subject to tidal flow.

**S-718.03.2.2--Penetration.** Unless otherwise specified, treated timber and lumber shall show a 100 percent sapwood penetration or a minimum penetration of four inches.

The test method for determining the amount of preservative retained will be either as specified in AWPA or Mississippi Test Methods. The borer cores shall be obtained in accordance with AWPA Standard M2 and shall be taken from pieces having a sapwood depth at least equal to the sampling zone specified as follows:

- (a) Round Units (piling and poles) shall be in accordance with AWPA requirements.
- (b) Structural members less than four inches shall be from zero to one and one half inches from the surface.
- (c) All other structural members shall be from zero to two inches from the surface.

**S-718.03.2.3--Inspection.** The Engineer shall be notified sufficiently in advance of treating the material so that an inspector may be furnished at the plant to inspect the material and the treatment of same. All materials and processes used in the manufacture of the material shall be subject to inspection. The plant shall be equipped with the necessary gauges, thermometers, appliances, and facilities to enable the inspector to determine the conditions at all stages of the treatment and to satisfy himself that the requirements of the specifications are fulfilled. The manufacturer shall also provide the apparatus and chemicals necessary for making tests at the plant as required by these specifications. All equipment, apparatus, etc., shall be maintained in proper and satisfactory condition for use at all times.

Tests for penetration of preservative shall be made with an increment borer. Test holes shall be plugged with treated plugs. All borings shall be taken at the center of the narrow side of the piece. Sufficient borings shall be taken to insure that the specified penetration has been obtained, with a minimum of 20 borings required for each charge of materials.

If 20% or more of the borings from a charge of treated material fail to meet the penetration requirements, the entire charge shall be rejected and subject to retreatment. If upon retreatment, the material meets the penetration requirements, it will be accepted. Only one retreatment will be permitted, and any apparent damage due to retreatment shall be cause for rejection.

**S-718.03.3--Handling Treated Material.** Any bruising or rough handling will be cause for rejection.

**S-718.03.4--Storage of Treated Material.** All material treated for stock shall be stacked as compactly as possible on a well-drained surface. Material shall be supported on sills spaced as necessary, not to exceed 10 foot intervals and shall have at least one foot of air space beneath the stacks.

All materials treated with CCA for use in buildings and applications where painting is required shall be dried after treatment. The treated wood shall be kiln dried by American Lumber Standards, or air dried for a period of at least 21 days before shipment.

**S-718.04--Preservative.** The preservatives shall meet the applicable requirements of AWPA and the following:

The water content in an oil preservative shall not exceed 3.0% unless otherwise approved by the Engineer: in no case shall it exceed 5.0%.

**S-718.04.1--Creosote Oil.** The creosote oil shall meet the requirements of AWPA P-1. The test methods shall be either AWPA or Mississippi Test Methods.

**S-718.04.2--Creosote-Coal Tar Solution.** The creosote coal tar solution shall meet the requirements of AWPA P-2. The test methods shall be either AWPA or Mississippi Test Methods.

**S-718.04.3--Pentachlorophenol.** The pentachlorophenol shall meet the requirements of AWPA P-8. The test methods shall be either AWPA or Mississippi Test Methods.

The hydrocarbon solvent used in the pentachlorophenol solution shall meet the requirements of AWPA P-9, Type A or B. When painting is required, Type B solvent shall be used. Type A solvent shall be used for all other treatment unless otherwise specified.

**S-718.04.4--Chromated Copper Arsenate (CCA).** The solution shall contain a sufficient concentration of the water-born preservative to produce the minimum specified retention. The preservative shall meet the requirements of AWPA P-5, CCA Type B or C. The test methods shall be either AWPA or Mississippi Test Methods.

TABLE 1

MINIMUM TREATMENT RATES FOR CREOSOTE,  
AND CREOSOTE-COAL TAR PRESERVATIVES

Material	Coastal Area and Brackish Water		Other Locations	
	Retention Lbs/Cu. Ft	Preservative Required	Retention Lbs/Cu. Ft	Preservative Required
Lumber (1)	20	(3)	12	(2) or (3)
Piling	20	(3)	12	(2) or (3)
Poles	9	(2) or (3)	9	(2) or (3)

Notes: (1) - Lumber in the Coastal Area which will not be in contact with brackish water may be treated as specified for "Other Locations".

(2) - Creosote conforming to S-718.04.1.

(3) - Creosote-Coal Tar conforming to S-718.04.2.

TABLE 2

MINIMUM TREATMENT RATES FOR PENTACHLOROPHENOL  
PRESERVATIVE CONFORMING TO S-718.04.3

Material	Coastal Areas and Brackish Water	Other Locations
	Retention Lbs./Cu. Ft.	Retention Lbs./Cu. Ft.
Lumber	(1)	0.80
Piling	Penta Not Permitted	0.80
Poles	0.60	0.60
Material to be Painted	(2)	(2)

Notes: (1) - Pentachlorophenol not permitted for lumber which will be in contact with brackish water. Lumber in the Coastal Area which is not in contact with brackish water may be treated as specified for "Other Locations".

(2) - Treated at the rate specified above using AWPA P-9, Type B Solvent.

TABLE 3

MINIMUM TREATMENT RATE FOR CHROMATED COPPER  
ARSENATE PRESERVATIVE CONFORMING TO S-718.04.4

Material	Coastal Areas and Brackish Water	Other Locations
	Retention Lbs./Cu. Ft.	Retention Lbs./Cu. Ft.
Lumber (1)	2.50	0.80
Piling	2.50	0.80
Poles	0.60	0.60

Note: (1) Lumber in the Coastal Area which is not in contact with brackish water may be treated as specified for "Other Locations".

**SECTION S-719 - PILES**

**S-719.01--General.** Piles shall be untreated timber, treated timber, prestressed concrete, cast-in-place concrete, or steel piles, as specified and in addition to the general requirements of these specifications and the plans, shall conform to the specific requirements hereinafter set forth, unless otherwise stipulated.

**S-719.02--Timber Piles.** All piles shall conform to the requirements of ASTM Designation: D 25, except as hereinafter specified. Inspection for conformance to these specifications will be conducted in accordance with S-718.03.

The circumference and diameters of piling shall be in conformity with Table I.

**S-719.02.1--Untreated Timber Piles.** Untreated timber piles may be any species which will satisfactorily withstand driving. They shall be reasonably clean-peeled.

**S-719.02.2--Treated Timber Piles.** Treated timber piles shall be Southern Pine preferably cut during the winter season. Treated timber piles shall be inspected and treated in accordance with the requirements set forth in S-718.

**TABLE I**

**CIRCUMFERENCES AND DIAMETERS OF TIMBER PILES**

	Three Feet From Butt				At Tip	
	Minimum		Maximum		Minimum	
Length	Circumference	Approx. Diameter	Circumference	Approx. Diameter	Circumference	Approx. Diameter
Feet	Inches	Inches	Inches	Inches	Inches	Inches
Under 40	38	12	63	20	25	8
40 to 50 *	38	12	63	20	22	7
51 to 70 *	41	13	63	20	22	7
71 to 90 *	41	13	63	20	19	6
Over 90*	44	14	63	20	19	6
* Inclusive						



**S-719.03--Concrete Piles.** Concrete piles, both prestressed and cast-in-place, shall be constructed in conformity with the plans and in accordance with these specifications. Additional requirements for prestressed piles are set out in S-803.

All concrete materials and their preparation and placing shall be in accordance with the requirements of the class of concrete specified and in accordance with S-803.

Reinforcing steel shall conform to the requirements of S-711.

**S-719.04--Steel Piles.** The material in rolled steel piles shall be standard structural grade steel of the section number, size, and weight per linear foot indicated on the plans. The steel shall conform to the requirements of ASTM Designation: A 36.

The Contractor shall furnish the Engineer three certified copies of the mill test reports containing the true chemical and physical analyses of the material.

**S-719.05--Steel Sheet Piling.** Steel sheet piling shall conform to the requirements of ASTM Designation: A 328.

The Contractor shall furnish the Engineer with three certified copies of the mill test reports containing the true chemical and physical analyses of the material.

**SECTION S-720 - PAVEMENT MARKING MATERIALS**

**S-720.01--Glass Beads for 40 mil Hot Applied Spray Paint.** Shall meet the requirements of S-710.03.5 and S-710.03.6 unless stated otherwise. Glass beads for thermoplastic shall be Class A, unless otherwise specified.

**S-720.01.1--Class A.** The Class A, Standard, beads shall be Type 1, non-flotation with a moisture resistant coating conforming to the requirements of AASHTO Designation: M 247.

**S-720.01.2--Class B.** The Class B, High-Visibility, beads shall be non-flotation, embedment coated and conform to the following specific requirements.

**S-720.01.2.1--Gradation.** The beads shall meet the gradation requirements of Table 1.

**Table 1**

<u>U.S. Standard</u> <u>Sieve No.</u>	<u>% Retained</u>
12 .....	0
14 .....	0-5
16 .....	5-20
18 .....	40-80
20 .....	10-40
25 .....	0-5
Pan .....	0-2

**S-720.01.2.2--Roundness.** The beads shall have a minimum of 80 percent rounds per screen for the two (2) highest sieve quantities. The remaining sieve fractions shall be no less than 75 percent rounds.

**S-720.01.2.3--Angular Particles.** The beads shall have no more than three (3) percent angular particles per screen.

**S-720.01.2.4--Refractive Index.** The beads shall have a refractive index of 1.50 to 1.52.

**S-720.01.3--Packaging and Marking.** The beads shall be packaged in 50 or 55-pound moisture proofed bags. Each bag shall be stamped with the following information: name and address of manufacturer, shipping point, trademark or name, the wording "glass beads", class, weight, lot number and the month and year of manufacture.

**S-720.01.4--Acceptance Procedures.** The manufacturer shall furnish the Engineer three copies of the certified test report(s) showing results of all required tests and certification that the material meets the specifications.

**S-720.02--Temporary Raised Pavement Markers.****S-720.02.1--Material Requirements:**

- A. The temporary raised markers shall be flexible reflective tabs. The markers shall be yellow with amber reflective area on both sides. The body of the marker shall consist of a base and vertical wall made of polyurethane or other approved material and shall be capable of maintaining a reasonable vertical position after installation. The initial minimum reflectivity at an angle of incidence of 4° and an observation angle of 0.2° shall be 2.5.
- B. The markers shall be of standard size and quality with amenities as manufactured by: an approved manufacturer as listed on the Mississippi Department of Transportation's List of Approved Products for Traffic Marking Materials.
- C. The reflective material shall be protected with an easily removable cover of heat resistant material capable of withstanding and protecting the reflective material from the application of asphalt at temperatures exceeding 325°F.

**S-720.02.2--Certificates of Compliance.** The contractor shall furnish three copies of certifications from the manufacturer stating that the material meets the requirements of these specifications, (Reference S-106.04 of the standard specifications).

**S-720.03--Thermoplastic Pavement Markings.** The thermoplastic material shall conform to AASHTO Designation: M 249 except the glass beads shall be moisture resistant coated. Additional beads by the drop-on method shall be applied at a rate of not less than two pounds of beads per 100 feet of four-inch stripe.

The manufacturer/producers of the thermoplastic compound, glass beads, epoxy resin, and primer/sealer shall furnish to the Engineer three copies of certified test reports showing results of all tests specified therein and shall further certify that the materials meet all requirements.

**S-720.04--Cold Plastic Pavement Markings.**

**S-720.04.1--General.** The prefabricated markings described shall consist of white or yellow pigmented plastic films with reflective glass spheres uniformly distributed throughout their entire cross-sectional area, and be capable of being affixed to bituminous or portland cement concrete pavements by either a pressure sensitive pre-coated adhesive or a liquid contact cement. The markings shall be provided complete in a form that will facilitate rapid application and protect the markings in shipment and storage.

The manufacturer shall identify proper solvents and/or adhesives to be applied at the time of application, and equipment necessary for proper application, and recommendations for application that will assure an effective performance life.

Prefabricated legends and symbols shall conform to the applicable shapes and sizes as outlined in the "Manual on Uniform Traffic Control Devices", latest edition.

Cold plastic pavement markings shall be listed on MDOT's "Approved Sources of Materials". Prior to use, the Contractor shall furnish the Engineer three copies of the manufacturer's certification for each shipment stating that the material furnished is of the same composition as that originally approved by MDOT and that the material has not been changed or altered in any way.

**S-720.04.2--Requirements.** The material shall be 60 mil retroreflective pliant polymer film.

**S-720.04.2.1--Composition.** The retroreflective pliant polymer pavement marking film shall consist of a mixture of high quality polymeric materials, pigments, 1.5 index glass beads uniformly distributed throughout its cross sectional area and with a reflective layer of beads bonded to the top surface. The film shall be composed of the following materials:

<u>Material</u>	<u>Minimum Percent by Weight</u>
Resins & Plasticizers	20
Pigments	30
Graded Glass Beads	33

This film shall be capable of being fabricated into pavement markings of specified thickness and dimensions and of being adhered to asphaltic and/or portland cement concrete by means of a pressure sensitive precoated adhesive, or a liquid contact cement which is applied at the time of installation.

**S-720.04.2.2--Conformability and Resealing.** The retroreflective pliant polymer pavement marking film shall be capable of conforming to pavement contours, breaks, faults, etc., through the action of traffic at normal pavement temperatures. The film shall have resealing characteristics such that it is capable of fusing with itself and previously applied marking film of the same composition under normal conditions of use.

The film shall show patchability when tested as follows:

- a. Cut two 1" x 3" pieces of the pliant polymer and mark the reflective side of one of the pieces with a pencil to delineate a 1" x 1" area at the end of the piece.
- b. Wet the surface of the area delineated with a cloth soaked in contact cement or a mixture of MEK and toluene for one minute, keeping the surface wet. At the end of one minute, scrape the beads and binder off the sample and wipe the residual binder from the area. Let the sample dry for at least one minute.
- c. Remove the liner from the back of the second piece of film and place the backside on top of the cleaned area on the first piece. The sample (while held together) should now form one piece four inches long by 1 inch wide with the 1" x 1" overlap patch in the center.
- d. Place the patched sample on a hard surface under 1,000 grams per square inch (the area of the overlap splice) maintained at 140°F for two hours.
- e. Remove the sample from the heat and allow to cool to 70°F (room temperature).
- f. Pull the sample in opposite directions to place a shear strain on the patched area. The two pieces shall not separate without tearing.

**S-720.04.2.3--Tensile Strength.** The film shall have a minimum tensile strength of 40 pounds per square inch of cross section when tested according to ASTM Designation: D 638. A sample 6"x 1" x 0.06" shall be tested at a temperature between 70°F and 80°F using a jaw speed of 12 inches per minute.

**S-720.04.2.4--Elongation.** The film shall have a minimum elongation of 75% at break when tested according to ASTM Designation: D 638 using a jaw speed of 12 inches per minute.

**S-720.04.2.5--Plastic Pull Test.** A test specimen made the same size as in S-720.04.2.3 shall support a dead weight of four pounds for not less than five minutes at a temperature between 70°F and 80°F.

**S-720.04.2.6--Pigmentation.** The pigments shall be selected and blended to provide a marking film which is white or yellow conforming to standard highway colors through the expected life of the film.

**S-720.04.2.7--Glass Beads.** The glass beads shall be colorless and have a minimum index of refraction of 1.50 when tested using the liquid oil immersion method. The size and quality of the beads will be such that performance requirements for the retroreflective pliant polymer film shall be met.

Bead adhesion shall be such that beads are not easily removed when film surface is scratched firmly with thumbnail.

The film shall have glass bead retention qualities such that when a 2" x 6" sample is bent over a 1/2" diameter mandrel, with the 2" dimension perpendicular to the mandrel axis, microscopic examination of the area on the mandrel shall show no more than 10% of the beads with entrapment by the binder of less than 40%.

**S-720.04.2.8--Skid Resistance.** The surface of the retroreflective pliant polymer shall provide a minimum skid resistance value of 35 BPN when tested according to ASTM Designation: E 303.

**S-720.04.2.9--Reflective Intensity.** The photometric quantity to be measured shall be specific luminance and shall be expressed as millicandelas per square foot per foot candle. The minimum initial reflective values shall be 250 for white and 200 for yellow as measured in accordance with Mississippi Test Method MT-70.

**S-720.04.2.10--Reflective Retention.** The following tests shall be employed to measure reflectivity retention:

- (a) **Taber Abraser Simulation Test.** Using a taber abraser with an H-18 wheel and a 125 gram load, the sample shall be inspected at 200 cycles, under a microscope, to observe the extent and type of bead failure.

No more than 15% of the beads shall be lost due to pop-out and the predominant mode of failure shall be "wear down" of the beads.

- (b) **Qualitative Tests.** Bead bond strengths shall be judged under a microscope with a magnification of at least 5X. The beads shall be difficult to remove, and when removed, beads shall show a portion of the polymeric bead bond retained with the beads rather than clean removal from the sockets.

**S-720.04.2.11--Thickness.** Unless otherwise indicated on the plans, the retroreflective pliant polymer film, without adhesive, shall be supplied in a standard thickness of 0.06 inch.

**S-720.04.2.12--Effective Performance Life.** The film, when applied according to the recommendations of the manufacturer, shall provide a neat, durable marking that will not flow or distort due to temperature if the pavement surface remains stable. Although reflectivity is reduced by wear, the pliant polymer shall provide a cushioned, resilient substrate that reduces bead crushing and loss. The film shall be weather resistant and, through normal traffic wear, shall show no appreciable fading, lifting or shrinkage throughout the useful life of the marking, and shall show no significant tearing, roll back, or other signs of poor adhesion.

**S-720.04.3--Manufacturer's Certification.** The Contractor shall furnish the Engineer with three copies of the manufacture's certification stating that each lot in a shipment complies with the requirements of the contract. The Engineer reserves the right to select samples at random for testing.

**S-720.05--Preformed Pavement Markings for Construction Zones.**

**S-720.05.1--General.** In addition to the specific material requirements set forth herein, pavement marking materials must have been approved for listing in MDOT's "Approved Sources of Materials" prior to their use. The preformed markings shall consist of white or yellow retroreflective films on a conformable backing.

The size, quality, and refractive index of the glass beads shall be such that the performance requirements for the markings will be met. The bead adhesion shall be such that beads are not easily removed when the material surface is scratched with a thumbnail.

The pigments shall be selected and blended to provide pavement markings which are white or yellow and conform to standard highway colors.

The markings shall be precoated with a pressure sensitive adhesive and shall be capable of being adhered to asphalt concrete or portland cement concrete in accordance with manufacturer's instructions without the use of heat, solvents or other additional adhesive means, and shall be immediately ready for traffic after application.

The markings shall be provided in specified widths and shapes. Preformed words and symbols shall conform to the applicable shapes and sizes as outlined in the current edition of the MUTCD.

The materials shall be packaged in accordance with accepted commercial standards, and when stored in a cool dry area indoors shall be suitable for use for one year after the date of purchase.

**S-720.05.2--Classification of Markings.** Retroreflective preformed pavement markings shall be of the following types, as specified on the plans or bid sheets:

**S-720.05.2.1--Type 1.** The markings shall consist of a mixture of high quality polymeric materials, pigments and glass beads with a reflective layer of beads bonded to the top surface. A non-metallic medium coated with a pressure sensitive adhesive shall be incorporated to facilitate removal. The adhesive shall be of a type that is completely removed with the pavement marking or colorless so as not to leave a color mark on the pavement.

**Reflectance.** The markings shall meet or exceed the initial reflectance values when measured in accordance with the testing procedures of ASTM Designation: D 4592.

#### INITIAL REFLECTANCE VALUES

	<u>White</u>		<u>Yellow</u>	
Entrance Angle	86°		86°	
Observation Angles	0.2°	0.5°	0.2°	0.5°
SL (mcd/ft <sup>2</sup> /fc)	1770	1270	1310	820

The photometric quantity to be measured shall be specific luminance (SL) and shall be expressed in millicandelas per square foot per footcandle. The test distance shall be 50 feet, and the sample size shall be a 2.0 x 2.5-foot rectangle. The angular aperture of both the photoreceptor and light projector shall be six minutes of arc. The reference center shall be the geometric center of the sample, and the reference axis shall be taken perpendicular to the test sample.

The quantity SL (specific luminance) treats the retroreflector as a surface source rather than a point source whose projected area is visible as an area at the observation position. The quantity SL related to the way the effective retroreflective surface is focused on the retina of the human eye and to the visual effect thereby produced. It is recommended for describing the performance of highway signs and striping, or large vehicular markings which are commonly viewed as discernable surface areas.

**S-720.05.2.2--Type 2.** The pavement markings shall consist of retroreflective materials on a conformable metallic backing, precoated with a pressure sensitive adhesive which is colorless so as not to leave a color mark on the pavement or of a type that is substantially removed with the pavement marking.



**Reflectance.** The markings shall meet or exceed the initial reflectance values when measured in accordance with the testing procedures of ASTM Designation: D 4592.

#### INITIAL REFLECTANCE VALUES

	<u>White</u>		<u>Yellow</u>	
Entrance Angle	86°		86°	
Observation Angles	0.2°	0.5°	0.2°	0.5°
SL (mcd/ft <sup>2</sup> /fc)	1360	760	820	510

The sample size, test procedure and measurement of test values shall be as prescribed for Type 1 in S-720.05.2.1.

**S-720.05.3--Certificates of Compliance.** The Contractor shall furnish three copies of certifications from the manufacturer for each lot of pavement markings used stating that the material meets the requirements of the contract.

#### **S-720.06--Raised Pavement Markers.**

**S-720.06.1--General.** Raised pavement markers, including high performance raised pavement markers, shall be listed in MDOT's "Approved Sources of Materials".

**S-720.06.2--Type of Markers.** Pavement and jiggle markers shall conform to one or more of the following types:

- Type A - Non-Reflective White Jiggle Markers.  
Class 1- Acrylonitrile-Butadiene-Styrene Markers.  
Class 2 - Ceramic Markers.
- Type AY - Non-Reflective Yellow Jiggle Markers.  
Class 1 - Acrylonitrile-Butadiene-Styrene Polymer Markers.  
Class 2- Ceramic Markers.
- Type B - 2-Way Clear Reflective Markers.
- Type C - Red-Clear Reflective Markers.
- Type D - 2-Way Yellow Reflective Markers.
- Type E - One-Way Clear Reflective Markers.
- Type F - One-Way Yellow Reflective Markers.
- Type G - Yellow-Clear Reflective Markers.
- Type H - Chip Seal Clear Reflective Markers.
- Type I - Chip Seal Yellow Reflective Markers.

High performance raised pavement markers shall be available in Types B through G.

**S-720.06.3--Acceptance Procedures.**

**S-720.06.3.1--Marker Type A.** The Contractor shall furnish the Engineer three copies of the manufacturer's certified test reports covering all pavement markers shipped to the project. The certified test report shall show the test results on each part of each section contained in Mississippi Test Method MT-17 and shall state that the markers represented by the test results comply with the specifications contained herein in all respects.

The pavement markers will be accepted on the basis of the manufacturer's certified test reports. The Engineer reserves the right to obtain check samples as deemed necessary for determining compliance with this specification

**S-720.06.3.1.1--Marker Type B through G.** The Contractor shall furnish the Engineer three copies of the manufacturer's certified test reports covering all pavement markers shipped to the project. The certified test reports shall show the test results on each part of the applicable requirements of ASTM Designation: D 4280.

The pavement markers will be tentatively accepted on the basis of the manufacturer's certified test reports. The Engineer reserves the right to obtain check samples as deemed necessary for determining compliance with this specification.

**S-720.06.3.2--Marker Type H and I.** Prior to use, the Contractor shall furnish the Engineer three copies of a certification for each shipment stating that the material furnished is of the same composition as that originally approved by MDOT and that the material has not been changed or altered in any way. The Engineer reserves the right to obtain check samples as deemed necessary for determining compliance with this specification.

**S-720.06.4--Sampling, Tolerances, and Packaging.** Pavement markers shall conform to sampling, tolerance, and packaging requirements as set out below.

**S-720.06.4.1--Sampling.** For Marker Type A, H and I, ten (10) markers of each type and class, selected at random, will constitute a representative sample for each lot regardless of lot size.

For Marker Type B through G, check sampling, when performed, shall require ten (10) markers of each type, selected at random, to constitute a representative sample for each lot regardless of lot size.

A resample of any marker type will consist of twice as many markers as originally sampled.

**S-720.06.4.2--Tolerances.**

**S-720.06.4.2.1--Tolerances For Marker Type A, H & I.** At least 90% of the original sampling of each lot of markers shall pass all tests with the following exceptions:

When less than 90% but more than 70% pass all tests, a resample of that lot will be allowed at the request of the Contractor. When less than 70% of the markers from the original sample comply with the requirements, the lot represented by the samples will be rejected and no resample will be allowed. Tolerances for resamples shall be in the same ratio as specified above.

At least two of three specimens, randomly selected for strength, water absorption, and autoclave, and also the averages of the three, must pass the stated requirements; otherwise, three additional markers selected at random shall be tested, and if the same conditions for passing are not met for these latter three markers, the lot will be rejected.

**S-720.06.4.2.2--Tolerances For Marker Type B through G.** At least 90% of the check sampling of each lot of markers shall pass the strength test required in the Physical Properties Section of ASTM Designation: D 4280 with the following exceptions:

When less than 90% but more than 70% pass the test, a resample of that lot will be allowed at the request of the Contractor. When less than 70% of the markers from the check sample comply with the requirements, the lot represented by the samples will be rejected and no resample will be allowed. Tolerances for resamples shall be in the same ratio as specified above.

**S-720.06.4.3--Packaging.** Shipments shall be made in containers which are acceptable to common carriers and packaged in such a manner as to insure delivery in perfect condition. All damaged shipments shall be replaced by the Contractor.

Each package shall be clearly marked as to the name of the manufacturer, type, quantity enclosed, lot number, and date of manufacture.

**S-720.06.5--Non-Reflective Pavement Markers.** Non-reflective jiggle markers shall be either Class 1 or Class 2. Markers shall be approved products as listed on MDOT's "List of Approved Sources of Materials".

**S-720.06.5.1--Class 1 Markers.** Class 1 non-reflective jiggle markers shall consist of an acrylonitrile-butadiene-styrene polymer or other approved material, and shall be 4 inches wide x 6 inches long. Infrared curves of materials used in markers shall match approved curves on file at MDOT's Central Laboratory.

Class 1 markers shall conform to the following requirements when tested in accordance with Mississippi Test Method: MT-17.

<b><u>Property</u></b>	<b><u>Requirement</u></b>
Heat Resistance	No change in shape or appearance
Impact Resistance	No break, chip or crack
Load Resistance	No break, chip, crack or permanent deformation

**S-720.06.5.2--Class 2 Markers.** Class 2 non-reflective jiggle markers shall consist of a heat-fired, vitreous, ceramic base, and a heat-fired, opaque, glazed surface to produce the properties required in these specifications. The bottom of the marker shall not be glazed. The markers shall be produced from any suitable combination of intimately mixed clays, shales, talcs, flints, feldspars, or other inorganic material which will meet the properties herein required. The markers shall be thoroughly and evenly matured and free from defects which affect appearance or serviceability.

Non-reflective markers shall conform to the following finish and testing requirements:

The top surface of the marker shall be in reasonably close conformity with the configuration shown on the plans. All edges shall be rounded and any change in curvature shall be gradual. The top and sides shall be smooth and free of mold marks, pits, indentations, air bubbles, or other objectionable marks or discolorations. The base of all markers shall be flat (the deviation from a flat surface shall not exceed 0.05 inch) and free from gloss glaze or substances that may reduce its bond to the adhesive.

All tests shall be performed in accordance with Mississippi Test Method: MT-17, which will be on file in the MDOT Materials Division.

<u>Test</u>	<u>Requirement</u>
Glaze thickness	0.005 inch min.
Moh Hardness	6 min.
Directional reflectance (Type A, white markers only)	
Glazed Surface	75 min.
Body of Marker	70 min.
Yellowness Index (Type A, white markers only)	
Glazed Surface	0.07 max.
Body of Marker	0.12 max.
Color (Type AY, yellow markers only), FHWA Highway Yellow Color Tolerance Chart	PR Color # 1
Autoclave	Glaze shall not spall, Craze, or peel
Compressive Loading	750 pounds min.
Water Absorption	2.0% max.

**S-720.06.6--Reflective Pavement Markers.** Reflective pavement markers shall be listed on MDOT's "Approved Sources of Materials" and shall meet the applicable requirements of ASTM Designation: D 4280.

**S-720.06.7--Adhesive for Pavement Markers.**

**S-720.06.7.1--General Requirements.** The adhesive shall be an asphaltic or thermoplastic material suitable for bonding pavement markers to portland cement concrete pavement, hot bituminous pavement and chip-sealed surfaces when the road surface and marker temperatures are in the range of 50°F to 160°F. The composition of the adhesive must be such that its properties will not deteriorate when heated to and applied at temperatures up to 425°F using either air or oil-jacketed melters.

**S-720.06.7.2--Specific Requirements.** In addition to the specific requirements set forth herein, the adhesive shall be listed on MDOT's "Approved Sources of Materials" prior to its use.

**S-720.06.7.3--Packaging and Labeling.** The adhesive shall be packaged in self-releasing cardboard containers which will stack properly. The label shall show the manufacturer, quantity, and lot or batch number. "Adhesive for Pavement Markers" or "Adhesive for Traffic Markers" shall be printed in bold lettering on the label.

**S-720.06.7.4--Sampling.** When required by the Engineer, a minimum of 10 pounds of adhesive per lot or batch received shall be submitted for compliance testing. This may be submitted in the form of an adhesive testing package from each batch or material obtained from a package shipped to the project.

**S-720.06.7.5--Manufacturer's Certified Test Report.** The adhesive will be accepted by a manufacturer's certified test report. The certified test report shall show the test results and shall state that the adhesive represented by the test results meets all the requirements of the contract and has the properties and characteristics as herein specified. It shall be the Contractor's responsibility to furnish three copies of the manufacturer's test report for each batch of adhesive shipped to the project. The Engineer reserves the right to take samples for testing as he deems necessary.

**S-720.06.7.6--Bituminous Adhesive (Standard Type).** The asphaltic material and mineral filler shall comply with the following requirements:

(a) Adhesive Properties:

	<u>Min.</u>	<u>Max.</u>	<u>Method</u>
Softening Point, °F	200	-	ASTM D 36
Penetration @ 77°F	10	20	ASTM D 5
Flow, inch	-	0.2	MT-73
Heat Stability Flow, inch	-	0.2	MT-73
Viscosity, 400°F, Poises	-	75	MT-73
Flash Point, C.O.C., °F	550	-	ASTM D 92

(b) Asphalt properties determined on the filler-free material derived from the extraction and Abson recovery process as explained in Mississippi Test Method MT-73.

	<u>Min.</u>	<u>Max.</u>	<u>Method</u>
Penetration, 100 grams, 5 seconds, 77°F	25	-	ASTM D 5
Viscosity, 275°F, Poises	12	-	ASTM D 2171
Viscosity Ratio, 275°F	-	2.2	MT-73

(c) Filler properties determined using the filler separation technique described in Mississippi Test Method MT-73.

	<u>Min.</u>	<u>Max.</u>	<u>Method</u>
Filler Content, percent by weight	50	75	MT-73
Filler Fineness, percent passing			
Sieve No. 100	100	-	MT-73
Sieve No. 200	90	-	MT-73
Sieve No. 325	75	-	MT-73

**S-720.06.7.7--Flexible Adhesive.** The hot applied flexible pavement marker adhesive shall be a hot melt thermoplastic material capable of bonding the marker without excessive marker movement at hot summer temperatures and remain flexible at winter temperatures. The adhesive shall comply with the following physical requirements when melted in accordance with ASTM Designation: D 3407 and poured into suitable test molds:

<u>Test</u>	<u>Result</u>	<u>Test Method</u>
Penetration, 77°F	25 max.	ASTM Designation: D 5
Softening point	200°F min.	ASTM Designation: D 36
Brookfield viscosity, 400°F	10,000 cp max.	ASTM Designation: D 3236
Ductility @ 77°F, 5 cm/min	15 cm min.	ASTM Designation: D 113
Ductility @ 39.2°F, 1 cm/min	5 cm min.	ASTM Designation: D 113
Asphalt Compatibility	Pass	ASTM Designation: D 5329
Flexibility	Pass at 20°F	Per S-720.06.7.8

**S-720.06.7.8--Test Procedure for Flexibility.**

Sample preparation - One-eighth inch thick steel shims are used to enclose an opening which is one-inch wide and four-inches long on a sheet of release paper or a release treated metal plate. The heated adhesive is poured into the opening until it is slightly overfilled. After one hour of cooling the excess adhesive is trimmed flush with the shims using a hot knife and then the sample is removed from the shims.

Conditioning - The trimmed samples are placed in a freezer maintained at 20  $\pm$ 2°F for a minimum of four hours.

Testing - The conditioned samples are removed from the freezer and immediately bent through an arc of 90 degrees at a uniform rate in 10 seconds (9 degrees per second) over a one inch diameter mandrel. A passing result is one in which no cracking occurs in the test sample. At least two of the three specimens tested must meet the flexibility requirement at 20°F for a passing result.



## **SECTION S-721 - MATERIALS FOR SIGNING**

**S-721.01--General.** All materials included in this section will be conditionally accepted on the basis of the manufacturer's certification of compliance, as specified in S-106.04, except those materials normally tested by MDOT (i.e. concrete, reinforcing steel, timber posts, etc.). The Engineer shall be furnished the original and three copies of the manufacturer's certification. The Engineer reserves the right to test or have tested by a commercial laboratory any material that has been conditionally accepted by certification.

### **S-721.02--Ferrous Materials.**

**S-721.02.1--General.** All welds shall be mechanically cleaned before galvanizing. All ferrous metal except reinforcing steel, and sheet steel unless otherwise specified, shall be zinc-coated (galvanized) by the hot dip method in accordance with AASHTO Designation: M 111 after all fabrication has been completed.

**S-721.02.2--Structural Steel for Sign Supports.** Structural steel used in sign support structures shall be of standard shape. Structural steel pipe per ASTM Designation: A 53 shall be manufactured by the open-hearth or basic oxygen process.

**S-721.02.2.1--Ground Mounted Sign Supports.** Posts shall be provided with "break-away" mountings (as shown on the plans) of the following materials:

Structural steel beams for posts per AASHTO Designation: M 160.

Steel plates for steel beam posts per AASHTO Designation: M 160.

Welded and seamless steel pipe for posts per ASTM Designation: A 53, Type E or S, Grade B, or steel structural tubing per ASTM Designation: A 501.

U-Section posts for supplementary directional signs per S-721.02.3 "Steel Posts for Small Signs" modified as shown on the plans.

Structural steel shapes, bars, and plates used for bracing, framing and other accessories, including base plates for steel posts, per ASTM Designation: A 36.

High strength bolts, nuts, and washers for post bases and for fuse plates per S-717.01.7 and S-810.02.21 modified as shown on the plans.

**S-721.02.2.2--Overhead Sign Supports.** Materials approved for use in the construction of overhead sign supports include the following:

Welded and seamless steel pipe per ASTM Designation: A 53, Type E or S, Grade B or Type F.

Steel structural tubing per ASTM Designation: A 501.

Structural shapes, plates, and bars per ASTM Designation: A 36.

Castings for post, base, and truss flange per AASHTO Designation: M 106, Grade 35018.

Castings for post caps and chord caps per AASHTO Designation: M 105, Class 25 S.

High strength bolts, nuts, and washers for chord connections per S-717.01.7 and S-810.02.21.

Anchor bolts per ASTM Designation: A 307, Grade A.

### **S-721.02.3--Steel Posts for Small Signs.**

**S-721.02.3.1--Material.** The posts shall be of high carbon rail steel ASTM Designation: A 499.

**S-721.02.3.2--Workmanship.** All posts shall be straight with no bending, warping, splits, or breaks.

**S-721.02.3.3--Cross-Section.** The posts shall be "U" section as shown on the plans. The bends in the cross-section of the post must be sharp and well defined, and the radius of the bend shall not be greater than 13/32 of an inch.

**S-721.02.3.4--Weight.** The weight of the posts per linear foot without ground plates, shall be 2.0 pounds for 7-foot and 9-foot lengths and 3.0 pounds for 11-foot and 14-foot lengths with a tolerance of three and one-half percent, or as shown on the plans.

**S-721.02.3.5--Punching.** The posts shall be punched on the center line of the web while hot. Posts of 7-foot to 14-foot lengths shall have 3/8 inch holes one inch apart on centers starting one inch from the top of the posts and extending the full length of the post.

**S-721.02.3.6--Pointing.** The posts shall not be pointed.

**S-721.02.3.7--Ground Plates.** Posts of 7-foot lengths are not required to have ground plates. The distance from the top of the ground plate to the bottom of 9 foot to 11-foot length posts shall be 24 inches. The distance for 12-foot or greater length posts shall be 30 inches.

**S-721.02.4--Reinforcing Steel.** Reinforcing steel used shall conform to S-711 and shall be placed in accordance with S-602.

**S-721.02.5--Bolts, Nuts, Washers, Screws, and other Hardware.** Except as otherwise specified, all bolts, nuts, washers, sheet metal screws, and machine screws shall be coated by the zinc chromate process. The zinc chromate process shall be in accordance with the requirements of ASTM Designation: B633. Bolts shall have a 1/2-inch head and shall meet the requirements of ASTM Designation: A307, Grade A. Nuts shall be self-locking and shall meet the requirements of ASTM Designation: A563. Flat washers shall be installed between the sign support and the self-locking nut and shall meet the requirements of ANSI Designation: B27.2. Sheet metal screws shall meet the requirements of ANSI Designation: B18.6.4. Machine screws shall meet the requirements of ANSI Designation: B18.6.3. Vinyl spacers shall be installed between the bolt head and the sign face and shall meet the following maximum dimensions: 7/8-inch outside diameter by 3/8-inch inside diameter by 1/16-inch thickness.

Post clips used with extruded panel signs shall be cast aluminum per ASTM Designation: B 108, Alloy No. 356.0-T6 or extruded aluminum per ASTM Designation: B 221, Alloy 6063-T6. Unless otherwise specified, all bolts, sheet metal screws, and machine screws used in assembling signs, frames, and post braces, including post clips and panel bolts, shall be in accordance with ASTM Designation: A 307, Grade A.

**S-721.02.5.1--Vandal-Resistant Bolts, Vandal-Resistant Nuts, Nylon Washers and other Hardware.** When Vandal-Resistant Hardware for signs are noted on the plans, all bolts, nuts, washers, sheet metal screws, and machine screws shall be coated by the zinc chromate process. The zinc chromate process shall be in accordance with the requirements of ASTM Designation: B633. Bolts shall be 5/16 inch diameter, 2 1/2 inch long (minimum) carriage bolts, hex bolts or "one-way" bolts. Carriage bolts shall be round headed with a square neck and shall not have any slots or other opening for any type of tool. This square neck shall fit snugly and not move when tightened into the hole in the sign face. Hex bolt and one-way bolt heads shall not be square necked, but shall tighten flat against the sign face. One-way bolts shall be able to be tightened but not loosened by a screw driver. If hex bolts or one-way bolts are used, a nylon washer shall be provided to place between the bolt head and the sign face.

An approved vandal-resistant nut will be required regardless of the type of bolt used. A 5/16 inch inside diameter rustproofed steel, aluminum or approved equal washer shall be provided to place between the post and the vandal-resistant nut. The outside diameter of this washer will be dependent on the type of vandal-resistant nut used.

**S-721.03--Aluminum.** All aluminum shall be free from corrosion, white rust, water stains, dirt, and grease. Fabrication shall be accomplished in a uniform and workmanlike manner. All fabrication, including cutting and punching of holes, shall be completed prior to metal treatment. Sign blanks shall be cut to size and shape and shall be free of buckles,

warps, dents, cockles, burrs, and defects resulting from fabrication. The surface of all sign blanks shall be flat.

All blanks not having corner radii shall have square (90°) corners to facilitate sign fabrication.

All blanks requiring holes shall have "STATE AID PROJECT" debossed on the blank in a location so as not to be covered by the post when erected. The debossed letters shall be not less than 3/8 inch high and shall be approximately 0.006 inch deep so as not to be visible on the other side of the blank.

**S-721.03.1--Sheet Aluminum.** Sheet aluminum or blanks shall meet the requirements of ASTM Designation: B 209, Alloy 6061-T6 or 5052-H38. Gauge, dimension, punching and corner radii shall be in accordance with the plans.

**S-721.03.2--Extruded Signs.** Extruded sign panels, extruded moldings, and extruded post clips shall meet the requirements of ASTM Designation: B 221, Alloy 6063-T6. Sections and dimensions shall be as shown on the plans. The panel shall be of the butt type, designed to withstand a wind pressure of 50 pounds per square foot. All panels shall be flat and straight within commercial tolerances as established by the aluminum industry. Extruded sign sections shall be subject to approval by the Engineer. Extruded sign sections shall be provided with slotted bolt holes. Sign moldings and post clips shall be designed for the sign panel section with which it is used. Sign moldings shall be anchored to the sign panels by means of aluminum pull-through rivets or self tapping screws.

**S-721.03.3--Overhead Sign Support Material.** Material approved for use in the construction of Overhead Sign Supports include the following:

Extruded structural tube and pipe per ASTM Designation: B 221, B 241 or B 429, Alloy 6061-T6.

Extruded structural tube and pipe per ASTM Designation: B 221, B 241 or B 429, Alloy 6063-T6.

Structural shapes per ASTM Designation: B 308, Alloy 6061-T6.

Sheet and plate per ASTM Designation: B 209, Alloy 6061-T6.

Castings for post and chord caps per ASTM Designation: B 26, Alloy No. 356.0.

Base and filler metals for welding shall be as listed below:

<u>BASE</u> <u>METAL ALLOYS</u>	<u>FILLER</u> <u>METAL ALLOYS</u>
6061-T6 to 6061-T6	ER-5556
6063-T6 to 6061-T6 or 6063-T6	ER-4043, ER-5356 or ER-5556

**S-721.04--Concrete.** Unless otherwise specified, concrete shall be Class B. Composition, manufacture, and placement shall be in accordance with S-601.

**S-721.05--Colors and Paint.** All colors for signs shall match FHWA Specifications for standard highway sign colors. The molding which is attached to the extruded panel signs shall be painted with a semi-gloss baking enamel meeting Federal Specification TT-E-529a.

Aluminum paint shall conform to S-710.02.1. Transparent and black opaque process colors used in silk screening shall be that or equal to that recommended by the manufacturer of the retroreflective sheeting, and shall match FHWA Specifications for standard highway sign colors. Toning of certain colors for adjustment in hue shall be accomplished in accordance with the recommendations of the manufacturer of the process paste.

**S-721.06--Reflective Sheeting.**

**S-721.06.1--General.** Retroreflective sheeting materials shall comply with all applicable requirements of ASTM Designation: D 4956, except as specifically modified herein, and be listed on MDOT's "Approved Sources of Materials".

Reflective sheeting shall be one of the following types.

**Type III.** A high-intensity retroreflective sheeting. This shall be an encapsulated glass-bead or unmetallized microprismatic retroreflective material. This sheeting shall have a protected, pre-coated, pressure-sensitive adhesive backing.

**Type VII.** A super high-intensity retroreflective sheeting. This shall be an unmetallized microprismatic retroreflective material. This sheeting shall have a protected, pre-coated, pressure sensitive adhesive backing.

Type VIII. A super high-intensity retroreflective sheeting. This shall be an unmetallized microprismatic retroreflective material. This sheeting shall have a protected, pre-coated, pressure sensitive adhesive backing.

Type IX. A very-high intensity retroreflective sheeting. This shall be an unmetallized, microprismatic retroreflective material. This sheeting shall have a protected, pre-coated, pressure sensitive, adhesive backing.

All other retroreflective sheeting shall be as shown in the plans.

**S-721.06.2--Performance Requirements.** The retroreflective sheeting shall have the following minimum brightness values at 0.2° and 0.5° observation angle, in addition 1.0° for Type IX sheeting, expressed as average candelas per footcandle per square foot of material.

Sheetings and inks processed and applied in accordance with the manufacturer's recommendations, shall perform effectively for the number of years stated below. The sheeting will be considered unsatisfactory if it has deteriorated due to natural causes to the extent that: (1) the sign is ineffective for its intended purpose when viewed from a moving vehicle under normal day and night driving conditions or (2) the coefficient of retroreflection is less than the minimum specified for that sheeting during the periods listed below. For screen printed transparent colored areas on white sheeting, the coefficients of retroreflection shall not be less than 70% of the values for the corresponding color in the table.

Type III Sheeting Retain 85% of initial values listed in Table 1 through 7 years  
Retain 80% of initial values listed in Table 1 between 7 & 10 years

Type VII Sheeting Retain 85% of initial values listed in Table 2 through 7 years  
Retain 80% of initial values listed in Table 2 between 7 & 10 years  
Retain 50% of initial values listed in Table 2 through 3 years for  
Fluorescent Orange

Type VIII Sheeting Retain 85% of initial values listed in Table3 through 7 years  
Retain 80% of initial values listed in Table 3 between 7 & 10 years  
Retain 50% of initial values listed in Table 3 through 3 years for  
Fluorescent Orange  
Retain 80% of initial values listed in Table 3 through 7 years for  
Fluorescent Yellow/Green & Fluorescent Yellow

Type IX Sheeting Retain 85% of initial values listed in Table 4 through 7 years  
 Retain 80% of initial values listed in Table 4 between 7 & 10 years  
 Retain 80% of initial values listed in Table 4 for 7 years for  
 Fluorescent Yellow/Green & Fluorescent Yellow

### MINIMUM COEFFICIENTS OF RETROREFLECTION

Candela per foot candle per square foot ( cd/ft/ft<sup>2</sup>)

Per ASTM Designation: E 810

**TABLE 1**  
**Type III Sheeting**

Observation	Entrance	Sheeting Color						
Angle (°)	Angle (°)	White	Yellow	Orange	Green	Red	Blue	Brown
0.2	- 4	250	170	100	45	45	20	12
0.2	+30	150	100	60	25	25	11	8.5
0.5	- 4	95	62	30	15	15	7.5	5.0
0.5	+30	65	45	25	10	10	5.0	3.5

**TABLE 2**  
**Type VII Sheeting**

Observation	Entrance	Sheeting Color						
Angle (°)	Angle (°)	White	Yellow	Green	Red	Blue	Brown	Fluorescent Orange
0.2	- 4	750	560	75	150	34	23	200
0.2	+30	430	320	43	86	20	10	85
0.5	- 4	240	180	24	48	11	8	90
0.5	+30	135	100	14	27	6.0	4	50

**MINIMUM COEFFICIENTS OF RETROREFLECTION**  
Candela per foot candle per square foot (cd/ft<sup>2</sup>)

**TABLE 3**  
Type VIII Sheeting

Observation Angle (°)	Entrance Angle (°)	White	Yellow	Green	Red	Blue	Brown	Fluorescent Orange	Fluorescent Yellow/Green	Fluorescent Yellow
0.2	-4	700	525	70	105	42	21	200	480	375
0.2	+3	325	245	33	49	20	10	85	240	170
0.5	-4	250	190	25	38	15	7.5	90	235	165
0.5	+3	115	86	12	17	7	3.5	50	110	85

**TABLE 4**  
Type IX Sheeting

Observation Angle (°)	Entrance Angle (°)	White	Yellow	Green	Red	Blue	Fluorescent Yellow/Green	Fluorescent Yellow
0.2	-4.0	380	285	38	76	17	325	240
0.2	+30.0	215	162	22	43	10	205	150
0.5	-4.0	240	180	24	48	11	240	165
0.5	+30.0	135	100	14	27	6.0	110	75
1.0	-4.0	80	60	8	16	3.6	65	45
1.0	+30.0	45	34	4.5	9	2.0	35	25



**S-721.06.3--Certification.** The Contractor shall require the supplier to furnish certified evidence and/or samples to the Engineer showing conformance to these requirements. Manufacturer's warranties or guarantees provided as customary trade practice shall be furnished the Engineer.

**S-721.06.4--Color.** Reflective sheeting shall meet the color requirements of ASTM Designation: D 4956. See Table 5 below for color specifications for fluorescent yellow green, fluorescent orange, and fluorescent yellow sheeting.

**TABLE 5**  
**Color Specification Limits for New Sheeting - Daytime**

Color	Chromaticity Coordinate		Chromaticity Coordinate		Chromaticity Coordinate		Chromaticity Coordinate		Total Luminance Factor Limit
	1		2		3		4		
	x	y	x	y	x	y	x	y	<u>Min.</u>
Fluorescent Yellow Green	0.387	0.610	0.460	0.540	0.438	0.508	0.376	0.568	60%
Fluorescent Orange	0.562	0.350	0.645	0.355	0.570	0.429	0.056	0.404	30%
Fluorescent Yellow	0.521	0.424	0.577	0.442	0.479	0.520	0.454	0.491	40%

**S-721.06.5--Adhesive.** The retroreflective sheeting shall include a pre-coated pressure sensitive adhesive, as referenced in ASTM Designation: D 4956, Class I, applied without the necessity of additional adhesive coats on the retroreflective sheeting or application surface.

The Class I adhesive shall be a pressure sensitive adhesive of the aggressive tack type requiring no heat solvent or other preparation for adhesion to smooth clean surfaces.

The protective liner attached to the adhesive shall be removed by peeling without soaking in water or other solutions and shall be easily removed after accelerated storage for four hours at 160°F under a weight of 2.5 pounds per square inch.

**S-721.06.6-Blank.**

**S-721.07--Delineators.** Delineators shall consist of encapsulated lens reflective sheeting of the specified colors applied to sheet metal with mechanical equipment in a manner specified by the sheeting manufacturer. The sheet metal shall be the same as that used for small sheet signs as required under S-721.03.1.

**S-721.07.1--Flexible Posts.** Flexible posts for delineators shall be composed of high impact fiberglass reinforced composite, engineering blended plastic or thermosetting polymers which is reasonably unaffected by long term U.V. exposure. Flexible posts for delineators must be one from MDOT's "Approved Sources of Materials". Prior to use, the Contractor shall furnish the Engineer three copies of the manufacturer's certification for each shipment stating that the material furnished is of the same composition as that originally approved by the MDOT and that the material has not been changed or altered in any way.

**S-721.07.1.1--Performance Testing for Flexible Posts.**

**S-721.07.1.1.1--Impact Resistance.** The post must be self erecting after withstanding 10 vehicle impacts at temperatures of 0°F or above without complete loss of serviceability. The impacts shall be made at an impact angle of  $25 \pm 5^\circ$  with a sedan at 35 mph.

**S-721.07.1.1.2--Heat Resistance.** A post shall be conditioned a minimum of two hours in an oven at  $115^\circ \pm 3^\circ\text{F}$ . The conditioned post shall be capable of straightening itself within 10 seconds when bent  $90^\circ$  at or near midpoint for each of four bends. The test on each post shall be completed within two minutes after removal from the oven. The post shall be bent in the direction to form a  $90^\circ$  angle on the convex side of the post.

**S-721.07.1.1.3--Cold Resistance.** A post shall be conditioned a minimum of two hours at  $-5^\circ \pm 3^\circ\text{F}$  in an environmentally controlled test chamber. Testing shall be performed in the environmental chamber. The conditioned post shall not be adversely effected when bent at or near midpoint to a  $90^\circ$  angle formed on the convex side of the post. The post shall return to its original shape within 60 seconds for each of four separate bends.

**S-721.07.1.1.4--Color Fastness.** The post materials shall be exposed for 1000 hours in an Atlas Type B or BH Xenon Arc Weatherometer per ASTM Designation: G 26 with no significant yellowing or darkening.

**S-721.07.1.2--Acceptance Procedure.** Flexible posts for delineators must be one from MDOT's "Approved Sources of Materials". Prior to use, the Contractor shall furnish the Engineer three copies of the manufacturer's certification for each shipment stating that the material furnished is of the same composition as that originally approved by MDOT and that the material has not been changed or altered in any way.

**S-721.08--Removable Copy.** Removable copy shall include letters, numerals, symbols, and borders. All designs shall conform to the MUTCD. All removable copy will be attached to the sign face from the front by means of a huck or a cherry rivet gun and aluminum pull-through rivets without the use of clips. Removable copy shall consist of encapsulated lens retroreflective sheeting which has been carefully selected by the manufacturer for uniformity of day and night appearance and applied to flat aluminum backing. The backing shall be a minimum of .032" thick aluminum sheet as per ASTM Designation: B 209, alloy 3003-H14. The metal treatment shall be the same as that for aluminum sheet.

**S-721.09--Timber Sign Posts.** The posts shall conform to the requirements set forth in S-712.01.2, except that the preservative shall conform with S-718.04.3 or S-718.04.4.

**S-721.10--Direct Applied Copy.** Direct applied copy which is to be provided on guide directional signs, ground mounted or overhead, shall be directly applied to the sign face. Direct applied copy shall include letters, numerals, symbols and borders. All designs shall conform to the MUTCD. All direct applied copy shall be attached to the sign face by means of pressure sensitive adhesive meeting the requirements of S-721.06.5. Direct applied copy shall consist of encapsulated lens retroreflective sheeting meeting the requirements of S-721.06.

All signs shall be delivered to the site of their erection in one piece with all bolts, rivets, moldings, extrusions, copy, and other required appurtenances thereto attached, complete and ready to be mounted to the sign support structure. Any required supplemental or temporary supports required for stability during transport shall be firmly attached but easily removed prior to erection.

## **SECTION S-722 - GEOGRIDS**

### **S-722.01--Geogrids.**

**S-722.01.1--General.** A geogrid is defined as a geosynthetic formed by a regular network of integrally connected elements with apertures greater than 0.25 inch to allow interlocking with surrounding soil, rock, earth and other surrounding materials to function primarily as reinforcement.

The geogrid shall be creep tested in accordance with ASTM Designation: D 5262. The long term design load that shall be reported for design use, shall be that load at which no more than 10% strain occurs over a 100-year design life of the geogrid, as calculated from tests run on representative samples for no less than 10,000 hours. The long term design load shall be reported unfactored, as the AASHTO strength reduction - Durability and Installation, and safety factors - will be considered by the MDOT Geotechnical Branch on a site specific design basis.

The geogrid shall meet the physical requirements of Table II for the type shown on the plans and shall be selected from MDOT's list of "Approved Sources of Materials."

The geogrid shall be mildew resistant and inert to biological degradation and naturally encountered chemicals, alkalis and acids. The geogrid shall contain stabilizers and/or inhibitors, or a resistance finish or covering to make it resistant to deterioration from direct sunlight, ultraviolet rays, and heat.

**S-722.02--Marking, Shipment and Storage.** Each roll or container of geogrid shall be visibly labeled with the name of the manufacturer, trade name of the product, lot number, and quantity of material. In addition, each roll or container shall be clearly tagged to show the type designation that corresponds to that required by the plans. During shipment and storage the geogrid shall be protected from direct sunlight, and temperatures above 120°F or below 0°F. The geogrid shall either be wrapped and maintained in a heavy duty protective covering or stored in a safe enclosed area to protect from damage during prolonged storage.

**S-722.03--Manufacturer's Certification.** The Contractor shall furnish the Engineer three copies of the manufacturer's certified test reports indicating that the geogrid furnished conforms to the requirements of the specifications and is of the same composition as that originally approved by MDOT.

**S-722.04--Acceptance Sampling and Testing.** Final acceptance of each shipment will be based upon results of tests performed by MDOT or other approved laboratory on verification samples submitted from the project, as compared to the manufacturer's certified test reports. The Engineer will select one roll or container at random from each shipment for sampling. A sample extending full width of the randomly selected roll or container and being at least five (5) square yards in area will be obtained and submitted by the Engineer. The sample from each shipment shall be provided at no cost to the Project.

**TABLE II  
GEOGRIDS**

**MINIMUM AVERAGE ROLL VALUE**

Physical Properties	Type Designation						Test Method
	I	II	III	IV	V	VI	
Long Term Design Load, pounds per foot, Machine Direction	250	500	750	1500	2500	3500	ASTM Designation: D-5262
Minimum Ultimate Tensile Strength, pounds per foot, Machine Direction	500	1000	1500	3000	5000	7000	ASTM Designation: D-4595
Open Area, percent	70	70	50	50	50	50	Direct Measurement

**Sections S-723 thru S-799--Blank**



<u>Section</u>	<u>Page</u>
S-800 - BRIDGES AND STRUCTURES	8-1
S-801 - EXCAVATION AND FILL	8-1
S-802 - SHEET PILING	8-6
S-803 - DEEP FOUNDATIONS	8-8
S-804 - CONCRETE BRIDGES AND STRUCTURES	8-51
S-805 - REINFORCEMENT	8-109
S-806 - PRECAST CONCRETE BRIDGES	8-113
S-807 - thru S-809 - Blank	8-122
S-810 - STEEL STRUCTURES	8-123
S-811 - BRONZE OR COPPER-ALLOY BEARING AND EXPANSION PLATES	8-155
S-812 - STEEL GRID FLOORING	8-156
S-813 - RAILING	8-159
S-814 - PAINTING METAL STRUCTURES	8-162
S-815 - RIP RAP AND SLOPE PAVING	8-167
S-816 - MAINTENANCE PAINTING OF METAL STRUCTURES	8-172
S-817 - thru S-819 - Blank	8-175
S-820 - TIMBER STRUCTURES	8-176
S-821 - Blank	8-183
S-822 - NEOPRENE EXPANSION JOINTS	8-184
S-823 - thru S-899 - Blank	8-184





**SECTION S-801 - EXCAVATION AND FILL**

**S-801.01--Description.** Foundation excavation shall include the removal of all material, of whatever nature, necessary for the construction of foundations and substructures of bridges in accordance with the plans or as directed by the Engineer. When not shown as a pay item, it shall include the furnishing of all necessary equipment and the construction of all cribs, cofferdams, dewatering, etc. necessary for execution of the work. It shall also include the subsequent removal of cofferdams and cribs and the placement of all necessary backfill as hereinafter specified. It shall also include the disposal of excavated material, which is not required for backfill or other specified usage, in a manner and in locations that will not be unsightly or affect the carrying capacity of the channel or other related drainage.

Unless a greater area is necessary for construction, the bridge site shall be the area defined in S-101.02. Clearing and grubbing shall be in accordance with the provisions of S-201.04.

All substructures, where practicable, shall be constructed in open excavation, and where necessary, the excavation shall be shored, braced, or protected by cofferdams in accordance with approved methods. When footings can be placed in the dry without the use of cribs or cofferdams, back forms may be omitted with the approval of the Engineer and the entire excavation filled with concrete to the top of the footing. The additional concrete required shall be placed at the expense of the Contractor.

**S-801.02--Preservation of Channel.** Unless otherwise specified, no excavation shall be made outside of cribs, cofferdams, or sheet piling, and the natural stream bed adjacent to the structure shall not be disturbed without permission of the Engineer. If any excavation or dredging is made at the site of the structure before cribs or cofferdams are in place, the Contractor shall, without extra compensation and after the foundation base is in place, backfill all such excavation to the original ground surface or river bed with material satisfactory to the Engineer. Material deposited within the stream area from foundation or other excavation or from the filling of cofferdams shall be removed and the stream area freed from obstruction thereby.

**S-801.03--Depth of Footings.** The elevations shown on the plans for bottoms of footings shall be considered as approximate, and the State Aid Engineer may order, in writing, changes in dimensions or elevations necessary for a satisfactory foundation.

**S-801.04--Preparation of Foundations for Footings.** All rock or other hard foundation material shall be cut to a firm surface, either level, stepped, or roughened as may be directed by the Engineer, and then cleaned of all loose material. All seams shall be cleaned out and filled with concrete, mortar, or grout.

Excavation and preparation of foundations for footings for box bridges shall be in accordance with the provisions of S-206.

**S-801.05--Cofferdams and Cribs.**

**S-801.05.1--General.** Cofferdams and cribs shall be safely designed and constructed to adequate depths and heights, and be made as water-tight as is necessary for the proper performance of the work to be done inside them. In general, the interior dimensions of cofferdams and cribs shall be sufficient to permit construction of forms and the inspection of their exteriors and to permit pumping outside of the forms. Cofferdams or cribs which tilt or move laterally during the process of sinking shall be righted, reset, or enlarged so as to provide the necessary clearance. All corrective work shall be at the expense of the Contractor.

When conditions are encountered which, in the opinion of the Engineer, make it impracticable to dewater the foundation, he may require the construction of a concrete seal of the dimensions necessary, with approval of the State Aid Engineer. The foundation shall then be pumped out and the balance of the masonry placed in the dry. When weighted cribs are employed, and the weight is utilized to partially overcome the hydrostatic pressure acting against the bottom of the foundation seal, special anchorage such as dowels or keys shall be provided to transfer the entire weight of the crib into the foundation seal. During the placing of a foundation seal, the water elevation inside the cofferdam shall be controlled to prevent any flow through the seal, and if the cofferdam is to remain in place, it shall be vented or ported at low water level.

**S-801.05.2--Protection of Concrete.** Cofferdams or cribs shall be constructed so as to protect green concrete against damage from a sudden rising of the stream and to prevent damage to the foundation by erosion. Timber or bracing that will extend into the substructure masonry shall not be left in cofferdams without written permission from the Engineer.

**S-801.05.3--Drawings Required.** The Contractor shall submit to the Engineer for approval two copies of structural design analysis and detail drawings which show his proposed method of constructing the cofferdam. These drawings shall include the types and sizes of sheeting, wales, bracing, and struts, the connections therefor, and the proposed method of installing, sealing, dewatering, cut-off and/or removal. Cofferdam construction shall not start until the State Aid Engineer has returned approved drawings to the Contractor. The cofferdam details submitted for approval shall bear the seal of a Registered Professional Engineer experienced in cofferdam design. Approval of the proposed method of cofferdam construction shall not relieve the Contractor of any of his responsibility for successful completion of the work.

The Registered Professional Engineer shall certify that the actual material and material fabrication used for cofferdam construction are capable of supporting the loads.

When submitting drawings and design data for approval, the Contractor shall list the bent numbers on which he proposes to construct cofferdams.

The Engineer will review and submit to the State Aid Bridge Engineer for his review the Contractor's drawings and, except under unusual circumstances, return the drawings to the Contractor within thirty (30) days of receipt.

**S-801.05.4--Removal.** Unless otherwise provided, cofferdams or cribs with all sheeting and bracing shall be removed after the completion of the substructure. Care shall be taken not to disturb or otherwise injure the finished masonry.

**S-801.06--Pumping.** Pumping from the interior of a foundation enclosure shall be done so as to preclude the possibility or movement of water through fresh concrete. There shall be no pumping during the placing of concrete or for a period of at least twenty-four (24) hours thereafter, unless it can be done from a suitable sump separated from the concrete work by a water-tight wall or other effective means.

Pumping to dewater a sealed cofferdam shall not commence until the seal has set sufficiently to withstand the hydrostatic pressure.

**S-801.07--Inspection.** After each excavation is completed, the Contractor shall notify the Engineer, and no masonry shall be placed until the Engineer has approved the depth of the excavation and the character of the foundation material.

**S-801.08--Backfill.** No backfill shall be placed against a masonry unit until permission has been given by the Engineer and preferably not until the masonry has been placed at least fourteen (14) days, or until test cylinders show the strength to be twice the working stress used in the design.

All material used for backfill shall meet the requirements of S-203.09.3.3.

Adequate provision shall be made for thorough drainage of all backfilling. French drains shall be placed at weep holes as specified.

All excavated space not occupied by the permanent structure shall be backfilled to the surface of the surrounding ground or to the typical section indicated on the plans or established, whichever is lowest. All backfill shall be thoroughly compacted and sufficient allowance shall be made for settlement.

Where it provides drainage, bearing strength, or lateral support to the permanent construction, all backfilling shall be performed in accordance with the provisions of S-203.09.3.3.

In general, the top surface of the backfilled area shall be neatly graded to the section indicated on the plans or as established.

**S-801.09--Approach Embankment.** When approach embankments are required, they shall be constructed and will be paid for in accordance with S-203.

### **COMPENSATION**

**S-801.10--Method of Measurement.** Foundation excavation, satisfactorily performed, will be measured by the cubic yard in the original position with dimensions determined as follows:

- (1) Bottom - the elevation of the bottom of the footing, seal, or web wall as applicable.
- (2) Top - the elevation of the original ground or graded section, whichever is lower.
- (3) Sides - vertical planes no more than 18 inches outside the outer edges shown on the plans (or directed) for the footing, seal, or web wall.

The measurement will not include water or other liquids, but will include mud, muck, and other similar semi-solids.

Extra depth excavation, made necessary by the Engineer establishing the elevation of the footing or seal below the elevation shown on the plans, will be measured in cubic yards in its original position. This volume will be determined by multiplying the area of the excavation, as determined above, by the distance the footing or seal is lowered. This volume will be divided into the applicable increments indicated in S-801.11.

When the material yielded from foundation excavation is insufficient, or is determined to be unsuitable for backfill material, required backfill material ordered by the Engineer will be included in the measurement for the applicable item of excavation under S-203. Other materials shown on the plans or ordered and used as backfill materials will be measured in accordance with the provisions governing the material specified.

Unless otherwise specified, haul of foundation excavation and materials for backfill will not be measured for separate payment.

When shown as a pay item, cofferdams will be measured as a lump sum quantity. This lump sum quantity includes all cofferdams required for footing construction.

Measurement for progress estimates will be based on the number of cofferdams completed as compared to the total number listed by the Contractor in accordance with S-801.05.3.

**S-801.11--Basis of Payment.** Foundation excavation measured to the elevation of the bottom of the footing as shown on the plans, will be paid for at the contract unit price per cubic yard.

Extra depth excavation, required below the footing or seal elevation shown on the plans, will be paid for per cubic yard in accordance with the following schedule:

Established Elevation of the Footing Below the Elevation Shown on the Plans	Payment (percent of Contract Price)
0.00' to 1.99'	100%
2.00' to 3.99'	120%
4.00' to 5.99'	150%
6.00' to 7.99'	165%
8.00' to 9.99'	195%
10.00' or more	230%

Selected backfill material, shown on the plans or ordered by the Engineer, to be obtained from sources other than from foundation excavation will be paid for at the contract unit price for the material specified and used.

All required cofferdams or cribs shown as pay items will be paid for at the contract lump sum price.

The prices thus paid shall be full compensation for completing the work specified.

All work required under this section for which no pay items are included in the proposal will not be measured for separate payment, compensation therefore shall be considered as included in the prices and payment for bid items.

Payment will be made under:

**S-801-A:** Foundation Excavation for Bridges - per cubic yard

**S-801-B:** Cofferdams - Lump Sum

**S-802.01--Description.** This work consists of furnishing and installing permanent sheet piling as shown on the plan, or ordered by the Engineer to be left in place as part of the finished structure. Except where indicated as a pay item in the plans, no compensation will be allowed for furnishing and installing temporary sheet piling and appurtenances. Temporary sheet piling will ONLY be paid for when a pay item is included in the plans.

**S-802.02--Material.**

**S-802.02.1--Concrete Sheet Piles.** Concrete sheet piles shall be in accordance with the detailed design. The requirements governing their manufacture and installation shall conform, in general, to those governing concrete bearing piles.

**S-802.02.2--Steel Sheet Piles.** Steel sheet piles shall conform to the requirements of S-719.05 and shall be of the type and weight specified. The piles, when in place in the completed structure, shall be practically water-tight at the joints. Painting of steel sheet piles shall conform to S-814.

**S-802.03--Construction Methods.** Construction methods for sheet piling shall conform to the applicable requirements of S-803.

Temporary sheet piling shall be a steel sheet pile retaining wall constructed as indicated on the plans. Painting of the sheet piling will not be required. The sheet piling shall be removed upon completion of the work and the area shall be restored as directed by the Engineer.

**COMPENSATION**

**S-802.04--Method of Measurement.** Permanent sheet piling will be measured for payment in square feet, on the basis of the piles driven as approved by the Engineer. Cut-offs will be deducted from the measurement. Unless shown as a pay item, no measurement for extra compensation will be made for such temporary sheet piling required for foundations and in conjunction with bridge excavation not designated for payment.

Temporary steel sheet piling will be measured by the square foot, on the basis of the piles driven as approved by the Engineer. Temporary steel sheet piling will only be measured for payment when a pay item is included in the plans.

**S-802.05--Basis of Payment.** Permanent and temporary sheet piling, measured as prescribed above, will be paid for by the square foot, which price shall be full compensation for completing the work.

Payment will be made under:

**S-802-A:** Permanent Steel Sheet Piling - per square foot

**S-802-B:** Permanent Concrete Sheet Piling - per square foot

**S-802-C:** Temporary Steel Sheet Piling - per square foot

**S-803.01--General.**

**S-803.01.1--Description.** This work consists of furnishing and installing deep foundations in accordance with these specifications and in reasonable conformance with the lines, elevations, and spacings shown on the plans. It shall also consist of furnishing all required labor, tools, and equipment to determine the bearing value of the deep foundation by static load testing, by dynamic load testing, and/or by driving of the specified test piles.

**S-803.01.2--Order Lists for Deep Foundations.** Lengths found in the plans are estimated lengths for bid purposes. Unless otherwise specified or authorized in writing by the State Aid Bridge Engineer, all permanent deep foundations shall be installed within the prescribed tolerances specified herein and to the depths and/or lengths indicated on the itemized Order List furnished by the Engineer. The Order List shall be furnished after bearing has been verified either through static load testing, dynamic load testing, and/or driving of the specified test piles.

In general the penetration for any pile shall be not less than five feet in hard material and not less than one-third the length of the pile nor less than twenty (20) feet in soft material. For foundation work, no piling shall be used to penetrate a very soft upper stratum overlying a hard stratum unless the piles penetrate the hard material a sufficient distance to rigidly fix the ends.

The Contractor shall furnish or install driven piles and/or drilled shafts in accordance with an itemized list furnished by the Engineer. The Order List will show the required length of the piles or drilled shafts for each bridge bent or footing.

**S-803.02--Materials.** All materials shall conform to the applicable requirements set forth in S-710, S-711, S-719, S-804, and S-814.

Driven piles shall conform to all applicable requirements set forth in S-719 and the plans. Paint for steel piles or steel shells shall conform to the applicable requirements of S-710 and S-814.

Drilled shaft concrete shall conform to the requirements of S-804 for Class "DS" concrete. All reinforcing steel shall conform to the requirements of S-711 of the Specifications.

**S-803.03--Construction Requirement.** This work shall consist of furnishing all labor, materials, equipment and services necessary to install driven piles of the prescribed type in accordance with these specifications and in conformance with the lines, elevations, and spacings shown on the plans.



This work shall also consist of furnishing all labor, materials, equipment and services necessary to perform all operations to complete the drilled shaft installations in accordance with these specifications and with the details and dimensions shown on the plans. Drilled shafts shall consist of reinforced or nonreinforced concrete with or without concrete bell footings.

**S-803.03.1--Driven Piles.**

**S-803.03.1.1--General.** Unless otherwise specified or authorized by the Engineer, all permanent production piles shall be driven in a continuous operation, to the full lengths indicated on the itemized order list furnished by the State Aid Bridge Engineer.

**S-803.03.1.2--Accuracy of Installation.** Driven piles in trestle bents shall be driven to within a tolerance of 1/4 inch per foot from the vertical or from the batter shown on the plans. Piles to be incorporated into a cap or footing shall not be out of the position shown on the plans by more than six inches. In all cases, piles shall be driven so that they will not be excessively stressed to place them in the proper location in the cap or footing. Excessive manipulation of the piles will not be permitted, and the Contractor shall redrive or use other satisfactory methods to avoid such manipulations. No shimming on tops of piles will be permitted.

**S-803.03.1.3--Extensions, Build-ups and Splices.** If determined by the Engineer to be necessary, production piles that are extended below cut-off shall be extended, built-up, or spliced in accordance with the plans to the extent established by the State Aid Bridge Engineer. Extensions or build-ups will not be measured for payment as such, but will be included in the total length of piling in the finished structure.

**S-803.03.1.4--Cut-Offs.** If it is determined by the Engineer that the pile has reached practical refusal above pile cut-off elevation but below the prescribed minimum tip elevation shown in the plans then the Contractor will be allowed to cut off the pile at the cut-off elevation.

**S-803.03.1.5--Driven Pile Types.** Driven piles shall be of the type listed below unless otherwise specified in the plans.

**S-803.03.1.5.1--Concrete Piles.** Concrete piles shall be the size and shape specified. Reinforcement, unless otherwise designated, shall have a clear distance of at least two inches from the face of the pile. When the piles are for use in salt water or alkali soils this clear distance shall be at least three inches.

**S-803.03.1.5.2--Steel Piles.** Full-length piles shall be used unless splicing is approved in writing by the State Aid Bridge Engineer. When permitted, splicing shall be in accordance with the notes and details shown on the plans. When authorized, splices will be paid for in accordance with S-803.05.8.

**S-803.03.1.5.3--Timber Piles.** Specified timber piles or timber piles used for temporary construction shall meet the requirements set forth in S-820.

**S-803.03.1.5.4--Special Piles.** Piles not of the type specified above, but called for in the plans or additional specifications shall meet the general requirements contained therein.

**S-803.03.1.6--Preparation for Driving.**

**S-803.03.1.6.1--Excavation.** When a pile cap is located below the ground line, piles shall not be driven until the required excavation is completed. All material forced up between the piles shall be removed to the correct elevation at the Contractor's expense before concrete for the foundation is placed.

**S-803.03.1.6.2--Pile Cushions.** Suitable cushioning material shall be used between the driving helmet and the top of the pile. This is especially critical for concrete piles. The Contractor should submit the type material, cross-sectional area and total thickness of the pile cushion. This information shall be submitted to the Engineer for approval prior to driving piling. The pile cushion shall be approved with the pile driving system and is subject to satisfactory field performance.

**S-803.03.1.7--Method of Installation and Driving System.**

**S-803.03.1.7.1--General.** The pile driving system shall be defined as all equipment necessary to install the specified piles to the required minimum tip elevations specified in the plans. The pile driving system shall include the pile hammer, hammer leads, followers, water jets, drilling equipment for pre-formed pile holes, and templates, if necessary.

**S-803.03.1.7.2--Submittal of Pile Driving System Data.** The Contractor shall submit to the Engineer all technical specifications and operating instructions relating to the pile driving system that is to be used to drive the piling. The Contractor shall submit this data to the Engineer at the pre-construction conference or no later than 14 days prior to the anticipated driving date. The Contractor will not be allowed to install any piling until the driving system has been approved by the Engineer.

The Engineer will notify the Contractor of any additional information required and/or changes that may be necessary to meet the project requirements. Any parts of the driving system that are unacceptable will be rejected and the Contractor will submit changes. Review of these changes will be completed within seven (7) days and the Contractor notified of their acceptance or rejection.

All production piles shall be driven with the hammer bearing the same Serial Number originally submitted to the Engineer and used to drive the test piles. In the event multiple hammers of differing type are used on the same bridge, the Contractor shall submit to the Engineer for approval, data for each hammer and specify the bridge bents in which each hammer will be used. This will allow the Engineer the opportunity to develop appropriate driving and acceptance criteria specific to each hammer.

A different pile driving system, modifications to the existing system, or different pile installation procedures shall be proposed by the Contractor if problems in driving the piling are encountered. All approvals are conditional and subject to trial and satisfactory performance in the field. Unless otherwise permitted by the State Aid Bridge Engineer in writing, test piles and permanent piles shall be driven with the approved driving system.

**S-803.03.1.7.3--Pile Hammers.** Piles may be driven with an approved single-acting or double-acting pile hammer in combination with water jets or pre-formed pile holes. The pile driving system shall be constructed so as to afford freedom of movement of the pile hammer and to drive the piles to the required depth within the tolerances specified without undue injury to the piles.

The pile hammer shall be in good working condition and produce the energy required to install piles to the depth or penetration required in the plans. Single or double-acting Steam/Air, Diesel/Internal Combustion, or Hydraulic hammers may be submitted for review and approval.

In no case shall a gravity or drop hammer be used to drive concrete piles. A drop hammer may be used to install timber or steel piles when approved by the Engineer.

**S-803.03.1.7.4--Driving Appurtenances.**

**S-803.03.1.7.4.1--Pile Hammer Leads.** Either fixed leads or swinging leads may be used. Swinging leads shall be used in combination with rigid templates approved by the Engineer. Battered piles shall be driven in inclined leads or multiple rigid templates capable of holding the pile in the proper position during driving.

**S-803.03.1.7.4.2--Pile Cushions.** Suitable cushioning material shall be used between the driving cap and the top of the pile. The cushion material shall protect the pile top during driving and shall be constructed such that the hammer energy is uniformly distributed to the pile top. If the cushion material becomes highly compressed, or chars or burns during the driving operations or damage occurs at the pile top, it shall be replaced.

**S-803.03.1.7.4.3--Water Jets.** When required by the Engineer, water jets will be used in conjunction with the pile hammer to install piles to the required depth or penetration called for in the plans. The use of water jets, where the stability of embankments or other improvements would be endangered, will not be permitted. When water jets are used, the number of jets and the volume and pressure of water shall be sufficient to adequately facilitate driving without undue damage to the pile or the soil adjacent to or below the pile. Unless otherwise specified, water jets shall not be used within five feet of the final tip elevation of the pile. In addition, it shall be the Contractor's responsibility to withdraw the water jets sufficiently above the five foot requirement to obtain the specified bearing at the required cut off elevation.

In the event a jetted pile fails to obtain the specified bearing at the required penetration and a determination is made by the Engineer that the Contractor has failed to properly control the jetting operation, the Contractor should submit detailed corrective measures for founding the pile to the Engineer for approval. Any required corrective measures to the pile due to the Contractor's operation shall be performed at no additional cost to the Project.

**S-803.03.1.7.4.4--Followers.** Followers are considered to be part of the driving system and should be included for approval with the pile driving system data.

**S-803.03.1.7.4.5--Pre-formed Pile Holes.** The State Aid Bridge Engineer will make all determinations as to the necessity for pre-formed pile holes and the size and maximum depth of each hole required or permitted.

If it is determined from the Geotechnical Investigation or from the site survey that pre-formed pile holes are necessary, a pay item and estimated quantities will be included on the plans, and the Engineer will furnish the Contractor with an itemized list showing the location, size and bottom elevation of each hole.

If the plans do not specify pre-formed pile holes and the Engineer, with the concurrence of the State Aid Bridge Engineer, determines during construction that subsurface conditions are encountered that necessitate pre-formed pile holes, at certain locations, an adjustment in the contract unit price for furnishing and driving piling at these locations may be made under the provisions of S-104.02.

If in the judgment of the Engineer pre-formed pile holes are not required and the Contractor desires to use them, the Contractor may be permitted to do so under conditions prescribed by the State Aid Bridge Engineer and at no additional cost to the Project.

**S-803.03.1.7.4.6--Additional Equipment.** When a minimum penetration is indicated on the plans and is not obtained by the use of an approved hammer, the Contractor shall provide, with the approval of the Engineer, a heavier hammer or resort to jetting at no additional cost to the Project.

**S-803.03.1.8--Defective Piles.** Prior to driving, piles shall not be subjected to handling that causes damage either through bending, crushing or spalling of concrete, or deformation of the steel. All piles damaged because of internal defects or by improper driving, driven out of the proper location or driven below the specified elevation shall be corrected at the Contractor's expense by one of the following methods approved by the State Aid Bridge Engineer for the pile in question:

- (1) The pile shall be withdrawn and replaced by a new and, if necessary, a longer pile.
- (2) A second pile shall be driven adjacent to the defective or low pile.
- (3) The pile shall be spliced or built up or a sufficient portion of the footing shall be extended to properly embed the pile. All piles pushed up by the driving of adjacent piles or by any other cause shall be driven down to grade.

**S-803.03.1.9--Determination of Bearing Value of Piling.**

**S-803.03.1.9.1--General.** The ability of the pile to transfer load to the ground will be determined to the satisfaction of the Engineer.

**S-803.03.1.9.2--Determination of Bearing Value by Pile Hammer Formulas.** When load testing, either static or dynamic, is not called for in the plans, the safe bearing values will be determined by the following formulas or as directed by the Engineer.

$$P = \frac{2WH}{S+1.0} \quad \text{for drop hammer (timber piles only)}$$

$$P = \frac{2WH}{S+0.5} \quad \text{for drop hammer (steel piles only)}$$

$$P = \frac{2WH}{S+0.2} \quad \text{for single-acting steam/air hammers and open cylinder diesel hammers}$$

$$P = \frac{2H(W+Ap)}{S+0.1} \quad \text{for double-acting steam hammers *}$$

\* In lieu of this formula, the manufacturer's charts for applicable hammer may be used.

Where

- P = safe bearing value in pounds
- W = weight, in pounds, of striking parts of hammer
- H = height of fall in feet
- A = area of piston in square inches
- p = steam/air pressure in pounds per square inch at the hammer
- S = the average penetration in inches per blow for 10 blows for gravity hammers and the last 10 to 20 blows for steam/air hammers

These formulas are applicable for the following conditions only:

- (a) The hammer has a free fall.
- (b) The pile head is not crushed.
- (c) The penetration is reasonably quick and uniform.
- (d) There is no appreciable bounce after the blow.
- (e) A follower is not used.

Where there is appreciable bounce of the hammer, twice the height of the bounce shall be deducted from "H" to determine its value in the formula.

When water jets are used, the bearing value shall be determined by the above formulas from the results of driving after the jets have been withdrawn, or a static or dynamic load test has been conducted.

Formulas for pile hammers not covered herein must be approved by the State Aid Bridge Engineer.

**S-803.03.1.9.3 Thru S-803.03.1.9.3.2.-- Blank**

**S-803.03.1.9.3.3- Restrike of Piling.**

**S-803.03.1.9.3.3.1--General.** This method of bearing determination will only be used **with prior approval** of the State Aid Bridge Engineer. Restrikes shall be performed with a warm hammer operating at normal efficiency. A warm hammer is defined as a hammer that has applied a minimum of 20 blows to another pile or a dummy block immediately before being used in a restrike. The restrike shall consist of striking the pile for 50 blows or until the pile penetrates an additional three inches, whichever occurs first. In the event the pile movement is less than one inch after 15 blows during the restrike, the restrike may be terminated. No payment will be made for this procedure.

**S-803.03.1.9.3.3.2--Blank**

**S-803.03.1.9.3.3.3--Blank**

**S-803.03.1.9.4--Determination of Bearing Value by Static Load Testing.** When called for in the plans or directed by the Engineer, static load testing will be conducted to determine the ultimate bearing capacity of piles. Depending upon the conditions encountered in the field, the State Aid Bridge Engineer may increase or decrease the number of static load tests required.

**S-803.03.1.9.4.1--Blank.**

**S-803.03.1.9.4.2--Conventional Static Load Test.**

**S-803.03.1.9.4.2.1--Loading Test.** Depending upon conditions encountered in the field, the State Aid Bridge Engineer may increase or decrease the number of loading tests required. In the event the number of loading tests are increased from that indicated in the contract, consideration will be given for delays, if any, in the applicable controlling phase of work caused solely by the seven-day or other waiting period required by the Engineer. Any adjustments will be in accordance with S-108.06.

These tests shall, in general, consist of a test load placed on a suitable platform supported by the pile. A suitable apparatus for accurately measuring the test load and the settlement of the pile under each increment of load shall be provided. At the option of the Contractor, hydraulic jacks with suitable yokes, or other suitable hydraulic pressure systems with gages, may be used in lieu of or in combination with platform loading.

**S-803.03.1.9.4.2.2--Methods and Equipment.** Apparatus for measuring the behavior of the pile during the test, whether tested by dead load or hydraulic pressure or combination, shall consist of a measuring frame and two approved dial gage type measuring devices attached to the pile as indicated on the plans. Each gage shall be actuated by its stem or by a stem attachment resting on the beam of the measuring frame. Supports for the measuring frame shall be placed the maximum practical distance from the test pile and the anchor piles. Each dial gage shall be capable of providing measurements to an accuracy of 0.001 inch throughout a movement range of four inches and shall be sensitive to a force of one pound or less. At least one approved standby gage of each type used shall be provided at all times. The Contractor shall furnish a certification of the sensitivity and accuracy of each dial gage through the required range of use. The Engineer may require recertification of a gage at any time there is an indication of inaccuracy. The Contractor shall provide adequate protection from the elements or from other damage to gages and other specified measuring devices during handling, transportation, and use so that inaccurate measurements or delays will not result because of such damage.

**S-803.03.1.9.4.2.3--Platform Method.** When the dead load method for loading of the pile is used, the Contractor shall submit a loading plan and method for measuring the load to the Engineer for approval prior to its use. The method of dead loading shall be such that wind loads will not effect the measured applied load.

Suggested methods for accomplishing this are:

- A. Perform the load test when the wind is calm;
- B. Support the dead load by a system which isolates it from the pile and use the dead load as the reaction device for hydraulic loading as provided herein; or
- C. Any other approved method which will provide accurate measurement of the applied load with adequate protection from wind effects.



**S-803.03.1.9.4.2.4--Hydraulic Method.** When the hydraulic pressure system method for applying the test load is used, the Contractor shall furnish a hydraulic jacking system complete with gages and charts. The system shall include one or more hydraulic jacks in good condition without leaks. The jacks shall be capable of applying the required load and shall have adequate piston travel to compensate for the yield of the reaction facilities and the vertical displacement of the pile being tested.

The pressure gages shall have at least six-inch dials with 14-inch scales and twin-tip pointers or mirrored dials to permit accurate readings or at least eight-inch dials and 18-inch scales, in which case the mirror or twin-tip pointer will not be required. The gage shall accurately reflect the fluid pressure in the system within plus or minus one percent throughout the system capacity. Graduations on the gage shall be such that the applied load can be read directly in increments of two percent or less, or shall be such that when read to the exact graduation and referred to a certified calibration chart will provide a determination of the load being applied within plus or minus one percent. Each gage shall contain a capacity for recalibration to zero at zero pressure.

The complete hydraulic jacking system and gages shall be calibrated in accordance with AASHTO Designation: T 67, ASTM Designation: E-4, at least once, and pressure gages shall be calibrated within one year preceding the time of use and whenever there is a reason to doubt the accuracy of the results. If the laboratory performing the calibration uses a hydraulic testing machine in lieu of the methods specified in AASHTO Designation: T 67 to apply the test load, the testing machine used to apply this load shall be calibrated in accordance with ASTM Method E 74, and the report shall state that the testing machine had been calibrated by this method. Calibration shall include loading and unloading with the jacking system to determine the hysteresis losses in the system. The calibration and certificate shall be made by a qualified testing laboratory approved by State Aid, and the Engineer shall be furnished a report and certificate of each calibration.

Systems containing two or more jacking pistons shall be approved by the Engineer before use and shall be subject to periodic calibration as determined by the Engineer.

**S-803.03.1.9.4.2.5--Preparation for Loading.** The Contractor shall provide means for preventing eccentricity in the pile during loading, and shall be fully responsible for all loss or damage caused by loading an eccentric pile or one which becomes eccentric during loading.

The pile to be load tested shall be installed as indicated on the plans to the specified tip elevation, or as directed. After the pile is in place, all loading devices shall be assembled in their proper position. Before load is applied to the pile, the measuring frame shall be assembled and positioned with gages properly installed.

The head of the pile shall be normal to the longitudinal axis or shall be capped in such a manner as to produce a plane bearing surface normal to the longitudinal axis. When cut-off is necessary, the head of the pile shall be normal to the longitudinal axis or capped as above. A one-inch steel plate of the pile size or larger shall be set on top of the pile.

The jacking system shall include a reaction member of sufficient strength and support to withstand required loads. The reaction member shall be attached to anchor piles or shall be weighted by a loaded stationary box or platform resting on cribbing or other supports, or a combination of both. Anchor piles shall not be closer to the test pile than five times the greatest dimension of the largest pile driven; except for 18-inch or larger piles the State Aid Bridge Engineer may authorize in writing reaction piles at a closer interval, subject to the conditions included in the authorization. The Contractor shall provide reaction facilities capable of withstanding at least two and one-half times the design load. All reaction facilities shall be subject to the approval of the Engineer with respect to possible adverse influence upon the behavior of the test pile.

**S-803.03.1.9.4.2.6--Application of Loads.** Unless otherwise directed by the Engineer, a time period of at least seven days shall elapse from the time the test pile and anchor piles, if used, are installed before the loading test is performed. During the required time lapse period, no other driving operations shall be performed within a 30-foot radius of the test pile, or a new seven-day period shall begin at the ending of the last pile driven within the 30-foot radius.

During the entire period that the test load or any portion thereof is on the pile, no pile driving operations, operation of heavy equipment, or any other operations shall be carried on within a distance, as determined by the Engineer, from the load test which might affect the behavior of the loaded pile. In the event of such occurrence, or in the event of failure of the reaction facilities or other loading and measuring equipment, the load test may be considered as defective and unacceptable, and in the case of driven piles only an additional seven-day waiting period shall elapse before the loading test is resumed.

Failure to perform the load test on drilled and cast-in-place test piles in accordance with these specifications will result in an unacceptable load test. Additionally, the failed load test will invalidate the test pile for further use and no payment will be allowed for the test pile or the load test.

Loads shall be applied in increments of 25 percent of the design load until a test load of 2 1/2 times the design load has been maintained as provided herein, or until the Engineer suspends the loading because of obvious failure of the pile to carry the specified load. A guide for determining whether the pile has failed is as follows:

- (A) For lengths of driven and cast-in-place concrete piles and timber piles up to 50 feet, a total top settlement of 1.0 inch and for lengths in excess of 50 feet, a total top settlement of 1.5 inches. However, for cast-in-place piles, when skin friction is broken there may be some settlement due to compression of relatively loose or bulked soil under the point of the pile, therefore the test must not be suspended until this possibility has been fully considered. Any special effort by the Contractor in the drilling and casting the test pile to prevent possible settlement from such cause shall be duplicated to the satisfaction of the Engineer for all piles represented by the load test.
- (B) For steel piles and steel pile shells not filled with concrete up to 60 feet in length, a total top settlement of 1.5 inches and for lengths in excess of 60 feet, a total top settlement of 2.0 inches.

Each of the following loading conditions shall be applicable until the loading is completed or unless the Engineer has suspended the loading because of obvious failure of the pile:

- a. Each loading increment, including the final increment, shall be maintained for a 15-minute period and for as many additional 15-minute periods, not to exceed two hours total time, as necessary to satisfy the conditions stated herein.
- b. During the entire loading, readings are to be made at each five-minute increment of each 15-minute period and are to be made to the nearest 0.001 inch.
- c. When the settlement rate for the pile in the last five-minute increment of a 15-minute period, averages less than 0.001 inch per minute, the next increment of load shall be applied.
- d. When at the end of a 15-minute period, the settlement rate in the last five-minute increment averages more than 0.001 inch per minute, the load increment shall remain applied for the necessary successive 15-minute periods up to a total of two hours, after which the next increment of load shall be applied.

- e. The total load shall be maintained on the pile for two hours unless directed otherwise directed by the Engineer.
- a. The pile shall be unloaded in accordance with S-803.03.1.9.4.2.7.

**S-803.03.1.9.4.2.7--Unloading and Measuring.** Unless the loading has been suspended by the Engineer, the pile shall be unloaded in decrements of 50 percent of the design load. Each decrement shall be maintained for a minimum of 15 minutes with settlement readings taken immediately before and after its removal and at five-minute intervals. The final settlement reading shall be taken two hours after the removal of the last decrement of load and shall mark the conclusion of the loading test.

**S-803.03.1.10--Pile Acceptance.** The safe allowable load for each type and size of pile will be as shown on the plans or as determined by the State Aid Bridge Engineer. Acceptance criteria for the length of permanent production piles will be based on the recommended lengths as determined by the State Aid Bridge Engineer from the test pile reports.

**S-803.03.1.11--Test Piles.** The Contractor shall furnish and install test piles of the sizes and types at the locations shown on the plans. It is the Contractor's responsibility to furnish test piles of sufficient length to obtain the minimum tip elevation and required bearing. This requirement may necessitate test pile lengths in excess of that required to reach minimum tip elevation. The number of test piles may be increased or decreased by the State Aid Bridge Engineer as field conditions warrant. If determined by the State Aid Bridge Engineer to be necessary, test piles shall be extended, built-up, or spliced and in the case of steel piles driven further. Similarly, the Contractor may be required to drive test piles below cut-off and extended as necessary.

### **S-803.03.2--Drilled Shafts.**

#### **S-803.03.2.1--Submittals.**

**S-803.03.2.1.1--Qualification of Contractor.** The person(s) or firm directing the work described in this specification shall be knowledgeable of drilled shaft installation procedures and shall have installed drilled shafts of both diameter and length similar to those shown in the plans in accordance with the following minimum experience requirements:

- (1) A drilled shaft Contractor shall have a minimum of three (3) years of drilled shaft installation experience prior to the bid date for this project; or,
- (2) A Contractor without prior drilled shaft experience shall employ a superintendent with a minimum of fifteen years of drilled shaft experience prior to the bid date of this project.

A Contractor with limited drilled shaft installation experience may use a combination of their experience and the superintendent's experience, with each five years of experience of the superintendent counting as equivalent to one year's experience of the Contractor. A signed statement listing the applicable work experience of the drilled shaft Contractor shall be submitted to the Engineer at the Preconstruction Conference, or no later than 45 calendar days prior to drilled shaft construction.

At the Preconstruction Conference, or no later than 45 calendar days prior to beginning drilled shaft construction, the Contractor shall furnish the Engineer evidence of the following:

- (1) A signed statement from the drilled shaft superintendent responsible for the drilled shaft installation that the project site has been visited, and that all the subsurface information has been inspected. This information includes the soil profiles and/or boring logs furnished in the plans, soil samples and rock cores, and the geotechnical investigation. All the above information may be obtained from the Engineer.
- (2) A signed statement from the drilled shaft Contractor detailing their ability to complete a project of this type. This shall be supported by a list containing a detailed description of at least three (3) projects completed in the last three (3) years on which the drilled shaft Contractor and/or superintendent has installed or supervised installation of drilled shafts similar in size to those shown in the plans, and utilized excavation methods similar to those anticipated for this project. This list of projects shall contain names and phone numbers of the project owner's representatives who can verify the drilled shaft Contractor's participation on the project, and the names of the superintendents who were in charge of the drilled shaft operations.
- (3) Name and experience records of the drilled shaft superintendent and driller who will perform the required work.

The Engineer will evaluate the evidence of qualifications submitted for conformance with these specifications. Should the information submitted be incomplete or not conform to the project specifications, the information will be rejected and the Contractor shall submit changes for reevaluation.

If the Contractor wishes to replace the drilled shaft superintendent or the driller during the life of the project, the name and experience record of their replacement shall be submitted to the Engineer for approval.

**S-803.03.2.1.2--Drilled Shaft Installation Plan.** At the Preconstruction Conference, or no later than 45 calendar days before drilled shaft construction begins, the Contractor shall submit to the Engineer an installation plan for review. This plan shall provide information on the following:

- (1) A copy of the proposed drilled shaft concrete mix design as submitted with the Contractor's Concrete Quality Control Plan. Construction of the trial shaft(s) will not commence until the drilled shaft concrete mix design has been approved in accordance with S-804.
- (2) List and size of proposed equipment including cranes, drill rigs, augers, bits, bailing buckets, digging buckets, final cleaning equipment, slurry tanks, desanding equipment, slurry pumps, tremies, pump lines, concrete pumps, casings, etc.
- (3) Details of the method of exploration including the equipment, if required.
- (4) Details of the sequence of construction operations and sequence of shaft construction within bents or shaft groups.
- (5) Details of shaft excavation method(s).
- (6) Details of slurry type and usage, including proposed methods to mix, circulate and desand slurry when slurry is required.
- (7) Details of proposed methods to clean the drilled shaft excavation upon reaching the minimum required tip elevation.
- (8) Details of reinforcement placement including the method of support while aligning the cage for placement into the drilled shaft excavation and the centering devices to be used to center the cage and assure minimum outside clear space shown in the plans.
- (9) Details of concrete placement including proposed operational procedures for concrete tremie or pump, including initial placement, raising during placement, and overfilling of the shaft concrete, and the ability of the concrete supplier to provide a continuous pour for the anticipated volumes.
- (10) Details of casing installation and removal, when required.
- (11) Details of any required load tests including equipment and recent calibrations for any jacks supplied by the Contractor.

The Engineer will evaluate the Contractor's Drilled Shaft Installation Plan for conformance with the plans and specifications, after which the Engineer will notify the Contractor within 14 calendar days of any additional information and/or changes that may be required. Any part of the plan that is unacceptable will be rejected and the Contractor shall submit changes for reevaluation.

All approvals given by the Engineer shall be subject to trial and satisfactory field performance, and shall not relieve the Contractor of the responsibility to satisfactorily complete the work as detailed on the plans and in the specifications.

**S-803.03.2.2--Trial Shaft Construction.** The Contractor shall demonstrate the adequacy of the methods and equipment during construction of an out of position trial shaft. This trial shaft shall be positioned as far as practical from the production shafts, in the position shown on the plans or as directed by the Engineer, and shall be drilled to the minimum tip elevation as required on the plans. When shown on the plans, the reaming of bells at specified trial shafts will be required to establish the feasibility of bellings in a specific soil strata. Failure to demonstrate the adequacy of the Contractor's methods and equipment to construct the trial shaft shall be cause for the Engineer to require alterations in equipment and/or method by the Contractor, to eliminate unsatisfactory results. Backfilling of unsuccessful excavations and any additional trial shafts required to demonstrate the adequacy of altered methods of construction or equipment shall be performed by the Contractor at no additional cost to the Project. Once the Contractor has completed the excavation for the trial shaft to the satisfaction of the Engineer, the Contractor shall set the reinforcement and pour the concrete to finish construction of the trial shaft. This shall be demonstration that the entire plan for drilled shaft construction is satisfactory. Failure to successfully construct the trial shaft shall be cause for rejection of the trial shaft, and shall be reason for the Engineer to require alterations necessary to eliminate unsatisfactory results. Additional trial shafts to demonstrate correction of deficiencies shall be at the Contractor's expense.

If differing soil conditions require two (2) or more methods for construction of production shafts, said methods shall be demonstrated by trial shaft prior to construction of any production shaft.

After the successful trial shaft has been completed, the Contractor shall submit in writing for review the successful methods and equipment used. This submittal, once reviewed, will serve as the approved method of construction for all the production shafts covered by that successful trial shaft. Once approval has been given to construct production shafts, no changes will be permitted in the methods, equipment, drilled shaft superintendent, or driller from those used during the construction of the trial shaft without written approval of the Engineer.

Trial shafts shall be cut off two (2) feet below finish grade or two (2) feet below the mudline and left in place. The portions of the shafts cut off and removed shall remain the property of the Contractor. The disturbed areas in the vicinity of the trial shaft shall be restored as nearly as practical to their original condition.

**S-803.03.2.3--Construction Methods and Equipment.****S-803.03.2.3.1--General.**

**S-803.03.2.3.1.1--Protection of Existing Structures.** When the plans require drilled shaft excavations within close proximity to existing structures or utilities, the Contractor shall take all reasonable precautions to prevent damage to such structures. This shall include newly constructed shafts. If not otherwise provided for in the plans, the Contractor shall be solely responsible for evaluating the need for, design of, and providing all reasonable precautionary features to prevent damage. These measures shall include, but are not limited to, selecting construction methods and procedures that will prevent caving of the shaft excavation, and monitoring and controlling the vibrations from construction activities, including the driving of casings, driving of sheeting, or from blasting, when permitted. Advancing an uncased drilled shaft excavation or the use of a vibratory hammer to install casings within 30 feet of a newly constructed shaft will not be permitted unless the concrete in that shaft has attained a compressive strength of 2500 p.s.i., as determined by cylinder tests. Based upon observations, the Engineer may adjust this distance accordingly. During shaft construction, the Contractor shall take into account and make provisions for vibrations caused by activities other than the Contractor's, such as adjacent traffic.

Such structures shall be monitored for settlement in an approved manner, recording elevations to 0.01 foot. The number and location of monitoring points shall be as approved by the Engineer. Elevations shall be taken before construction begins, during the driving of any required casings, and during excavation or blasting as directed by the Engineer.

When shown on the plans, or as directed by the Engineer, the Contractor shall monitor and record vibration levels during the driving of casings, sheeting, or during blasting operations. Vibration monitoring equipment shall be capable of detecting particle velocities of 0.1 inch/second or less.

At any time the Contractor detects settlement of 0.03 foot, vibration levels reaching 1.5 inches per second, or damage to the structure, the Contractor shall immediately stop the source of vibrations, backfill the excavation, and contact the Engineer for instructions.

**S-803.03.2.3.1.2--Construction Sequence for Site Preparation.** Excavation to the plan footing elevation, if required, shall be completed before shaft construction begins. Any disturbance to the footing area caused by shaft installation shall be repaired by the Contractor prior to the footing pour.

When drilled shafts are to be installed in conjunction with embankment placement, the Contractor shall construct the drilled shafts after placement of the embankment material.



**S-803.03.2.3.1.3--General Methods and Equipment.** The Contractor shall perform the excavations required for the shafts and bell footings, through whatever materials encountered to the dimensions and elevations shown on the plans, or otherwise required by the specifications, at no additional cost to the Project. The Contractor's methods and equipment shall be suited for the intended purpose and the materials encountered.

Drilled shafts shall be constructed by either the dry method, wet method, casing method, or permanent casing method, as necessary to produce a sound, durable, concrete foundation free of defects. The permanent casing method shall be used only when required by the plans or authorized by the Engineer. When the plans describe a particular method of construction, this method shall be used unless otherwise permitted by the Engineer. The Engineer may permit an alternate method than designated on the plans, only after successful construction of an out of position trial shaft. When the plans do not describe a particular method, the Contractor shall utilize a method on the basis of its suitability to the site conditions. Blasting shall only be permitted if specifically stated on the plans or approved by the Engineer.

Once approval is given to construct production shafts, no changes will be permitted in the methods or equipment from those used in constructing the accepted trial shaft without written approval of the Engineer.

**S-803.03.2.3.2--Dry Construction Method.** The dry construction method shall be used only at sites where the groundwater level and soil conditions are suitable to permit construction of the shaft in a relatively dry excavation, and where the sides and bottom of the shaft may be visually inspected by the Engineer prior to placing the concrete. The dry method consists of drilling the shaft excavation, placing the reinforcing cage, and concreting the shaft in a relatively dry excavation.

The dry construction method shall be used only when the trial shaft excavation demonstrates that: concrete can be placed with less than three (3) inches of accumulated water in the bottom of the shaft; the sides and bottom of the hole remain stable without caving, sloughing, or swelling over a two-hour period immediately following completion of the excavation; and any loose material and excess water can be satisfactorily removed prior to inspection and prior to concrete placement.

**S-803.03.2.3.3--Wet Construction Method.** The wet construction method shall be used at all sites where it is impractical to provide a dry excavation for placement of the shaft concrete.

The wet construction method consists of drilling the shaft excavation below the water table, keeping the shaft filled with water or mineral slurry, not a separate pay item, desanding or cleaning the slurry, final cleaning of the excavation by means of a bailing bucket, air lift, submersible pump or other approved devices, and placing the rebar cage and the shaft concrete, with a tremie or concrete pump beginning at the shaft bottom, which displaces the water or slurry as the shaft is concreted. Temporary surface casings shall be provided to aid shaft alignment and position and to prevent sloughing of the top of the shaft, except when the Contractor demonstrates to the satisfaction of the Engineer that the surface casing is not required.

Where drilled shafts are located in open water areas, the shafts shall be constructed by the wet method using casings extending from above the water elevation into the ground to protect the shaft concrete from water action during placement and curing of the concrete. The casing shall be installed in a manner that will produce a positive seal at the bottom of the casing so that there is no intrusion or extrusion of water or other materials into or from the shaft excavation. Casings for this application may include multiple casings, temporary casings, and/or designed permanent casings. The wet construction method may be used in combination with the dry method and temporary or permanent casing methods.

**S-803.03.2.3.4--Casing Construction Method.** The casing construction method may be used at sites when the dry or wet construction methods are inadequate to prevent hole caving or excessive deformation of the hole. In this method, the casing may be either placed in a predrilled hole if no caving, swelling, or yielding occurs, or advanced through the ground by twisting, driving, or vibration before being cleaned out.

When a formation is reached that is nearly impervious, a casing shall be placed in the hole and seated in the nearly impervious formation. Drilling may proceed as with the dry method to the projected depth. If seepage occurs at this point, temporary casing may be advanced further to create the dry condition. In the event seepage conditions prevent use of the dry method, excavation shall be completed using wet methods. The placement of the concrete shall proceed as with the wet or dry method, except that the casing shall be withdrawn after the concrete is placed.

When caving soils occur near the ground surface and/or if the top of the concrete for the drilled shaft is below the ground surface, the Contractor shall set a suitable temporary removable surface casing. The minimum surface casing length shall be the length required to prevent caving of the surface soils and to aid in maintaining shaft position and alignment. Predrilling with slurry and/or overreaming to the outside diameter of the casing may be acceptable if required to install the surface casing at some sites.

Where drilling is through materials having a tendency to cave, the drilling shall be advanced by drilling in a mineral slurry. In the event that a caving layer or layers are encountered that cannot be controlled by slurry, the Contractor shall install temporary removable casing through such caving layer or layers. Overreaming to the outside diameter of the casing may be required. However, the final dimensions of the drilled shaft shall not be altered to accommodate these construction practices unless approved by the Engineer. The Contractor shall take whatever steps are required to prevent caving during shaft excavation including installation of deeper casings. If the Contractor elects to remove a casing and replace it with a longer casing through caving soils, the Contractor shall adequately stabilize the excavation with slurry or backfill the excavation. Other approved methods which will control the size of the excavation and protect the integrity of the foundation soils may be used to excavate through caving layers.

**S-803.03.2.3.5--Permanent Casing Method.** The permanent casing method shall be used when required by the plans. In this method, a casing is driven to the prescribed depth before excavation begins. If full penetration cannot be attained, the Contractor may excavate material from inside the casing and the casing may be driven again until reaching the desired penetration. In some cases overreaming to the outside diameter of the casing may be required before driving the casing.

The casing shall be cut off at the prescribed elevation upon reaching the proper construction sequence, and the remainder of the casing is left in place.

**S-803.03.2.3.6--Excavation and Drilling Equipment.** The excavation and drilling equipment shall have adequate capacity including power, torque, and down thrust to excavate a hole of both the maximum diameter and to a depth 20 percent greater than the longest shaft shown on the plans.

The excavation and overreaming tools shall be of adequate design, size, and strength to perform the work shown on the plans or described herein. When the material encountered cannot be drilled using conventional earth augers with soil or rock teeth, drill buckets, and/or underreaming tools, the Contractor shall provide special drilling equipment including but not limited to: rock core barrels, rock tools, air tools, blasting materials, and other equipment as necessary to construct the shaft excavation to size and depth required. Approval of the Engineer is required before excavation by blasting is permitted.

Sidewall overreaming shall be required when the sidewall of the hole is determined by the Engineer to have either softened due to excavation methods or delays in excavation completion, swelled due to delays in concreting, or degraded because of slurry cake build-up. Overreaming thickness shall be a minimum of 1/2 inch and a maximum of three inches beyond the shaft radius. Overreaming may be accomplished with a grooving tool, overreaming bucket, or other approved equipment. The thickness and elevation of sidewall overreaming shall be as directed by the Engineer. The Contractor shall bear all costs associated with both sidewall overreaming and additional shaft concrete placement.

**S-803.03.2.3.7--Excavations.**

**S-803.03.2.3.7.1--General.** Shaft excavations shall be made at locations and to the top of shaft elevations, estimated bottom of shaft elevations, shaft geometry and dimensions shown in the plans. The Contractor shall extend drilled shaft tip elevations when the Engineer determines that the material encountered during excavation is unsuitable and/or differs from that anticipated in the design of the drilled shaft.

The Contractor shall maintain a drilling log during shaft excavation. The log shall contain information such as: the description and approximate top and bottom elevation of each soil or rock strata, seepage or groundwater, and remarks. Three (3) copies of the final Contractor's log shall be furnished to the Engineer at the time the drilled shaft is completed and accepted.

When shown on the plans, bells shall be excavated to form the height and bearing area of the size and shape shown. The bell shall be excavated by mechanical methods. Any drilled shaft concrete over the theoretical amount required to fill any excavations for the bells and shafts dimensioned on the plans shall be furnished at no additional cost to the Project.

The Contractor shall not permit workmen to enter a shaft excavation for any reason unless: both a suitable size casing has been installed and the water level has been lowered and stabilized below the level to be occupied, and adequate safety equipment and procedures have been provided to workmen entering the excavation. The Contractor is responsible for complying with all State and Federal safety regulations.

**S-803.03.2.3.7.2--Obstructions.** Surface and subsurface obstructions at drilled shaft locations shall be removed by the Contractor. Such obstructions may include man-made materials such as old concrete foundations, and natural materials such as boulders. Special procedures and/or tools shall be employed by the Contractor after the hole cannot be advanced using conventional augers fitted with soil or rock teeth, drilling buckets and/or underreaming tools. Such special procedures/tools may include but are not limited to: chisels, boulder breakers, core barrels, air tools, hand excavation, temporary casing, and increasing the hole diameter. Blasting shall not be permitted unless specifically approved in writing by the Engineer.

Drilling tools which are lost in the excavation shall be promptly removed by the Contractor at no cost to the Project. All costs due to lost tool removal shall be borne by the Contractor including, but not limited to, costs associated with hole degradation due to removal operations or the time the hole remains open.

**S-803.03.2.3.7.3--Exploration.** When directed by the Engineer, the Contractor shall take soil samples or rock cores to determine the character of the material directly below the completed shaft excavation. The soil samples shall be extracted with a standard penetration test split spoon sampler or undisturbed sample (Shelby) tube. Rock cores, if required, shall be cut with an approved double or triple tube core barrel to a minimum of five (5) feet below the bottom of the drilled shaft excavation at the time the shaft excavation is approximately complete. Rock core, undisturbed tube, and/or standard penetration test samples shall be measured, visually identified, and described on the Contractor's log. The samples shall be placed in suitable containers, identified by shaft location, elevation, and project number, and delivered with the Contractor's field log to the Engineer within 24 hours after the exploration is completed. The Engineer will inspect the samples, or cores, and determine the final depth of required excavation based on the evaluation of the material.

**S-803.03.2.3.7.4--Excavation Completion.** Concrete placement must begin within two (2) hours of completion of shaft excavation. If the drilled shafts are five (5) feet in diameter or larger and in excess of sixty (60) feet in length, the elapsed time from completion of the drilled shaft excavation until beginning concrete placement may extend past two hours provided the excavation remains stable and the extended time is demonstrated on the trial shaft. Completion of shaft excavation is defined as the time at which the specified tip elevation is initially achieved. Before concrete placement begins, bottom cleaning operations, any necessary slurry desanding, and placement of the reinforcing steel must be completed. These operations are included in the two hour time limit.

When it becomes apparent, as the excavation of the shaft is nearing completion, that it will not be feasible or possible to place concrete within the specified limit, the Contractor shall halt excavation operations a minimum of five (5) feet above the specified tip elevation. In the event that the wet construction method is being used, the slurry should be desanded at this point so that the remaining excavation will not cause the slurry to be too heavily contaminated and delay concrete placement due to final desanding operations.

In no case shall any excavation within the bearing zone(s) be allowed to remain open and idle for more than 24 hours. The bearing zone(s) are considered as those soil strata below the scour line, in the case of hydraulic structures, or those five feet below the ground line, whichever is greatest in depth. In no instance shall any uncased excavation, except for trial shafts, be allowed to remain open and idle for more than 24 hours. For partially completed excavations which stand idle for more than six (6) hours but less than 24 hours, sidewall overreaming may still be required by the Engineer.

If completion of shaft excavation has been achieved, and concrete placement has not begun within the specified limit, the Contractor shall backfill and/or stabilize the excavation. The Engineer shall then direct the Contractor as to the additional shaft excavation that will be required to produce a sound drilled shaft due to shaft wall and bottom degradation. The cost of the additional excavation, concrete, reinforcing steel, and other incidentals will be borne by the Contractor at no additional cost to the Project.

#### **S-803.03.2.3.7.5--Casings.**

**S-803.03.2.3.7.5.1--General.** Casings shall be steel, smooth, clean, watertight, and of ample strength to withstand both handling and driving stresses and the pressure of both concrete and the surrounding earth materials. The outside diameter of casing shall not be less than the specified size of shaft. No extra compensation will be allowed for concrete required to fill an oversized casing or oversized excavations. All casings, except permanent casing, shall be removed from the shaft excavation. Any length of permanent casing installed below the shaft cutoff elevations shall remain in place.

When the shaft is to extend above the ground or through a body of water, the portion exposed above the ground or through a body of water may be formed with removable casing, except when permanent casing is specified. Removable casing shall be stripped from the shaft in a manner that will not damage the concrete. Casings can be removed when the concrete is cured for a full 72 hours; the shaft concrete is not exposed to salt water or moving water for seven (7) days; and the concrete reaches a compressive strength of at least 2500 psi as determined from concrete cylinder tests.

**S-803.03.2.3.7.5.2--Temporary Casing.** All subsurface casing shall be considered temporary unless specifically shown as permanent in the contract documents. All temporary casing shall be removed. Telescoping, predrilling with slurry, and/or overreaming to beyond the outside diameter of the casing may be required to install the casing. When temporary casing larger than called for on the plans is used for telescoping or overreaming, no additional compensation will be made.

If the Contractor elects to remove a casing and substitute a longer or larger diameter casing through caving soils, the excavation shall be either stabilized with slurry or backfilled before the new casing is installed, as directed in S-803.03.2.3.4. Other methods, as approved by the Engineer, may be used to control the stability of the excavation and protect the integrity of the foundation soils.

When temporary casings which are to be removed become fouled or bound in the shaft excavation and cannot be practically removed, and concreting has not yet begun, the Engineer may direct that the shaft excavation be drilled deeper to compensate for the loss of capacity due to the presence of the casing. No additional compensation will be paid for the casing left in the excavation. No additional length of shaft will be paid for beyond the current depth of excavation or the plan tip elevation of the production shaft, whichever is lower.

Temporary casings which become bound or fouled during concreting of the shaft, and cannot be practically removed before the concrete begins to set up, shall constitute a defect in the drilled shaft. When the Engineer, in writing, notifies the Contractor of a defective shaft, the Contractor shall be responsible for improving such defective shafts to the satisfaction of the Engineer. Improvements may consist of, but are not limited to, removing the shaft concrete and extending the shaft deeper to compensate for loss of frictional capacity in the cased zone, providing straddle shafts to compensate for capacity loss, proof load testing or providing replacement shafts. All corrective measures, including redesign of footings or drilled shaft caps, shall be performed to the satisfaction of the Engineer by the Contractor without either additional compensation or extension of Contract Time. No compensation will be paid for casing remaining in place. Any redesigns submitted must be approved in writing by the State Aid Bridge Engineer.

Temporary casing extraction shall be slow and uniform, pulling along the axis of the shaft. The elevation of the concrete in the casing shall be maintained high enough to displace the drilling slurry between the outside of the casing and the edge of the hole as the casing is removed. Temporary casings shall be removed while the concrete remains workable. No temporary casings will be removed if the concrete slump is less than four (4) inches. Should this condition occur, the shaft will be designated as defective, and corrections to the situation shall be as described above.

Special casing systems may be used in open water areas, when approved, which are designed to permit removal after the concrete has hardened. Special casings shall be designed so that no damage occurs to the drilled shaft concrete during their removal. Any defects either cosmetic or structural that are apparent after removal of the casing or are due to the removal of the casing shall be repaired to the satisfaction of the Engineer at no additional cost to the Project.

In the event that permanent casing is not specified in the plans, and the Contractor elects to use a temporary casing and leave it in place, it shall be cut off at a maximum of 12 inches above the low water elevation as shown on the plans, or painted. Written approval from the Engineer is required in this event, and payment for the temporary casing left in place will be at the contract bid price for temporary casing.

**S-803.03.2.3.7.5.3--Permanent Casings.** Permanent casing shall be used when shown on the plans. The casing shall be continuous between top and bottom elevations prescribed on the plans or as directed by the Engineer. Exterior surfaces of permanent casing shall be painted in accordance with the plans unless otherwise noted. After installation is complete, the permanent casing shall be cut off at the prescribed elevation and the shaft completed.

In general, permanent casing shall not be placed in an overreamed shaft hole.

**S-803.03.2.3.8--Slurry.** Mineral slurries shall be employed when slurry is used in the drilling process, unless other drilling fluids are approved in writing by the Engineer. The slurry shall have both a mineral grain size that will remain in suspension and sufficient viscosity and gel characteristics to transport excavated material to a suitable screening system. The percentage and specific gravity of the material used to make the suspension shall be sufficient to maintain the stability of the excavation and to allow proper concrete placement. During construction, the level of the slurry shall be maintained at a height sufficient to prevent caving of the hole. In the event there is a sudden, significant loss of slurry within the drilled shaft excavation, the construction of the drilled shaft shall be stopped until a method to stop slurry loss or an alternate construction procedure has been approved by the Engineer.

Mineral slurry shall be premixed thoroughly with clean, fresh water, and an adequate time (as prescribed by the mineral manufacturer) shall be allotted for hydration, prior to introduction into the shaft excavation. Slurry tanks of adequate capacity will be required for slurry circulation, storage, and treatment. No excavated slurry pits will be allowed in lieu of slurry tanks, without the written permission of the Engineer. Desanding equipment shall be provided by the Contractor as necessary to control slurry sand content to less than two percent (2%) by volume at any point in the borehole. Desanding will not be required for setting sign post or lighting mast foundations unless shown on the plans. The Contractor shall take all steps necessary to prevent the slurry from "setting up" in the shaft. Such methods may include, but are not limited to: agitation, circulation, and/or adjusting the properties of the slurry. Disposal of all slurry shall be performed offsite in suitable areas by the Contractor, and subject to all environmental regulations pertaining to slurry disposal.

Control tests using suitable apparatus shall be carried out on the mineral slurry mixture by a qualified individual or qualified professional testing laboratory approved by the Engineer. Tests to be conducted will be density, sand content, viscosity, and pH. The acceptable range of values for those physical properties is as shown in the following table:



**MINERAL SLURRY**  
**Sodium Montmorillonite (Commercial Bentonite)**  
**Acceptable Range of Values**

Property Units	At Time of Slurry Introduction	In Hole at Time of Concreting	Test Method
Density, pcf	64.3** - 69.1**	64.3** - 75.0**	Density Balance
Viscosity, seconds/quart	28 - 45	28 - 45	Marsh Cone
pH	8 - 11	8 - 11	pH paper pH meter

\*\*Increase by 2 pcf in salt water

- Notes: a. Tests should be performed when the slurry temperature is above 40 degrees Fahrenheit.
- b. If desanding is required, sand content shall not exceed two percent (2%) by volume at any point in the borehole as determined by the American Petroleum Institute sand content test.

The limits in the above table may be adjusted when field conditions warrant, as successfully demonstrated on the trial shaft or as directed by the Engineer. All changes must be approved in writing by the Engineer before continued use.

Tests to determine density, viscosity, and pH value shall be performed during the shaft excavation to establish a consistent working pattern. A minimum of four (4) sets of tests shall be made during the first eight (8) hours of slurry use. When the results show consistent behavior, the testing frequency may be decreased to one set every four (4) hours of slurry use.

The Contractor shall insure that heavily contaminated slurry suspension, which could impair the free flow of concrete, has not accumulated in the bottom of the shaft. Prior to placing concrete in any shaft excavation, the Contractor shall take slurry samples using a sampling tool approved by the Engineer or similar to that shown in Figure 2. Slurry samples shall be extracted from the base of the shaft and at intervals not exceeding 10 feet up the shaft, until two consecutive samples produce acceptable values for density, viscosity, pH, and sand content.

When any slurry samples are found to be unacceptable, the Contractor shall take whatever action is necessary to bring the mineral slurry within specification requirements. Concrete shall not be poured until resampling and testing produce acceptable results.

Reports of all tests required above, signed by an authorized representative of the Contractor, shall be furnished to the Engineer on completion of each drilled shaft. The Engineer reserves the right to perform comparison tests as determined necessary during mineral slurry operations.

During construction, the level of mineral slurry in the shaft excavation shall be maintained at a level not less than four (4) feet above the highest expected piezometric pressure head along the depth of the shaft. If at any time the slurry construction method fails to produce the desired final results, the Contractor shall discontinue this method and propose an alternate method for approval by the Engineer.

Drilling tools should contain vents to stabilize hydrostatic pressure above and below the tool during extraction. The rate of tool extraction should not cause any noticeable turbulence in the hole.

In locations where saline or chemically contaminated groundwater exists, the slurry should be adjusted with appropriate chemical additives, or developed with a mineral material not affected by such conditions.

### SLURRY SAMPLER

The sampler consists of three components:

1. Cable with weighted cone-shaped stopper.
2. Cylindrical sampler center stayed for alignment.
3. Top stopper with hole drilled through the center.

#### SAMPLING PROCEDURE

1. Lower cable with stopper to desired sampling elevation.
2. Slide cable through aligning guides of sampler.
3. Let sampler drop down the cable & seat onto bottom cone-shaped stopper.
4. Slide cable through hole in top stopper and let drop to seat on top of sampler.
5. Withdraw entire assembly from shaft.
6. Sample may be emptied into separate container and used as necessary to perform required testing.

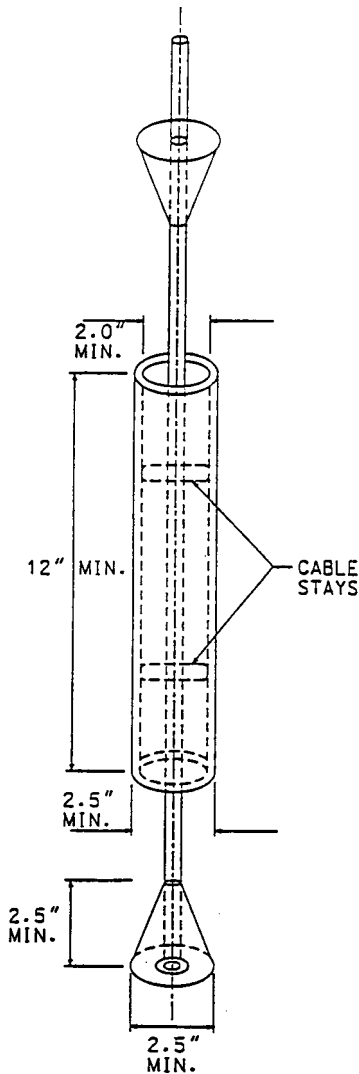

Figure 2

**S-803.03.2.4--Excavation Inspection.** The Contractor shall provide equipment for checking the dimensions and alignment of each drilled shaft excavation. The dimensions and alignment shall be determined by the Contractor in the presence of the Engineer or the Engineer's inspector. Final shaft depths shall be measured with a weighted tape or other approved methods after final cleaning. Unless otherwise stated on the plans, a minimum of 50 percent of the base of each shaft shall have less than 1/2 inch of sediment at the time of placement of the concrete. Shaft cleanliness will be determined by the Engineer, by visual inspection for dry shafts, or other methods deemed appropriate to the Engineer for wet shafts. In addition, for dry excavations, the maximum depth of water shall not exceed three (3) inches prior to concrete pour.

**S-803.03.2.5--Construction Tolerances.** The following construction tolerances apply to drilled shafts unless otherwise stated in the contract documents.

- (1) The drilled shaft shall be within three (3) inches of plan position in the horizontal plan at the plan elevation for the top of the shaft.
- (2) The vertical alignment of a vertical shaft excavation shall not vary from the plan alignment by more than 1/4 inch per foot of depth.
- (3) After all the concrete is placed, the top of the reinforcing steel cage shall be not more than three (3) inches below plan elevation.
- (4) All casing diameters shown on the plans refer to O.D. (outside diameter) dimensions. The dimensions of casings are subject to American Pipe Institute tolerances applicable to regular steel pipe. When approved, the Contractor may elect to provide a casing larger in diameter than shown on the plans.
- (5) Bells shall be excavated to the plan bearing area and height shown on the plans as a minimum. The actual diameter of the bells shall not exceed three (3) times the specified shaft diameter. All other plan dimensions shown for the bells may be varied, when approved, to accommodate the Contractor's equipment.
- (6) Top elevation of the shaft shall have a tolerance of plus one (1) inch or minus three (3) inches from the plan top of shaft elevation.
- (7) Excavation equipment and methods shall be designed so that the completed shaft excavation will have a planar bottom. The cutting edges of excavation equipment shall be normal to the vertical axis of the equipment within a tolerance of  $\pm 3/8$  inch per foot of shaft diameter.

Drilled shaft excavations and completed shafts not constructed within the required tolerances are unacceptable. The Contractor shall be responsible for correcting all unacceptable shaft excavations and completed shafts to the satisfaction of the Engineer. Materials and work necessary, including engineering analysis and redesign, to complete corrections for out of tolerance drilled shaft excavations shall be furnished without either cost to the Project or an extension of the completion dates of the project. Any redesign shall be performed by a professional engineer, registered in the State of Mississippi and engaged by the Contractor. Redesign drawings and computations prepared by the Contractor's engineer shall be signed and sealed.

Out of tolerance shaft holes shall be backfilled in an approved manner, when directed by the Engineer, until the redesign is complete and approved.

**S-803.03.2.6--Reinforcing Steel Construction and Placement**. The reinforcing steel cage, consisting of longitudinal bars, ties, cage stiffener bars, spacers, centralizers, and other necessary appurtenances, shall be completely assembled and placed as a unit immediately after the shaft excavation is inspected and accepted, and prior to concrete placement. Details of reinforcing steel will be as shown in the plans.

The reinforcing steel in the shaft shall be double-wire tied at all junctions and supported so that the reinforcing steel will remain within allowable tolerances given in S-803.03.1.5.1. Stiff tie wire may be required for long reinforcing steel cages. Free-rolling concrete centralizers or other approved noncorrosive rolling centralizer devices shall be used at sufficient intervals. The centralizers shall be attached to the reinforcing steel cage near the bottom, and at intervals not exceeding 10 feet up the shaft for shaft lengths less than 60 feet, and intervals not exceeding seven (7) feet for shaft lengths greater than 60 feet, to insure concentric spacing for the entire cage length. Centralizers shall be constructed of approved material equal in quality and durability to the concrete specified for the shaft. The centralizers shall be of adequate dimension to insure a minimum five (5) inch annular space between the outside of the reinforcing cage and the side of the excavated hole. Approved cylindrical feet (bottom supports) shall be provided to insure that the bottom of the cage is maintained the proper distance above the base.

The elevation of the top of the steel cage shall be checked before and after the concrete is placed. If the rebar cage is not maintained within the specified tolerances, corrections shall be made by the Contractor to the satisfaction of the Engineer. No additional shafts shall be constructed until the Contractor has modified the rebar cage support in a manner satisfactory to the Engineer.

If the bottom of the excavated shaft elevation is lower than the bottom of the shaft elevation shown on the plans, all reinforcement required in the upper portion of the shaft shall be achieved by splicing the additional length at the bottom of the cage, to avoid congestion in the upper portion of the shaft.

**S-803.03.2.7--Concrete Placement.**

**S-803.03.2.7.1--General.** Drilled Shaft concrete shall meet the requirements in S-804.

Concrete placement during cold weather shall be allowed when ambient air conditions are at or expected to drop below 40°F, but protection of the fresh concrete shall be in accordance with the provisions stated in S-804. The Contractor shall assume all responsibility for protection of fresh concrete in cold weather.

Concrete shall be placed as soon as possible after reinforcing steel placement. Concrete placement shall be continuous from the bottom to the top elevation of the shaft. Concrete placement shall continue after the shaft excavation is full until good quality concrete is evident at the top of the shaft. Concrete shall be placed either through a tremie, concrete pump or free fall. Free fall placement shall require prior written approval of the Engineer and shall be restricted for use in dry excavations only.

For tremied or pumped concrete, the elapsed time from the beginning of concrete placement in the shaft to the completion of the placement shall not exceed four (4) hours, except as noted below. Retarders and/or water reducers in the concrete mix shall be adjusted as approved for the conditions encountered on the job, so that the concrete remains in a workable plastic state throughout the four hour placement limit. This is defined as a minimum slump of four (4) inches existing everywhere within the concrete shaft after placement has been completed. Prior to concrete placement, the Contractor shall provide test results of a trial mix, set time test per AASHTO Designation: T 197, and a slump loss test using approved methods, to demonstrate that the concrete meets this four hour requirement. These tests shall be conducted by an approved testing laboratory at least 30 days prior to initial concrete placement, with the MDOT's Central Laboratory personnel or other approved Laboratory personnel present, at temperatures and conditions similar to those at the job site at the time of the shaft pour. However, the Contractor may request a longer placement time, provided a concrete mix is supplied that will maintain a slump of four (4) inches or greater over the longer placement time, as demonstrated by trial mix, set time, and slump loss tests. A slump loss test shall be conducted from the concrete at the site for verification of slump loss requirements, using a sample from a minimum batch size of four cubic yards of concrete.

In the event that free-fall concrete placement is approved and used, the four inch slump in four hours requirement will be waived. However, a different trial mix must be approved with its corresponding set time and slump loss tests.

The Contractor shall place the concrete within the approved time and temperature limitations determined by the trial mix demonstration.

Before the casing is withdrawn, the level of fresh concrete shall be at such a level that the fluid trapped behind the casing is displaced upward. As the casing is withdrawn, care shall be exercised to maintain the level of concrete within the casing so that the fluid trapped behind the casing is displaced upward out of the shaft excavation without mixing with or displacing the shaft concrete.

**S-803.03.2.7.2--Tremies.** Tremies used for concrete placement in either wet or dry excavations shall consist of a tube of sufficient length, weight, and diameter to discharge concrete at the shaft base elevation. The tremie shall not contain aluminum parts which will have contact with the concrete. The tremie inside diameter shall be at least six (6) times the maximum size of aggregate used in the concrete mix but shall not be less than 10 inches. The inside and outside surfaces of the tremie shall be clean and smooth to permit both flow of concrete and unimpeded withdrawal during concreting. The wall thickness of the tremie shall be adequate to prevent crimping or sharp bends which restrict concrete placement.

The tremie used for wet excavation concrete placement shall be watertight. Underwater placement shall not begin until the tremie is placed at the bottom of the excavation. Valves, bottom plates, or plugs may be used only if concrete discharge can begin within one tremie diameter of the base. Plugs and plates shall either be removed from the excavation or be of a material, approved by the Engineer, which will not cause a defect in the shaft if not removed. The discharge end of the tremie shall be constructed to permit the free radial flow of concrete during placement operations. The tremie discharge end shall remain at the excavation bottom as long as possible, and thereafter be immersed at least two shaft diameters but not less than 10 feet in concrete at all times after starting the flow of concrete. The flow of concrete shall be continuous. The concrete in the tremie shall be maintained at a positive pressure differential at all times to prevent water or slurry intrusion into the shaft concrete.

If, at any time during the concrete pour in a wet excavation, the tremie line orifice is removed from the fluid concrete column and discharges concrete above the rising concrete level, the shaft shall be considered defective. In such case, the Contractor shall remove the reinforcing cage and concrete, complete all necessary sidewall removal directed by the Engineer and repour the shaft. All costs of replacement of defective shafts shall be the responsibility of the Contractor.

**S-803.03.2.7.3--Pumping Concrete.** Concrete pumps and lines may be used for concrete placement in either wet or dry excavations. All pump lines shall have a minimum five (5) inch diameter and be constructed with watertight joints. The use of aluminum pipe as a conveyance for the concrete will not be permitted. Concrete placement shall not begin until the pump line discharge orifice is at the bottom of the excavation.

For wet excavations, a plug or similar device shall be used to separate the concrete from the fluid in the hole until pumping begins. The plug shall either be removed from the excavation or be of a material, approved by the Engineer, which will not cause a defect in the shaft if not removed.

The discharge orifice shall remain at least two shaft diameters but not less than 10 feet below the surface of the fluid concrete at all times after starting the flow of concrete. When lifting the pump line during concreting, the Contractor shall temporarily reduce the line pressure until the orifice has been repositioned at a higher level in the excavation.

If, at any time during the concrete pour, the pump line orifice is removed from the fluid concrete column and discharges concrete above the rising level, the shaft shall be considered defective. In such case, the Contractor shall remove the reinforcing cage and concrete, complete all necessary sidewall removal directed by the Engineer and repour the shaft. All costs of replacement of defective shafts shall be the responsibility of the Contractor.

**S-803.03.2.7.4--Free Fall Method.** Placement of concrete by the free fall method will be permitted only when approved in writing by the Engineer. Approval of concrete placement by the free fall method shall be contingent upon the following conditions:

- (1) The clear opening inside the reinforcing cage is not less than 24 inches in diameter.
- (2) The dry construction method is used in constructing the drilled shafts.
- (3) The height of free fall placement shall not exceed 75 feet.
- (4) Concrete shall fall directly to the placement location without contacting either the reinforcing cage or shaft walls.
- (5) A hopper shall be used at the top of the shaft to center and direct free fall placement.
- (6) The Engineer will observe the falling of the concrete within the shaft. The Contractor shall reduce the rate of concrete placement or reduce the height of free fall as directed by the Engineer when the concrete strikes the reinforcing cage or shaft sidewalls, when there is excessive spatter from the impact of the falling concrete, or when concrete placement causes the shaft excavation to cave or slough.
- (7) When in the opinion of the Engineer, placement cannot be satisfactorily accomplished by the free fall method, the Contractor shall change to either the tremie or pumping method to accomplish the pour.



**S-803.03.2.8--Drilled Shaft Load Tests.** The methods required for the load testing of drilled shafts shall be Static and/or Static with Special Instrumentation. Load testing of drilled shafts shall be completed before construction of any production drilled shafts, and the results used by the Engineer to determine the drilled shaft lengths given on the order list. The method, number, and locations of load tests shall be as shown on the plans or as designated by the Engineer.

After completion of any load test, the order list providing the final production lengths will be provided within two weeks of receiving the load test results. The production shaft lengths provided by the Engineer may differ from the individual shaft lengths shown on the plans. Requests for adjustment to the contract due to changes in shaft lengths shall be subject to the provisions of S-104.02.1. Before any consideration will be given for an adjustment to the contract, it must be determined that a significant change in the character of the work has occurred.

**S-803.03.2.8.1--Static Load Tests.** Static load testing shall not begin until the concrete has attained a compressive strength of 3000 psi as determined from cylinder tests. During the curing time, no other construction or operations which will induce excessive vibration levels, as previously discussed, shall be performed.

Static axial load tests shall be performed by personnel of the Geotechnical Branch of MDOT or other approved Lab assisted by the Contractor's personnel using the procedures as described in ASTM Designation: D 1143, quick test method. No weighted platforms to totally supply the axial load are allowed.

The Contractor shall be responsible for furnishing the following:

- (1) A reaction frame capable of resisting a total load of at least four (4) times the design load of the test shaft shall be provided. The frame shall consist of a beam(s) or girder(s) that will carry the required load while sustaining only minor deflections in the reaction system. The beam or girder shall be attached to a system of anchor shafts or piles. The anchor piles shall not be closer than three (3) diameters measured from the center of the test shaft.
- (2) A hydraulic jack that has been calibrated for the full range of anticipated loads in accordance with AASHTO Designation: T 67 (ASTM Designation: E 4) at least once. The maximum anticipated load shall be assumed to be four (4) times the design load for the test shaft. The pressure gage shall be calibrated within one year preceding time of use. The Contractor shall furnish a certificate of calibration for the hydraulic jack at the time of load testing.

- (3) A measuring frame or reference beam for measuring the movement of the test shaft during testing. Two dial gages, supplied by the Contractor, will be attached to the test shaft during testing to monitor downward movement. Each dial gage will be actuated by its stem or by a stem attachment resting on the measuring frame. The supports for the measuring frame shall be placed the maximum practical distance from the test pile and the anchor shafts or piles. In no case shall the measuring frame be affected by movement of the test shaft or the anchor shafts or piles.

The Contractor will furnish the load cell, gages, any needed details of the shaft gage locations and personnel to run the test. The MDOT Geotechnical Branch or other approved Lab shall be responsible for reviewing and submitting the results to the Engineer. The Contractor shall submit a detailed plan for any jacks and load frame to the Engineer for evaluation. This plan should include the following:

- (1) Size and type of the reaction beam or beams.
- (2) Size, type, number, and length of reaction piles or shafts.
- (3) Type and capacity of any jacks and their most recent calibration documents.
- (4) A plan sheet shop drawing showing plan and profile of load frame details. Details should be shown for of how the reaction beam will be connected to the reaction piles or shafts. A detail showing how the jack, load cell (6" height, 11" diameter, supplied by the Contractor), and bearing plates are to be arranged between the shaft top and the bottom of the reaction beam.
- (5) Details of a protected work area, including provisions such as a tent or shed for protection from inclement weather for the testing equipment, of a size and type required by the Engineer.

After testing is completed, the test shafts and any anchor shafts shall be cut off at an elevation two (2) feet below the finished ground surface. The portion of the shafts cut off and removed shall remain the property of the Contractor.

**S-803.03.2.8.2--Load Testing of Drilled Shafts With Special Instrumentation.**

**S-803.03.2.8.2.1--General.** When designated on the plans, a dedicated test shaft shall be constructed as detailed in the plans with instrumentation and hydraulic jack(s) cast in the concrete of the drilled shaft. The Contractor will be required to furnish all materials, equipment, labor, and incidentals necessary for conducting the load test and reporting the results. The Contractor shall subcontract the instrumenting, conducting, and reporting of the load test to the company supplying the instrumentation with the cost included in prices bid for test shaft.

No reaction systems and extra drilled shaft installations such as anchor shafts are required for conducting the load test. The load test is a non-destructive test, and if the test shaft designated on the plans is a production shaft, it shall be left in a condition suitable for use as a production shaft in the finished structure.

**S-803.03.2.8.2.2--Materials.** When called for in the plans, instrumentation shall be supplied to meet the requirements set forth in the plans. Instrumentation required in the plans are subject to prior approval by the Engineer. Additional equipment that may be required is as follows.

- (1) Materials sufficient to construct a stable reference beam system for monitoring deflection of the shaft during testing, supported at a minimum distance of three (3) diameters from the center of the shaft to prevent disturbance of the reference system.
- (2) Materials sufficient to construct a protected work area, including provisions such as a tent or shed for protection from inclement weather for the load test equipment, of size and type required by the Engineer.

Materials supplied which do not become a part of a finished structure shall be removed from the job site at the conclusion of the load test.

**S-803.03.2.8.2.3--Equipment.** The Contractor shall supply any additional equipment required to install the testing instrumentation and conduct the load test, remove the load test apparatus, and, if the test shaft is to become a production shaft at the conclusion of the test, restore the shaft to a condition suitable for use in the finished structure. This equipment includes, but is not limited to:

- (1) Electric power and welding equipment, as required, to assemble the test equipment, instrumentation, and prepare the work area.
- (2) A suitable pressurized gas source consisting either of an approved air compressor or of compressed nitrogen, i.e. four 230 cubic-foot cylinders of nitrogen per load test.

- (3) Equipment and operators for handling the instrumentation and reinforcing cage, if required, during the installation of the test shaft and during the test. This shall include, but is not limited to, a crane or other lifting device, manual labor, and hand tools.
- (4) Equipment and labor sufficient to erect the protected work area and monitoring reference beam system, to be constructed to the requirements of the Engineer and instrumentation supplier.
- (5) Approved small piston type power grout pump with experienced operator, for grouting the cell upon completion of the test if required. Successful demonstration that the grout pumping system works as intended will be required before placing the instrumentation in the test shaft hole.
- (6) Approved small power mortar mixer with suitable mortar box to discharge grout, if required, with an experienced operator.
- (7) Screen with an approximately 1/4-inch mesh to screen grout prior to placement in the grout pump to prevent clogging of the grout pump or the piping.
- (8) Suitable operating and reference level platforms, as required by the Engineer and/or instrumentation supplier, for testing over water or in otherwise unstable foundation conditions.

**S-803.03.2.8.2.4--Procedure.** The test shaft shall be constructed by the shaft construction technique approved by the Engineer after trial shaft construction. The test shaft shall then be constructed in accordance with the plans and at the direction of the Engineer.

The instrumentation shall be assembled and made ready for installation under the direction of the instrumentation supplier, in a suitable area, adjacent to the test shaft, to be provided by the Contractor. When a reinforcing cage is required for the test shaft, the instrumentation shall be placed as directed in the plans.

When the test shaft excavation has been completed and accepted by the Engineer, the Contractor shall then install the instrumentation and, if required, the reinforcing cage assembly in the test shaft under the direction of the Engineer. The Contractor shall use the utmost care in handling the reinforcing cage and test equipment assembly so as not to damage the instrumentation during installation.

After the installation of the instrumentation, the test shaft shall be concreted in the manner approved from the trial shaft construction. Load testing shall not begin until the concrete has attained a compressive strength of 3000 psi as determined from cylinder tests. During the curing period, no other construction or operations which will induce excessive vibration levels shall be performed.

After completion of the load test, and at the direction of the Engineer, the Contractor shall remove any equipment, material, etc. which are not to be a part of the finished structure.

The Contractor shall supply the Engineer with six (6) copies of the final load test report.

**S-803.04--Method of Measurement.**

**S-803.04.1--Test Piles.** Test piles will be measured per each complete-in-place. Piles measured as test piles will not be included in the measurement of pay footage for permanent piles.

Test piles constructed in accordance with the lengths indicated on the plans and which are required to be extended or built up will be measured as a percentage, calculated by dividing the sum of the plan length plus the length of the ordered extension or build-up, by the plan length. Splices required for the extension(s) will not be measured for payment. No measurement for payment will be made for cut-off of a test pile.

**S-803.04.2--Conventional Static Pile Load Tests.** Conventional static pile load tests will be measured by the actual number of static load tests conducted on either a test pile or permanent production pile in accordance with these specifications.

In the event a pile is reloaded in accordance with these specifications, the reloading will be measured for payment as 50 percent of a separate conventional static pile load test.

**S-803.04.3--Pile Shoes.** Pile shoes of approved design, ordered and used, will be measured and paid as set out in S-803.05.3.

**S-803.04.4--Piling.** Piling, exclusive of those measured as test piles, will be measured by the linear foot for each class and size of piling furnished and installed in accordance with lengths shown on the plans or approved by the State Aid Bridge Engineer. Cut-offs for each individual pile will be measured and deducted as set forth in S-803.04.5.

Pile lengths in excess of those shown on the plans or approved by the State Aid Bridge Engineer will not be measured for payment unless such additional lengths below cut-off are approved in writing by the State Aid Bridge Engineer for incorporation in the structure.

**S-803.04.5--Cut-Off.** The summation of all cut-offs shall be deducted at 50 percent to determine the length for payment of in-place permanent piling.

The summation of all cut-offs for pile lengths in excess of those shown on the plans or approved by the State Aid Bridge Engineer will be deducted at 100 percent to determine the length for payment of in-place permanent piling.

An allowance will be made for prestressed concrete piling cut-offs in accordance with the provisions of S-803.05.5. Cut-offs shall be measured for payment per each for each pile requiring cut-off. All piling cut-offs shall become the property of and shall be disposed of by the Contractor.

**S-803.04.6--Extensions or Build-Ups.** Extensions or build-ups will not be measured for payment as such, but will be included in the length of piling remaining in the finished structure. In determining the amount to be included in piling footage, no allowance will be made for cut-offs necessary to accomplish the extensions or build-ups.

**S-803.04.7--Falsework and Defective Piles.** No allowance will be made for furnishing or driving of falsework piles, for piles driven out of place, for defective piles, or for piles which are damaged by handling or driving.

**S-803.04.8--Splices.** Splices necessary for extensions or build-ups on bearing piles will be measured by the linear foot. For prestressed concrete piles, the number of linear feet will be determined by allowing seven linear feet of piling for each splice. For other piles, the number of linear feet will be determined by allowing four linear feet of piling for each splice. The total number of linear feet of piling to be paid for shall be determined by adding seven feet or four feet, as applicable, to the net length of piling for each splice in place in the finished structure.

No measurement or payment will be made for splices except those made at the direction and under the supervision of the Engineer.

**S-803.04.9--Pre-formed Pile Holes.** Pre-formed pile holes, when included as a pay item on the plans, will be measured by the linear foot. For trestle type bents, the footage for each hole will be determined by subtracting the elevation of the bottom of the hole shown on the itemized list from the elevation of the natural ground at the pile site or from the elevation of the excavated section, whichever is lower. For foundations and end bents, the footage will be determined by subtracting the elevation of the bottom of the hole as shown on the itemized list from the elevation of the bottom of the footing or the bottom of the end bent caps, as applicable.

**S-803.04.10 thru S-803.04.12--Blank.**

**S-803.04.13--Pile Restrike.** The pile restrike will be conducted as directed by the Engineer for bearing determination on permanent or test piles and no additional compensation will be allowed.

**S-803.04.14--Drilled Shaft.** Drill shaft will be measured per linear foot. Measurement shall be the authorized length in feet of the completed concrete drilled shaft, including bells, of the diameter and containing the reinforcement shown on the plans. The length shall be determined as the difference between the plan top of shaft elevation and the final bottom of shaft elevation.

**S-803.04.15--Test Shaft.** Test shaft of the specified diameter will be measured per each. Such measurement shall be full compensation for excavating the test shaft through whatever materials are encountered to the bottom of the shaft elevation shown on the plans or as authorized by the Engineer, concrete, reinforcement, required casings, special instrumentation load cell when required, conducting and reporting load test results, restoring the site as required, and all other expenses to complete the work.

**S-803.04.16--Trial Shaft.** Trial shaft of the specified diameter will be measured per linear foot. Such measurement shall be full compensation for excavating the trial shaft hole through whatever materials are encountered to the bottom of shaft elevation shown on the plans or as authorized by the Engineer, using mineral slurry as necessary, utilizing temporary casing as necessary which is not a separate pay item, providing inspection facilities, backfilling the holes, setting reinforcement and placing concrete as required, restoring the site, and all other expenses necessary to complete the work.

**S-803.04.17--Exploration.** Exploration will be measured per linear foot of soil samples and/or rock cores of the diameter and length required and authorized by the Engineer. Such measurement shall be full compensation for drilling, extracting, packaging and classifying the samples or cores, delivering them to the MDOT Lab or other approved Lab, furnishing concrete to fill the core hole, and all other expenses necessary to complete the work.

**S-803.04.18--Casing.** Casing shall be measured per linear foot. Such measurement shall be full compensation for furnishing, placing, and removing when required, the casing in the shaft excavation.

**S-803.05--Basis of Payment.**

**S-803.05.1--Test Piles.** Test piles, measured as prescribed above, will be paid for at the contract unit price per each.

**S-803.05.2--Conventional Static Pile Load Tests.** Conventional static pile load tests, measured as prescribed above, will be paid for at the contract unit price per each.

**S-803.05.3--Pile Shoes.** If not covered by a contract item or otherwise required by the plans, metal shoes ordered by the Engineer will be paid for at double the invoice cost of the shoe. The cost of placing the pile shoes and driving piling with these additional requirements will not be paid for directly, and the cost thereof shall be considered incidental to the respective pile driving pay item.

**S-803.05.4--Piling.** Piling of the type specified will be paid for at the contract unit price per linear foot.

**S-803.05.5--Cut-Offs.** For permanent prestressed concrete piles required to be cut off and the cut-offs are not necessitated by damage to the pile or as a result of a pile furnished in a length greater than that established by the pile list on the plans or furnished by the State Aid Bridge Engineer, the Contractor will be paid \$60.00 per each pile cut-off for sizes smaller than 20 inches and \$80.00 per each pile cut-off for sizes 20 inches and larger.

**S-803.05.6--Extensions or Build-Ups.** Extensions or Build-ups will not be paid for directly, but will be included in payment for piling. No payment will be made for extensions or build-ups for test piles.

**S-803.05.7--Blank.**

**S-803.05.8--Splices.** Splices, measured as per S-803.04.8, will be paid for at the contract unit price per linear foot for the particular type pile splices.

**S-803.05.9--Pre-formed Pile Holes.** Pre-formed pile holes of the sizes specified will be paid for at the contract unit price per linear foot.

**S-803.05.10 thru S-803.05.12-- Blank.**

**S-803.05.13--Pile Restrike.** Pile restrikes, will not be paid for.

**S-803.05.14--Drilled Shafts.** Drilled shafts of the type specified, measured as prescribed above, will be paid for at the contract unit price per linear foot, which price shall include the cost of concrete, reinforcing steel, and all labor, materials including mineral slurry, equipment, and incidentals necessary to complete the drilled shaft.

**S-803.05.15--Test Shafts.** Test shafts of the type specified, measured as prescribed above, will be paid for at the contract unit price per each, which price shall be full compensation for excavating the test shaft through whatever materials are encountered to the bottom of the shaft elevation shown on the plans or as authorized by the Engineer, concrete, reinforcement, required casings, special instrumentation load cell if required, conducting and reporting load test results, restoring the site as required, and all other expenses to complete the work.



**S-803.05.16--Trial Shaft.** Trial shafts of the type specified, measured as prescribed above, will be paid for at the contract unit price per linear foot, which price shall be full compensation for excavating the trial shaft through whatever materials are encountered to the bottom of the shaft elevation shown on the plans or as authorized by the Engineer, concrete, reinforcement, required casings, special instrumentation if required, conducting and reporting load test results, restoring the site as required, and all other expenses to complete the work.

**S-803.05.17--Exploration.** Exploration, measured as per S-803.04.17, will be paid for at the contract unit price per linear foot, which price shall be full compensation for drilling, extracting, packaging and classifying the samples or cores, delivering them to the MDOT Lab or other approved Lab, furnishing concrete to fill the core hole, and all other expenses necessary to complete the work.

**S-803.05.18--Casings.** Casings, measured as per S-803.04.18, will be paid for at the contract price per linear foot, which price shall be full compensation for furnishing, placing, and removing (when required) the casing in the shaft excavation.

**COMPENSATION**

The prices thus paid shall be full compensation for all materials, tools, equipment, labor, and incidentals required to complete work.

Payment will be made under:

<b><u>S-803-A:</u></b> Test Pile	- per each
<b><u>S-803-B:</u></b> Conventional Static Pile Load Test	- per each
<b><u>S-803-C:</u></b> ___” Prestressed Concrete Piling	- per linear foot
<b><u>S-803-D:</u></b> ___” Cast-in-Place Concrete Piling (Steel Shell)	- per linear foot
<b><u>S-803-E:</u></b> ___” Steel Piling	- per linear foot
<b><u>S-803-F:</u></b> ___” Pre-formed Pile Hole	- per linear foot
<b><u>S-803-G:</u></b> Blank	
<b><u>S-803-H:</u></b> Blank	
<b><u>S-803-I:</u></b> Blank	
<b><u>S-803-J:</u></b> Blank	
<b><u>S-803-K:</u></b> Drilled Shaft, ___” Diameter	- per linear foot
<b><u>S-803-L:</u></b> Test Shaft, ___” Diameter	- per each
<b><u>S-803-M:</u></b> Trial Shaft, ___” Diameter	- per linear foot
<b><u>S-803-N:</u></b> Exploration	- per linear foot
<b><u>S-803-O:</u></b> ___* Casing, ___” Diameter	- per linear foot

\* Temporary or Permanent

**SECTION S-804 - CONCRETE BRIDGES AND STRUCTURES**

**S-804.01--Description.** This work shall consist of constructing concrete bridges and structures in accordance with these specifications and in reasonably close conformity with the dimensions, designs, lines, and elevations indicated on the plans or established.

Construction of box bridges shall be in accordance with S-601 and S-602.

**S-804.02--Material.**

**S-804.02.1--General.** Concrete produced and controlled from this specification shall be accepted upon proper certification of concrete production through an approved quality control program and verification by job site acceptance criteria. The Contractor shall develop and implement a quality control program that will be used to maintain the required properties of concrete. Quality control and acceptance shall be achieved by individual test results. For projects less than or equal to 20 cubic yards, refer to the requirements of State Aid’s SOP SA-II-3-7.

The materials for concrete bridges and structures, when sampled and tested in accordance with S-700.03, shall meet the requirements of the following Subsections:

Portland Cement .....	S-701.01 and S-701.02
Admixtures .....	S-713.02
Fly Ash .....	S-714.05
Water .....	S-714.01.1 and S-714.01.2
Fine Aggregate .....	S-703.02
Coarse Aggregate .....	S-703.03
Curing Materials .....	S-713.01
Joint Materials .....	S-707.01, S-707.02, and S-707.07
Structural Steel Joints and Bearing Devices .....	S-717.01
Sheet Copper .....	S-716.07.2
Bronze Bearing Devices .....	S-716.06
Copper-Alloy Bearing Devices .....	S-716.07.1
Self-Lubricating Bearing Plates .....	S-716.08
Bearing Pads .....	S-714.10
Wire Rope or Wire Cable for Prestressed Concrete .....	S-700.01 and S-711.03
Sprayed Finish for Concrete Surface .....	S-714.12
Reinforcing Steel .....	S-711.02

**S-804.02.2--Use, Care and Handling.** The use, care and handling of materials shall conform to the specific requirements of S-804.02.4 and S-804.02.5. Unless otherwise authorized, only fine aggregate or coarse aggregate of one type and from the same source shall be used in the construction of any one unit of a structure. Should the Contractor, with written permission of the Engineer, elect to substitute high early strength cement for cement of the type specified, the Contractor will not receive additional compensation for the substitution.

**S-804.02.3--Sampling & Testing.** Sampling and testing shall meet the requirements of these specifications.

**S-804.02.4--Care and Storage of Concrete Aggregates.** The handling and storage of aggregates shall be such as to prevent segregation or contamination with foreign materials. The Engineer may require that aggregates be stored on separate platforms at satisfactory locations.

When specified, coarse aggregates shall be separated into two or more sizes in order to secure greater uniformity of the concrete mixture. Different sizes of aggregate shall be stored in separate stock piles sufficiently removed from each other to prevent the material at the edges of the piles from becoming intermixed.

**S-804.02.5--Storage of Cement.** All cement shall be stored in suitable weather-proof buildings or bins. These buildings or bins shall be placed in locations approved by the Engineer. Provision for storage shall be ample, and the shipments of cement as received shall be stored separately or other provisions made to the satisfaction of the Engineer for easy access for the identification, inspection, and sampling of each shipment as deemed desirable. Stored cement shall meet the test requirements at any time after storage when a retest is ordered by the Engineer.

On small jobs, open storage consisting of a raised platform and ample waterproof covering may be permitted by written authorization from the Engineer.

When specified, the Contractor shall keep accurate records of deliveries of cement and of its use in the work. Copies of these records shall be supplied in the form required by the Engineer.

**S-804.02.6--Classification and Uses of Concrete.** When a specific class of concrete is not specified on the plans or in the contract documents, the structure or parts thereof shall be constructed with the class of concrete as directed by the Engineer.

The classes and their uses are as follows:

- (1) Class AA - Concrete for bridge construction and concrete exposed to seawater.
- (2) Class A - Concrete for use where indicated.
- (3) Class B - General use, heavily reinforced sections, cast-in-place concrete piles, and conventional concrete piles.
- (4) Class BB - Box Bridge Concrete
- (5) Class C - Massive sections or lightly reinforced sections.
- (6) Class D - Massive unreinforced sections and riprap.
- (7) Class DS - Drilled Shaft Concrete
- (8) Class F - Concrete for prestressed members.
- (9) Class FX - Extra strength concrete for prestressed members, as shown on plans.
- (10) Class S - For all seal concrete deposited under water.

**S-804.02.7--Composition of Concrete.** The composition of concrete mixtures shall meet the requirements of these specifications.

**S-804.02.8--Laboratory Accreditation.** The Contractor shall be responsible for furnishing the laboratory used to perform concrete quality control tests. The laboratory may be the Contractor's facility, the concrete producer's facility, or a certified independent testing laboratory.

Only laboratories certified by the Mississippi Department of Transportation are qualified to perform material testing. Certification by AASHTO Accreditation Program (AAP) will be acceptable if the laboratory is listed in the latest AASHTO Accreditation Program publication and maintains accreditation to completion of concrete work.

The Contractor's laboratory designated for quality control testing shall have equipment necessary to test aggregates and concrete for the test methods listed in Table 1.

**Table 1**

AASHTO: T 2	Sampling Aggregates
AASHTO: T 19	Bulk Density ("Unit Weight") and Voids in Aggregates
AASHTO: T 22	Compressive Strength of Cylindrical Concrete Specimens
AASHTO: T 23	Making and Curing Concrete Test Specimens in the Field
AASHTO: T 27	Sieve Analysis of Fine and Coarse Aggregates
AASHTO: T 84	Specific Gravity and Absorption of Fine Aggregate
AASHTO: T 85	Specific Gravity and Absorption of Coarse Aggregate
AASHTO: T 119	Slump of Hydraulic Cement Concrete
AASHTO: T 121	Mass per Cubic Meter (Cubic Foot), Yield, and Air Content (Gravimetric) of Concrete
AASHTO: T 126	Making and Curing Concrete Test Specimens in the Laboratory
AASHTO: T 141	Sampling Freshly Mixed Concrete
AASHTO: T 152	Air Content of Freshly Mixed Concrete by Pressure Method *
AASHTO: T 196	Air Content of Freshly Mixed Concrete by the Volumetric Method *
AASHTO: T 231	Capping Cylindrical Concrete Specimens
AASHTO: T 248	Reducing Field Samples of Aggregate to Testing Size
AASHTO: T 255	Total Evaporable Moisture Content of Aggregate by Drying
ASTM: C 1064	Temperature of Freshly Mixed Portland Cement Concrete

\* Equipment necessary for either pressure or volumetric air content.

Testing equipment shall have been inspected by MDOT or through AAP. Testing equipment calibration files shall be made available upon request by the Engineer.

**S-804.02.9--Testing Personnel.** Technicians testing Portland cement concrete, for either acceptance or production control purposes, shall be certified by an accepted certification program. Recertification is required for each Class after five years. Certification requirements are listed in Table 2.

**Table 2**

Required Certification	Concrete Technician’s Tasks
MDOT Class I or ACI Grade I	Field Testing of Plastic Concrete, AASHTO Designation: T 23, T 119, T 121, T 141, T 152, T 196, and ASTM Designation: C 1064
MDOT Class II	Aggregate Sampling, Total Moisture, and Sieve Analysis, AASHTO Designation: T 2, T 27, T 248, T 255
MDOT Class III	Unit Weight and Voids of Aggregates, Specific Gravity*, Concrete Mix Design, Capping and Compressive Strength of Cylindrical Concrete Specimens*, AASHTO Designation: T 19, T 22, T 84, T 85, T 126, T 231

\* Technicians performing specific gravity or compressive strength tests shall be either Certified Class III or may be supervised by a Certified Class III Technician. Also, technicians performing these tests are required to demonstrate the specific gravity and compressive strength tests during the inspection of laboratory equipment by the MDOT Central Laboratory.

**S-804.02.10--Portland Cement Concrete Mix Design.** At least 30 days prior to production of concrete, the Contractor shall submit to the Engineer proposed concrete mix designs. Materials shall be from approved sources meeting the requirements of the Standard Specifications. Proportions for the mix designs shall be for the class concrete required by the contract plans and shall meet the requirements of the “Master Proportion Table for Structural Concrete Design” listed in Table 3. The concrete producer shall assign a permanent unique mix number to each mix design. Each mix design shall be field verified as required in S-804.02.10.3. Acceptable field verification data shall be required for final approval of a mix design. All concrete mix designs will be reviewed by the MDOT Central Laboratory, or other approved lab, prior to use. Concrete mix designs disapproved will be returned to the Contractor with a statement explaining the disapproval.

**Table 3****MASTER PROPORTION TABLE FOR STRUCTURAL CONCRETE DESIGN**

CLASS	COARSE AGGREGATE SIZE NO. *	MAXIMUM WATER/ CEMENTITIOUS RATIO **	SPECIFIED COMPRESSIVE STRENGTH (f'c)	MAXIMUM SLUMP ***	TOTAL AIR CONTENT
			<u>psi</u>	<u>inches</u>	<u>%</u>
AA	57 or 67	0.45	4000	3	3.0 to 6.0
A	57 or 67	0.45	4000	3	3.0 to 6.0
BB	57 or 67	0.50	3500	4	3.0 to 6.0
B	57 or 67	0.50	3500	4	3.0 to 6.0
C	57 or 67	0.55	3000	4	3.0 to 6.0
D	57 or 67	0.70	2000	4	3.0 to 6.0
F	67	0.40	5000	3	****
FX	67	(As required by special provisions)		3	****
S	57 or 67	0.45	3000	8	3.0 to 6.0
DS	67	0.45	4000	*****	****

\* Maximum size aggregate shall conform to the concrete mix design for the specified aggregate.

\*\* Maximum replacement of Portland cement by weight is 25% for fly ash or 50% for ground granulated blast furnace slag. The addition of fly ash as a replacement for cement will not be permitted in Type IP blended hydraulic cement, portland cement combined with ground granulated blast furnace slag or Type III portland cement when specified in the contract.

\*\*\* The slump may be increased up to 6 inches with an approved mid-range water reducer or up to 8 inches with an approved type F or G high range water reducer. A mid-range water reducer is classified as a water reducer that reduces the mix water a minimum of 8% when compared to a control mix with no admixtures. Minus slump requirements shall meet those set forth in Table 3 of AASHTO M157 specifications.

\*\*\*\* No entrained air except for pilings exposed to seawater.

\*\*\*\*\* Class DS Concrete for drilled shafts shall have an  $8 \pm 1$ -inch slump. In the event the free fall method of concrete placement is used, the slump shall be  $6 \pm 1$ -inch. No fly ash, ground granulated blast furnace slag, or F or G high range water reducers allowed in drilled shaft concrete. A slump retention admixture is required.



Either Type A, D, F, G, or mid-range chemical admixture, shall be used in all classes of concrete, except as noted above for drilled shaft concrete. Any combinations of water reducing admixtures shall be approved by the Engineer before their use.

**S-804.02.10.1--Proportioning of Portland Cement Concrete Mix Design.** Proportioning of Portland cement concrete shall be based on an existing mix of which the producer has field experience and documentation or based on a recently batched laboratory mix tested according to the required specifications.

**S-804.02.10.1.1--Proportioning on the Basis of Previous Field Experience of Trial Mixtures.** Where a concrete production facility has a record, based on at least 10 consecutive strength tests within the past 12 months from a mixture not previously used on MDOT or State Aid projects, the standard deviation shall be calculated. The record of tests from which the standard deviation is calculated shall:

- (a) Represent similar materials and conditions to those expected. Changes in materials and proportions within the test record shall not have been more closely restricted than those for the proposed work.
- (b) Represent concrete produced to meet a specified strength.
- (c) Consist of 10 consecutive tests, average of two cylinders per test, tested at 28 days.

The standard deviation,  $s$ , shall be calculated as:

$$s = \left[ \sum (X_i - \bar{X})^2 \div (N - 1) \right]^{1/2}$$

where:

$X_i$  = the strength result of an individual test

$\bar{X}$  = the average of individual tests in the series

$N$  = number of tests in the series

When the concrete production facility does not have a record of tests for calculation of standard deviation, as required in the above formula, the requirements of S-804.02.10.1.2 shall govern.

The required average compressive strength ( $f'_{cr}$ ) used as the basis for selection of concrete proportions shall conform to the inequality listed below, while using a standard deviation,  $s$ , calculated as shown above.

$$\bar{X} \geq f'_{cr}$$

where:

$$f'_{cr} = f'_c + 1.43s$$

where:

- $f'_c$  = specified compressive strength of concrete, psi  
 $f'_{cr}$  = required average compressive strength of concrete, psi  
 $s$  = standard deviation, psi

1.43 represents the Lower Quality Index necessary to assure that 93% of compressive strength tests are above  $f'_c$ .

**S-804.02.10.1.2--Proportioning on the Basis of Laboratory Trial Mixtures.** When an acceptable record of field test results is not available, concrete proportions shall be established based on laboratory trial mixtures meeting the following restrictions:

- (a) The combination of materials shall be those intended for use in the proposed work.
- (b) Trial mixtures having proportions and consistencies suitable for the proposed work shall be made using the ACI 211.1 as a guide to proportion the mix design.
- (c) Trial mixtures shall be designed to produce a slump within  $\pm 3/4$  in. of the maximum permitted, and for air-entrained concrete,  $6.0 \pm 0.5$  percent total air content. The temperature of freshly mixed concrete in trial mixtures shall be reported.
- (d) For each proposed mixture, at least three compressive test cylinders shall be made and cured in accordance with AASHTO Designation: T 126. Each change of water-cement ratio shall be considered a new mixture. The cylinders shall be tested for strength in accordance with AASHTO Designation: T 22 and shall meet the required 28 day strength.
- (e) The required average strength of laboratory trial mixes shall exceed  $f'_c$  by 1200 psi for concrete mix designs less than 5000 psi and by 1400 psi for concrete mix designs of 5000 psi or more.

- (f) The laboratory trial batch mixtures shall have been made within the previous 12 months before being submitted for approval and shall not have been previously used on MDOT or State Aid projects.

**S-804.02.10.2--Documentation of Average Strength.** Documentation that the proposed concrete proportions will produce an average strength equal to or greater than the required average shall consist of the strength test records from field tests or results from laboratory trial mixtures.

**S-804.02.10.3--Field Verification of Concrete Mix Design.** Concrete mix designs will only be tentatively approved pending field verification. Mix designs may be transferred to other projects without additional field verification testing, once the mix design has passed the field verification process.

The Contractor's Certified Quality Control Technicians shall test each concrete mix design upon the first placement of the mix. Aggregates and concrete tests during the first placement shall be as follows:

**Aggregates**

Bulk Specific Gravity  
Moisture  
Gradation

**Concrete**

Water Content  
Slump  
Air Content  
Unit Weight  
Yield

The mix shall be verified to yield within 2.0% of the correct volume when all the mix water is added to the batch, producing a slump within a minus 1½ inches tolerance, or minus 2½ inches with Type F or G chemical admixture, of the maximum permitted and total air content within a minus 1½ percent tolerance of the maximum allowable air content listed in Table 3. The mix shall be adjusted and retested, if necessary, on subsequent placements until the above mentioned properties are met. If the requirements of yield, slump, or air are not met after three attempts, subsequent field verification testing shall not be permitted, and the mix design shall not be used until the requirements listed above are met. Any mix design adjustments, changes in the mix proportions, are to be made by a Class III Certified Technician representing the Contractor. After the mix design has been verified and adjustments made, verification test results will be reviewed by the Engineer.

**S-804.02.10.4--Adjustments of Mixtures Proportions.** After ten compressive tests have been performed for which a standard deviation is calculated, the mix design may be adjusted provided the average strength ( $\bar{X}$ ) complies with the inequality in S-804.02.10.1.1 and the adjusted mix design satisfies the water/cementitious ratio requirement listed in Table 3. Any adjustments of the concrete mix design shall necessitate repeat of field verification procedure as described in S-804.02.10.3 and approval by the Engineer.

**S-804.02.11--Concrete Batch Plants.** The concrete batch plant and assigned mixer trucks shall be on the list of approved concrete batch plants and mixer trucks. For large quantity projects the plant shall meet the requirements for an automatic system capable of recording batch weights. It shall also have automatically moisture compensation for the fine aggregate.

For projects, with the total volume less than two thousand(2000) cubic yards, the plant can be equipped for manual batching with a fine aggregate moisture meter visible to the plant operator.

The concrete batch plant shall have available adequate facilities to cool concrete during hot weather.

**S-804.02.12--Contractor's Quality Control.** The Contractor shall provide and maintain a quality control program that will provide reasonable assurance that all materials and products submitted to the Engineer for acceptance will conform to the contract requirements, whether manufactured or processed by the Contractor or procured from suppliers, subcontractors, or vendors.

The Contractor's Quality Control program shall implement the minimum quality control requirements shown in Table 4, "Contractor's MINIMUM REQUIREMENTS FOR QUALITY CONTROL". The quality control activities shown in the table are considered to be normal activities necessary to control the production and placing of a given product or material at an acceptable quality level. To facilitate the Engineer's activities, all completed gradation samples shall be retained for a minimum of sixty (60) days by the Contractor or until further disposition is designated by the Engineer.

The Contractor shall perform, or have performed, the inspections and tests required to substantiate product conformance to contract document requirements and shall also perform, or have performed, all inspections and tests otherwise required.

The Contractor's Quality Control program shall encompass the requirements of AASHTO Designation: M 157 into concrete production and control, equipment requirements, testing, and batch ticket information. The requirement of AASHTO Designation: M 157, Section 11.7 shall be followed except, on arrival to the job site, a maximum of 1½ gallons of water per cubic yard shall be allowed to be added to bring the slump within the required limits. Water shall not be added at a later time.

The Contractor's quality control inspections and tests shall be documented and shall be available for review by the Engineer throughout the life of the contract.

As set out in these specifications, quality control sampling and testing performed by the Contractor will be used by the Engineer for determination of acceptability of the concrete.

The Contractor shall maintain standard equipment and qualified personnel as required to assure conformance to contract requirements.

**S-804.02.12.1--Quality Control Plan.** The Contractor shall prepare a Quality Control Plan which shall identify the personnel responsible for the Contractor's quality control including the company official who will act as liaison with the Engineer. The Quality Control Plan shall be submitted in writing to the Engineer for approval 30 days prior to the production of concrete.

The class(es) of concrete involved will be listed separately. If an existing mix design(s) is to be used, the mix design number(s) as previously approved shall be listed.

It is intended that sampling and testing be in accordance with standard methods and procedures, and that measuring and testing equipment be standard and properly calibrated. If alternative sampling methods and procedures, and inspection equipment are to be used, they shall be detailed in the Quality Control Plan.

**S-804.02.12.1.1--Elements of Plan.** The Plan shall address all elements that affect the quality of the structural concrete including, but not limited to, the following:

- (a) Stockpile Management
- (b) Procedures for Corrective Actions for Noncompliance of Specifications
- (c) Procedure for Controlling Concrete Temperatures

**S-804.02.12.2--Personnel Requirements.** The Contractor's Designated Certified Technician shall perform and use quality control tests and other quality control practices to assure that delivered materials and proportioning meet the requirements of the mix design including temperature, slump, air content, and strength and shall periodically inspect all equipment used in transporting, proportioning, and mixing.

The Contractor's Designated Technician shall periodically inspect all equipment used placing, consolidating, finishing, and curing to assure it is operating properly and that placement, consolidation, finishing, and curing conform to the mix design and other contract requirements.

**S-804.02.12.3--Documentation.** The Contractor shall maintain adequate records of all inspections and tests. The records shall indicate the nature and number of observations made, the number and type of deficiencies found, date and time of samples taken, the quantities approved and rejected, and the nature of corrective action taken as appropriate. The Contractor's documentation procedures will be subject to approval of the Engineer prior to the start of the work and to compliance checks during the progress of the work.

All conforming and nonconforming inspections and test results shall be kept complete and shall be available at all times to the Engineer during the performance of the work. Forms shall be on a computer-acceptable medium. Batch tickets and gradation data shall be documented in accordance with State Aid requirements. Copies shall be submitted to the Engineer as the work progresses.

Test data for Portland cement concrete, including gradation, shall be charted in accordance with the applicable requirements.

The Contractor may use additional control charts as deemed appropriate. It is normally expected that testing and charting will be completed within 24 hours after sampling.

All charts and records documenting the Contractor's quality control inspections and tests shall become the property of the Engineer upon completion of the work.

**S-804.02.12.4--Corrective Action.** The Contractor shall take prompt action to correct conditions that have resulted, or could result, in the delivery to the Project of materials and products that do not conform to the requirements of the contract documents. All corrective actions shall be documented.

**S-804.02.12.5--Non-Conforming Materials.** The Contractor shall establish and maintain an effective and positive system for controlling non-conforming material, including procedures for its identification, isolation and disposition. Reclaiming or reworking of non-conforming materials shall be in accordance with procedures acceptable to the Engineer.

All non-conforming materials and products shall be positively identified to prevent use, shipment, and intermingling with conforming materials and products. Holding areas, mutually agreeable to the Engineer and the Contractor, shall be provided by the Contractor.

**TABLE 4  
CONTRACTOR'S MINIMUM REQUIREMENTS FOR QUALITY CONTROL**

Portland Cement Concrete		
Control Requirement	Frequency	AASHTO/ ASTM Designation
<b>A. PLANT AND TRUCKS</b>		
1. Mixer Blades	Monthly	
2. Scales		
a. Tared	Daily	
b. Calibrate	Every 6 months	
c. Check Calibration	Weekly	
3. Gages & Meters - Plant & Truck		
a. Calibrate	Every 6 months	
b. Check Calibration	Weekly	
4. Admixture Dispenser		
a. Calibrate	Every 6 months	
b. Check Operation & Calibration	Daily	
<b>B. AGGREGATES</b>		
1. Sampling		T 2
2. Fine Aggregate		
a. Gradation / FM	250 yd <sup>3</sup> Concrete	T 27
b. Moisture	Check Meter Against Test Results Weekly	T 255
c. Specific Gravity / Absorption	2500 yd <sup>3</sup> Concrete (At least one per project)	T 84
3. Coarse Aggregates		
a. Gradation / FM	250 yd <sup>3</sup> Concrete	T 27
b. Moisture	Minimum of once daily or more as needed to control production	T 255
c. Specific Gravity / Absorption	2500 yd <sup>3</sup> Concrete (At least one per project)	T 85
<b>C. PLASTIC CONCRETE</b>		
1. Sampling		T 141
2. Air Content	First load then one per 50 yd <sup>3</sup>	T 152 or T 196
3. Slump	First load then one per 50 yd <sup>3</sup>	T 119
4. Compressive Strength	One set ( two cylinders ) for 0-100 yd <sup>3</sup> inclusive and one set for each additional 100 yd <sup>3</sup> or fraction thereof for each class concrete delivered and placed on a calendar day from a single supplier. A test shall be the average of two cylinders.	T 22, T 23, T 231
5. Yield	Each 400 yd <sup>3</sup>	T 121
6. Temperature	With each sample	C 1064

**S-804.02.13--Quality Assurance Sampling and Testing.** Quality Assurance (QA) inspection and testing will be provided by the Engineer to assure that the Contractor's Quality Control (QC) testing meets the requirements of these specifications.

Acceptance of the material is based on the inspection of the construction, monitoring of the Contractor's quality control program, QC test results, and the comparison of the QA test results with the QC test results. The Engineer may use the results of the Contractor's QC tests as a part of the acceptance procedures instead of the results of QA tests, provided:

- (a) The Engineer's inspection and monitoring activities indicate that the Contractor is following the approved Quality Control program and, respectively,
- (b) For aggregates, the results from the Contractor's QC and the Engineer's QA testing of aggregate gradations compare by both meeting the aggregate type's gradation requirements;
- (c) For concrete, the Contractor's QC and Engineer's QA testing of concrete compressive strengths compare within 990 psi provided both the QC and QA test results are equal to or exceed the minimum compressive strength requirements.

The minimum frequency for QA testing of aggregate and plastic concrete by the Engineer will follow the frequencies listed in Table 5, "MINIMUM REQUIREMENTS FOR QUALITY ASSURANCE".



**TABLE 5**  
**MINIMUM REQUIREMENTS FOR QUALITY ASSURANCE**

Quality Assurance Tests	Frequency	AASHTO/ASTM Designation
<b>A. AGGREGATES</b> 1. Sampling 2. Fine Aggregate Gradation and FM 3. Coarse Aggregates Gradation and FM	250 yd <sup>3</sup> Concrete  250 yd <sup>3</sup> Concrete	T 2 T 27  T 27
<b>B. PLASTIC CONCRETE</b> 1. Sampling 2. Air Content 3. Slump 4. Compressive Strength  5. Temperature	Every 100 yd <sup>3</sup> Every 100 yd <sup>3</sup> One set (two cylinders) for every 100 yd <sup>3</sup> inclusive. A test shall be the average of two cylinders. With each sample	T 141 T 152 or T 196 T 119 T 22, T 23, T231  C 1064

Periodic inspection by the Engineer of the Contractor's QC testing and production will continue through the duration of the project. Weekly reviews will be made of the Contractor's QC records and charts.

For aggregates, comparison of data of the Contractor's QC aggregate gradation test results to those of the Engineer's QA aggregate gradation test results will be made monthly during concrete production periods according to State Aid Standard Operating Procedures. When it is determined that the Contractor's QC test results of aggregate gradations are comparative to that of the Engineer's QA test results, then the Engineer will use the Contractor's QC results as a basis for acceptance of the aggregates and the Engineer's QA testing frequency of aggregates may be reduced to a frequency of no less than three QA tests to every 10 QC tests. If the Contractor's QC aggregate gradation test results fail to compare to those of the Engineer's QA aggregate gradation test results, the Engineer's testing for aggregate gradations will revert to the frequency shown in Table 5 for aggregates until the Contractor's and Engineer's aggregate gradation test data compare.

For concrete compressive strength, comparison of data of the Contractor's QC compressive strength test results to those of the Engineer's QA compressive strength test results will be made monthly during concrete production periods according to State Aid Standard Operating Procedures. When it is determined that the Contractor's QC test results of concrete compressive strengths are comparative to that of the Engineer's QA test results, then the Engineer will use the Contractor's QC results as a basis for acceptance of the concrete and the Engineer's QA testing frequency of concrete compressive strengths may be reduced to a frequency of no less than three QA tests to every 10 QC tests. If the Contractor's QC compressive strength test results fail to compare to those of the Engineer's QA compressive strength test results, the Engineer's testing will revert to the frequency shown in Table 5 for plastic concrete until the Contractor's and Engineer's compressive strength test data compare.

**S-804.02.13.1--Basis of Acceptance.**

**S-804.02.13.1.1--Slump.** Slump of plastic concrete shall meet the requirements of Table 3: MASTER PROPORTION TABLE FOR STRUCTURAL CONCRETE DESIGN. A check test shall be made on another portion of the sample before rejection of any load.

**S-804.02.13.1.2--Air.** Total air content of concrete shall be within the specified range for the class of concrete listed in Table 3: MASTER PROPORTION TABLE FOR STRUCTURAL CONCRETE DESIGN. A check test shall be made on another portion of the sample before rejection of any load.

**S-804.02.13.1.3--Yield.** If the yield of the concrete mix design is more than plus or minus 3% of the designed volume, the mix shall be adjusted by a Class III Certified Technician representing the Contractor to yield the correct volume plus or minus three percent ( $\pm 3\%$ ). If batching of the proportions of the mix design varies outside the batching tolerance range of the originally approved proportions by more than the tolerances allowed in S-804.02.13.1, the new proportions shall be field verified per S-804.02.10.3.

**S-804.02.13.1.4--Temperature.** Cold weather concreting shall follow the requirements of S-804.03.16.1. Hot weather concreting shall follow the requirements of S-804.03.16.2 with a maximum concrete temperature of 95°F for Class DS concrete containing a slump retention admixture and for concrete mixes containing pozzolanic materials as a replacement of Portland cement. For other classes of concrete without pozzolanic materials, the maximum concrete temperature shall be 90°F. Concrete with a temperature more than the maximum allowable temperature shall be rejected and not used in State Aid work.

**S-804.02.13.1.5--Compressive Strength.** Laboratory cured concrete compressive strength tests shall conform to the specified strength ( $f'_c$ ) listed in the specifications. Concrete represented by compressive strength test below the specified strength ( $f'_c$ ) may be removed and replaced by the Contractor. If the Contractor elects not to remove the material, it will be evaluated by the Engineer as to the adequacy for the use intended. All concrete evaluated as unsatisfactory for the intended use shall be removed and replaced by the Contractor at no additional cost to the Project. For concrete allowed to remain in place, reduction in payment will be as follows:

When the evaluation indicates that the work may remain in place, a percent reduction in pay will be assessed based on a comparison of the deficient 28-day test result to the specified strength. The Engineer will provide for an adjustment in pay as follows for the material represented by the test result.

Total Pay on Material in Question = Unit Price - (Unit Price x % Reduction)

$$\% \text{ Reduction} = \frac{(f'_c - X)}{f'_c} \times 100$$

where:

$f'_c$  = Specified 28-day compressive strength, psi

X = Individual compressive strength below  $f'_c$ , psi

If a project has more than 2000 cubic yards of concrete, MDOT Specifications will be followed.

**S-804.02.14--Dispute Resolution.** Disputes over variations between Contractor's QC test results and the Engineer's QA test results shall be resolved at the lowest possible level. When there are significant discrepancies between the QC test results and the QA test results, the Contractor's Quality Control Manager, the Engineer, and the State Aid District Engineer shall look for differences in the procedures, and correct the inappropriate procedure before requesting a third party resolution.

If the dispute cannot be resolved at the project level, the State Aid Engineer will serve as a third party to resolve the dispute. The State Aid Engineer's decision shall be binding.

The Contractor shall be responsible for the cost associated with the third party resolution if the final decision is such that the Engineer's QA test results were correct. Likewise, the Project fund will be responsible for the cost when the final decision is such that the Contractor's QC test results were correct.

**S-804.03--Construction Requirements.****S-804.03.1--Measurement of Materials.**

**S-804.03.1.1--General.** The accuracy for measuring materials shall be in accordance with AASHTO Designation: M 157.

**S-804.03.1.2--Measurement by Weighing.** Except when otherwise specified or authorized, materials shall be measured by weighing. The apparatus provided for weighing materials shall be suitably designed and constructed for this purpose. Cement and aggregates shall be weighed separately. Cement in standard bags need not be weighed, but bulk cement shall be weighed. The mixing water shall be measured by volume or by weight. All measuring devices shall be subject to approval.

**S-804.03.2--Blank.****S-804.03.3--Blank.**

**S-804.03.4--Hand Mixing.** Hand mixing of concrete will not be allowed.

**S-804.03.5--Delivery.** The plant supplying concrete shall have sufficient capacity and transporting apparatus to insure continuous delivery at the rate required. The rate of delivery shall be such as to provide for the proper continuity in handling, placing, and furnishing of the concrete. The rate shall be such that the interval between batches shall not exceed 20 minutes. The methods of delivering and handling the concrete shall be that which will facilitate placing with minimum rehandling and without damage to the structure or the concrete.

**S-804.03.6--Handling and Placing Concrete.**

**S-804.03.6.1--General.** Prior to placing concrete, all reinforcement shall have been accurately placed in the position shown on the plans and fastened as set out in S-805. All sawdust, chips, and other construction debris and extraneous matter shall have been removed from the interior of the forms. Temporary struts, braces, and stays holding the forms in correct shape and alignment shall be removed when the concrete placing has reached an elevation rendering their service unnecessary. These temporary members shall be entirely removed from the forms and shall not be buried in the concrete.

No concrete shall be placed until the forms and reinforcement have been inspected.

Except as provided for truck mixers and truck agitators, concrete shall be placed in the forms within 30 minutes after the time that the cement is first added to the mix.

Concrete shall be placed so as to avoid segregation of materials and displacement of reinforcement. The use of troughs, chutes, and pipes over 25 feet in length for gravity conveyance of concrete to the forms, will not be permitted except when authorized by the Engineer and subject to the production of quality concrete.

Only approved mechanical conveyors will be permitted.

Open troughs and chutes shall be metal or metal lined. The use of aluminum pipes, chutes, or other devices made of aluminum that come into direct contact with the concrete shall not be used. Where steep slopes are required, the chutes shall be equipped with baffles or be in short sections that change the direction of movement.

All chutes, troughs, and pipes shall be kept clean and free from coatings of hardened concrete by thoroughly flushing with water after each run. Water used for flushing shall be discharged clear of the structure.

When placing operations involve dropping the concrete more than five feet, it shall be deposited through sheet metal or other approved pipes to prevent segregation and unnecessary splashing. The pipes shall be made in sections to permit discharging and raising as the placement progresses. A non-jointed pipe may be used if sufficient openings of the proper size are provided to allow for the flow of the concrete into the shaft. As far as practicable, the pipes shall be kept full of concrete during placing, and their ends shall be kept buried in the newly placed concrete.

Except as hereinafter provided, concrete shall be placed in horizontal layers not more than 12 inches thick. When, with the Engineer's approval, less than the complete length of a layer is placed in one operation, it shall be terminated in a vertical bulkhead. Each layer shall be placed and compacted before the preceding layer has taken its initial set and shall be compacted so as to avoid the formation of a construction joint with the preceding layer.

**S-804.03.6.2--Consolidation.** Concrete, during and immediately after depositing, shall be thoroughly consolidated by the use of approved mechanical vibrators and suitable spading tools. Hand spading alone will be permitted on small structural members such as railing and small culvert headwalls. Mechanical vibration of concrete shall be subject to the following:

- A. The vibration shall be internal unless special authorization of other methods is given by the Engineer or as provided herein.
- B. In general, vibrators shall be a type and design approved by the Engineer. They shall be capable of vibration frequencies of at least 4500 impulses per minute.
- C. The intensity of vibration shall be such as to visibly affect a mass of concrete of one inch slump over a radius of at least 18 inches.
- D. The Contractor shall provide sufficient vibrators to properly compact each batch immediately after it is placed in the forms.
- E. Vibrators shall be manipulated so as to thoroughly work the concrete around the reinforcement and embedded fixtures and into the corners and angles of the forms.

Vibration shall be applied at the point of deposit and in the area of freshly deposited concrete. The vibrators shall be inserted into and withdrawn out of the concrete slowly. The vibration shall be of sufficient duration and intensity to thoroughly compact the concrete, but shall not be continued so as to cause segregation. Vibration shall not be continued at any one point to the extent that localized areas of grout are formed.

Application of vibrators shall be at points uniformly spaced and not farther apart than twice the radius over which the vibration is visibly effective.

- F. Vibration shall not be applied directly or through the reinforcement to sections or layers of concrete which have taken initial set. It shall not be used to make concrete flow in the forms over distances so great as to cause segregation, and vibrators shall not be used to transport concrete in the forms.
- G. Vibration shall be supplemented by spading as necessary to insure smooth surfaces and dense concrete along form surfaces, in corners, and in locations impossible to reach with vibrators.
- H. These provisions shall apply to the filler concrete for steel grid floors except that the vibrator shall be applied to the steel.
- I. These provisions shall apply to precast piling, concrete cribbing, and other precast members except that, if approved by the Engineer, the manufacturer's methods of vibrations may be used.

When hand spading is used for consolidation, a sufficient number of workmen with spading tools shall be provided. They will be required to flush a thin layer of mortar to all the surfaces and thoroughly and satisfactorily consolidate the concrete.

The entire operation of depositing and consolidating the concrete shall be conducted so that the concrete shall be smooth and dense and free from honeycomb or pockets of segregated aggregate.

**S-804.03.6.3--Discontinuance of Placing.** When placing is temporarily discontinued, the concrete, after becoming firm enough to retain its form, shall be cleaned of laitance and other objectionable material to a sufficient depth to expose sound concrete. To avoid visible joints insofar as possible upon exposed faces, the top surface of the concrete adjacent to the forms shall be smoothed with a trowel. Where a "feather edge" might be produced at a construction joint, such as in the sloped top surface of a wing wall, an inset form work shall be used in the preceding layer to produce a blocked out portion that will provide an edge thickness of at least six inches in the succeeding layer. Work shall not be discontinued within 18 inches of the top of any face unless provision has been made for a coping less than 18 inches thick. In this case and if permitted by the Engineer, the construction joint may be made at the under side of the coping.

Immediately following the discontinuance of placing concrete, all accumulations of mortar splashed on the reinforcement and the surface of forms shall be removed. Dried mortar chips and dust shall not be puddled into the unset concrete. If the accumulations are not removed prior to the concrete becoming set, care shall be exercised not to break or injure the concrete-steel bond at and near the surface of the concrete while cleaning the reinforcement. After initial set the forms shall not be jarred, and no strain shall be placed on the ends of projecting reinforcement until the concrete has sufficiently set to insure against any damage by such jarring or strain.

**S-804.03.6.4--Placing Bridge Concrete.** The method and sequence of placing concrete shall conform to the provisions and requirements set forth for the particular type of construction.

**S-804.03.6.4.1--Foundations and Substructures.** Concrete seals shall be placed in accordance with S-804.03.9. All other concrete for foundations shall be poured in the dry unless otherwise stipulated or authorization is given in writing by the Engineer to do otherwise. Concrete shall not be placed in foundations until the foundation area has been inspected and approved.

Unless otherwise specified, the placement of concrete in the substructure shall be in accordance with the general requirements of S-804.03.6.

Unless otherwise directed, concrete in columns shall be placed in one continuous operation, and shall be allowed to set at least 12 hours before the caps are placed.

**S-804.03.6.4.2--Superstructure.** For simple spans, concrete shall preferably be deposited by beginning at the center of the span and working toward the ends. For continuous spans, concrete shall be deposited as shown on the plans. Concrete in girders shall be uniformly deposited for the full length of the girder and brought up evenly in horizontal layers.

Unless otherwise permitted by the Engineer, concrete shall not be placed in the superstructure until the column forms have been stripped sufficiently to determine the character of the concrete in the columns. Unless otherwise permitted by the Engineer, the load of the superstructure shall not be placed on pile bents until the caps have been in place at least 7 days and shall not be placed on other types of bents until the bents have been in place at least 14 days.

In placing concrete around steel shapes, it shall be placed on one side of the shape until it flushes up over the bottom flange of the shape on the opposite side, after which it shall be placed on both sides to completion.

Concrete in girder haunches less than three feet in height shall be placed at the same time as that in the girder stem. Whenever a haunch or fillet has a height of three feet or more at the abutment or columns, the haunch and the girder shall be poured in three successive stages: first, up to the lower side of the haunch; second, to the lower side of the girder; and third, to completion.

Except when intermediate construction joints are specified, concrete in slab, T-beam, or deck-girder spans shall be placed in one continuous operation for each span.

The floors and girders of through-girder superstructures shall be placed in one continuous operation unless otherwise specified, in which case special shear anchorage shall be provided to insure monolithic action between girder and floor.

Concrete in box girders shall be placed as shown on the plans.

Concrete shall not be chuted directly into the forms of the span and shall be placed continuously with sufficient speed to be monolithic and to allow for finishing before initial set.

**S-804.03.7--Pneumatic Placing.** Pneumatic placing of concrete will be permitted only if specified in the contract or if authorized by the Engineer. The equipment shall be so arranged that no vibrations result which might damage freshly placed concrete.



Where concrete is conveyed and placed by pneumatic means the equipment shall be suitable in kind and adequate in capacity for the work. The machine shall be located as close as practicable to the place of deposit. The position of the discharge end of the line shall not be more than 10 feet from the point of deposit. The discharge lines shall be horizontal or inclined upwards from the machine. At the conclusion of placement the entire equipment shall be thoroughly cleaned.

**S-804.03.8--Pumping Concrete.** Placement of concrete by pumping will be permitted only if specified in the contract or if authorized in writing by the Engineer. If used, the equipment shall be arranged so that no vibrations result which might damage freshly placed concrete.

Where concrete is conveyed and placed by mechanically applied pressure, the equipment shall be suitable in kind and adequate in capacity for the work. The operation of the pump shall be such that a continuous stream of concrete without air pockets is produced. When pumping is completed, the concrete remaining in the pipe line, if it is to be used, shall be ejected in such a manner that there will be no contamination of the concrete or separation of the ingredients. After this operation, the entire equipment shall be thoroughly cleaned.

The use of aluminum pipe as a conveyance for the concrete will not be permitted.

**S-804.03.9--Depositing Concrete Under Water.** Concrete shall not be deposited in water except with the approval of the Engineer.

Concrete deposited under water shall be Class S.

Concrete deposited under water shall be carefully placed in a compact mass in its final position by means of a tremie, a bottom dump bucket, or other approved method and shall not be disturbed after being deposited. Special care shall be exercised to maintain still water at the point of deposit. No concrete shall be placed in running water and all form work designed to retain concrete under water shall be water-tight. The consistency of the concrete shall be carefully regulated, and special care shall be exercised to prevent segregation of materials.

Concrete seals shall be placed continuously from start to finish, and the surface of the concrete shall be kept as nearly horizontal as practicable at all times. To insure thorough bonding, each succeeding layer of a seal shall be placed before the preceding layer has taken initial set.

When a tremie is used, it shall consist of a tube having a diameter of at least 10 inches and constructed in sections having flanged couplings fitted with gaskets. The means of supporting the tremie shall be such as to permit the free movement of the discharge over the entire top surface of the work and to permit it to be lowered rapidly when necessary to choke off or retard the flow of concrete. The discharge end shall be closed at the start of the work so as to prevent water entering the tube and shall be entirely sealed. The tremie tube shall be kept full to the bottom of the hopper. When a batch is dumped into the hopper, the flow of concrete shall be induced by slightly raising the discharge end, always keeping it in the deposited concrete. The flow is then stopped by lowering the tremie. The flow shall be continuous until the work is completed.

Depositing of concrete by the drop bottom bucket method shall conform to the following: The top of the bucket shall be open. The bottom doors shall open freely downward and outward when tripped. The bucket shall be completely filled and slowly lowered to avoid backwash. It shall not be dumped until it rests on the surface upon which the concrete is to be deposited and when discharged shall be withdrawn slowly until well above the concrete.

Dewatering may proceed when the concrete seal is sufficiently hard and strong. As a general rule, this time will be 48 hours for concrete made with high-early-strength cement and three days for concrete made with other types of cement. All laitance and other unsatisfactory material shall be removed from the exposed surface by scraping, chipping, or other means which will not injure the surface of the concrete.

#### **S-804.03.10--Construction Joints.**

**S-804.03.10.1--General.** Unless otherwise approved by the Engineer, construction joints shall be made only where located on the plans or shown in the pouring schedule. If not detailed on the plans, or in the case of emergency, construction joints shall be placed as directed by the Engineer. Shear keys or inclined reinforcement shall be used where necessary to transmit shear or to bond the two sections together.

For continuous spans, bridge deck concrete shall be deposited as shown on the plans. Deviation from the pouring schedule shown in the plans is not permitted.

**S-804.03.10.2--Bonding.** Before depositing new concrete on or against concrete which has hardened, the forms shall be retightened. The surface of the hardened concrete shall be roughened as required by the Engineer and in a manner that will not leave loosened particles of aggregate or damaged concrete at the surface. It shall be thoroughly cleaned of foreign matter and laitance and saturated with water. When directed by the Engineer, the cleaned and saturated surfaces, including vertical and inclined surfaces, shall first be thoroughly covered with a coating of mortar or neat cement grout against which the new concrete shall be placed before the grout has attained its initial set.

The placing of concrete shall be carried continuously from joint to joint. The face edges of all joints which are exposed to view shall be carefully finished, true to line and elevation.

In order to bond successive courses suitable depressed or raised keys of the designated size shall be constructed. Raised keys shall be monolithic with the concrete of the lower course.

**S-804.03.11--Concrete Exposed to Seawater.** Unless otherwise specifically provided, concrete for structures exposed to seawater shall be Class AA concrete as referenced in S-804.02.10. The clear distance from the face of the concrete to the nearest face of reinforcing steel shall be at least four inches. The mixing time and the water content shall be carefully controlled and regulated so as to produce concrete of maximum impermeability. The concrete shall be thoroughly compacted, and stone pockets shall be avoided. No construction joints shall be formed between the levels of extreme low water and extreme high water as determined by the Engineer. Between these levels, seawater shall not come in direct contact with the new concrete until at least 30 days have elapsed. The surface concrete as left by the forms shall be left undisturbed.

**S-804.03.12--Blank.**

**S-804.03.13--Falsework.** The Contractor shall submit to the Engineer two copies of structural design analysis and detail drawings, which show the method of falsework or centering. These designs and detail plans shall be prepared and bear the seal of a Registered Professional Engineer with experience in falsework design.

Falsework plans shall include falsework elevations together with all other dimensions and details which is considered necessary for the construction.

Other pertinent data needed is size and spacing of all falsework members and minimum bearing requirements for false piles.

Upon completion of falsework erection, the Registered Professional Engineer shall certify that the erected falsework is capable of supporting the load for construction.

Falsework piling shall be spaced and driven so that the bearing value of each pile is sufficient to support the load that will be imposed upon it. The bearing value of the piles should be calculated according to the appropriate formula given in S-803.

For designing falsework and centering, a weight of 150 pounds per cubic foot shall be assumed for green concrete. All falsework shall be designed and constructed to provide the necessary rigidity and to support the loads without appreciable settlement or deformation. The Contractor may be required to employ screw jacks or hardwood wedges to take up slight settlement in the falsework either before or during the placing of concrete. An allowance shall be made for anticipated compressibility of falsework and for the placement of shims, wedges, or jacks to produce the permanent structural camber shown on the plans. If during construction, any weakness develops and the falsework shows any undue settlement or distortion, the work shall be stopped, the part of the structure affected removed, and the falsework strengthened before work is resumed. Falsework which cannot be founded on a satisfactory footing shall be supported on piling, which shall be spaced, driven, and removed, as referenced in S-804.03.15, in a manner approved by the Engineer.

All structures built across a public street or highway on which maintenance of traffic is required, shall have falsework so arranged that a vertical clearance of at least 12' 6" is provided. Unless otherwise specified, a horizontal clearance of at least the width of the traveled way shall be provided at all times. If the vertical clearance is less than 13' 6" or the horizontal clearance is less than the full crown width of the roadway, the Contractor shall install and maintain appropriate safety devices, clearance signs and warning lights, and shall notify the Engineer sufficiently in advance of restricting the clearance for the Engineer to advise the appropriate authorities. All traffic control and safety devices shall be in accordance with the Manual on Uniform Traffic Control Devices (MUTCD).

#### **S-804.03.14--Forms.**

**S-804.03.14.1--General.** Forms shall be wood, metal, or other material approved by the Engineer. All forms shall be built mortar-tight and sufficiently rigid to prevent distortion due to pressure of the concrete and other loads incident to the construction operations. Forms shall be constructed and maintained so as to prevent warping and the opening of joints due to shrinkage. The forms shall be substantial and unyielding and shall be so designed that the finished concrete will conform to the proper dimensions and contours. The design of the forms shall take into account the effect of vibration of concrete as it is placed.

Minimum requirements for slab overhang forms shall be 3/4-inch plywood supported on 2-inch x 6-inch S4S wood timbers placed flatwise on 16-inch centers.

Adjustable brackets for support of slab overhang forms shall be spaced at a maximum distance of 3' 0" center to center unless specifically approved otherwise. Grade points for forms shall coincide with the location of the adjustable form brackets.

Forms for surfaces exposed to view shall be of uniform thickness with a smooth inside surface of an approved type. Joints in forms for exposed surfaces shall be closely fitted to eliminate fins, stone pockets, or other variations in the surface of the concrete which would mar a smooth and uniform texture.

Forms shall be filleted at all sharp corners and shall be given a bevel or draft in the case of all projections, such as girders and copings, to insure easy removal.

Metal ties or anchorages within the forms shall be so constructed as to permit their removal, without injury to the concrete, to a depth of at least the reinforcing steel clearance shown on the plans. In case ordinary wire ties are permitted, all wires, upon removal of the forms, shall be cut back at least 1/4 inch from the face of the concrete with chisels or nippers. Nippers shall be used for green concrete. All fittings for metal ties shall be designed so that upon their removal the cavities which are left will be the smallest practicable size. The cavities shall be filled with cement mortar and the surface left sound, smooth, even, and uniform in color.

Forms shall be set and maintained to the lines designated until the concrete is sufficiently cured for form removal. Forms shall remain in place for periods which shall be determined as hereinafter specified. If forms are deemed to be unsatisfactory in any way, either before or during the placing of concrete, the Engineer will order the work stopped until the defects have been corrected.

The shape, strength, rigidity, water-tightness, and surface smoothness of reused forms shall be maintained at all times. Warped or bulged lumber shall be resized before being reused. Forms which are unsatisfactory in any respect shall not be reused. Access to the lower portions of forms for narrow walls and columns shall be provided for cleaning out extraneous material immediately before placing the concrete.

All forms shall be treated with an approved oil or saturated with water immediately before placing the concrete. For rail members or other members with exposed faces, the forms shall be treated only with an approved oil to prevent the adherence of concrete. Any material which will adhere to or discolor the concrete shall not be used.

When metal forms are used they shall be kept free from rust, grease, or other foreign matter which will discolor the concrete. They shall be of sufficient thickness and so connected that they will remain true to shape and line, and shall conform in all respects as herein prescribed for mortar tightness, filleted corners, beveled projections, etc. They shall be constructed so as to insure easy removal without injury to concrete. All inside bolt and rivet heads shall be countersunk.

All chamfer strips shall be dressed, straight, and of uniform width and shall be maintained as such at all times.

**S-804.03.14.2--Stay-In-Place Metal Forms.** The use of stay-in-place metal forms will not be allowed unless approval is given in writing by the Engineer with concurrence of the State Aid Bridge Engineer.

**S-804.03.15--Removal of Falsework, Forms, and Housing.** In the determination of the time for the removal of falsework, forms, and housing and the discontinuance of heating, consideration shall be given to the location and character of the structure, the weather and other conditions influencing the setting of the concrete, and the materials used in the mix. No forms or supports shall be removed prior to approval by the Engineer. During cold weather, removal of housing and the discontinuance of heating shall be in accordance with S-804.03.16.1.

Concrete in the last pour of a continuous superstructure shall have attained a compressive strength of 2,400 psi, as determined by cylinder tests, prior to striking any falsework. It is important that falsework be removed as evenly as possible to prevent excessive deflection stresses in the spans.

At the Contractor's option and with the approval of the Engineer, the time for removal of forms may be determined by cylinder tests, in which case the Contractor shall furnish facilities for testing the cylinders. The facilities shall include an approved concrete testing machine of sufficient capacity and calibrated by an acceptable commercial laboratory. Tests shall be conducted in the presence of the Engineer's representative to witness and record strengths obtained on each break or performed by a certified technician in an approved testing laboratory.

When form removal or placing of beams is not controlled by cylinder tests, Column A, exclusive of the days when the ambient temperature is below 40°F, herein shall apply as a guide for removal of forms and falsework. When cylinder tests are used, Column B shall be used. The cylinders shall be cured under conditions which are not more favorable than those existing for the portions of the structure which they represent.

If Type IP cement or Type I or II Portland cement plus fly ash is used, only Column B will be applicable.

	<u>Column A</u> <u>Minimum Cure</u>	<u>Column B</u> <u>Minimum psi</u>
Forms:		
Columns	24 Hours	1000
Side of Beams	24 Hours	1000
Walls not under pressure	24 Hours	1000
Floor Slabs, overhead	7 Days	2000
Floor Slabs, between beams	7 Days	2000
Slab Spans	14 Days	2400
Other Parts	24 Hours	1000

	<u>Column A</u> <u>Minimum Cure</u>	<u>Column B</u> <u>Minimum psi</u>
Centering:		
Under Beams	14 Days	2400
Under Bent Caps	7 Days	2000
Limitation for Placing Beams on:		
Pile Bents, pile under beam	3 Days	2000
Frame Bents, two or more columns	7 Days	2200
Frame Bents, single column	14 Days	2400

Methods of form removal likely to cause overstressing of the concrete shall not be used. Forms and supports shall be removed in a manner that will permit the concrete to uniformly and gradually take the stresses due to its own weight. Centers shall be gradually and uniformly lowered in a manner that will avoid injurious stresses in any part of the structure.

As soon as concrete for railings, ornamental work, parapets and vertical faces which require a rubbed finish has attained a safe strength, the forms shall be carefully removed without marring the surfaces and corners, the required finishing performed, and the required curing continued.

Prior to final inspection of the work, the Contractor shall remove all falsework, forms, excavated material or other material placed in the stream channel during construction. Falsework piles may be cut or broken off at least one foot below the mudline or ground line unless the plans specifically indicate that they are to be pulled and completely removed from the channel.

#### **S-S-804.03.16--Cold or Hot Weather Concreting.**

**S-804.03.16.1--Cold Weather Concreting.** In cold weather, the temperature of the concrete when delivered to the job site shall conform to the temperature limitations of "Temperature Limitations on Concrete when Delivered to Job Site" listed in Table 6 below.

When the Contractor proposes to place concrete during seasons when there is a probability of ambient temperatures lower than 40°F, the Contractor shall have available on the project the approved facilities necessary to enclose uncured concrete and to keep the temperature of the air inside the enclosure within the ranges and for the minimum periods specified herein.

When there are indications of temperatures of less than 40°F during the first four days after placement of the concrete, the concrete shall be protected from cold temperatures by maintaining a temperature between 50°F and 100°F for at least four days after placement and between 40°F and 100°F for at least three additional days. The Contractor shall use such heating equipment such as stoves, salamanders, or steam equipment as deemed necessary to protect the concrete. When dry heat is used, means of maintaining atmospheric moisture shall be provided.

One or more of the aggregates and/or mixing water may be heated. The aggregates may be heated by steam, dry heat, or by placing in the mixing water which has been heated. Frozen aggregates shall not be used. When either aggregates or water are heated above 100°F, the aggregates and water shall be combined first in the mixer before the cement is added to avoid flash set. Cement shall not be mixed with water or with a mixture of water and aggregate having a temperature greater than 100°F.

The use of salt or other chemical admixtures in lieu of heating will not be permitted.

Before placing concrete, all ice or frost shall be removed from the forms and reinforcement.

In the case of concrete placed directly on or in the ground, such as for footings or bottom slabs, a sufficient supply of straw, hay, grass, or other suitable blanketing material shall be provided to protect the work when the air temperature may be expected to drop below 35°F. The Contractor shall be responsible for the quality and strength of the concrete placed during cold weather, and all concrete injured by frost action shall be removed and replaced at no additional cost to the Project. The Engineer reserves the right to perform destructive or nondestructive testing for evaluation of damage caused by cold weather.

The Contractor shall assume all risk and added cost connected with the placing and protecting of concrete during cold weather. Permission given by the Engineer to place concrete during such time will in no way relieve the Contractor of responsibility for satisfactory results. Should it be determined at any time that the concrete placed under such conditions is unsatisfactory, it shall be removed and replaced with satisfactory concrete by the Contractor without extra compensation.



TABLE 6

**COLD WEATHER TEMPERATURE LIMITATIONS ON  
CONCRETE WHEN DELIVERED TO JOB SITE**

Ambient Temperature °F	Minimum Concrete Temperature °F	
	For sections with least dimension less than 12 inches	For sections with least dimensions 12 inches or greater
30 to 45	60	50
0 to 30	65	55
Below 0	70	60

**S-804.03.16.2--Hot Weather Concreting.** The manufacture, placement, and protection of concrete during hot weather requires special attention to insure that uniform slump ranges and satisfactory placement qualities are maintained, that surface cracking is held to a minimum, and that design strengths are produced.

**S-804.03.17--Curing Concrete.** Concrete surfaces shall be protected from premature drying by covering as soon as possible with a satisfactory curing material. When wetted burlap is used, it shall be not less than two thicknesses of Class 3 burlap or its equivalent, and the burlap shall be kept continuously and thoroughly wet. Careful attention shall be given to the proper curing and protection of concrete, and curing by the wetting method shall continue for a period of at least seven days after placing the concrete. If high-early-strength cement is used, this period may be reduced to four days.

Surfaces to have a Class 2 rubbed or sprayed finish and bridge deck surfaces when the atmospheric temperature is 90°F or above shall be cured only by wetting methods. The curing of concrete bridges with membrane curing will be permitted only under the conditions specified herein.

Surfaces on which curing is to be by liquid membrane shall be given the required surface finish prior to the application of curing compound. During the finishing period the concrete shall be protected by the water method of curing. Concrete surfaces cured by the liquid membrane method shall receive two applications of curing compound. The first application shall be applied immediately after the finishing is completed and accepted. Prior to applying the first application, the concrete shall be thoroughly wetted with water and the liquid membrane applied just as the surface film of water disappears. The second application shall be applied immediately after the first application has set.

The rate of application of curing compound will be as prescribed by the Engineer with a minimum spreading rate per application of one gallon per 200 square feet of concrete surface. The coating shall be protected against marring for at least 10 days after the application of the curing compound. The coating on bridge decks shall receive extra attention and may require additional protection as required by the Engineer. All membrane marred or otherwise disturbed shall be given an additional coating. Should the surface coating be subjected repeatedly to injury, the Engineer may require that the water curing method be applied at once.

When using curing compound, the compound should be thoroughly mixed within an hour before use. If the use of curing compound results in a streaked or blotched appearance, the method shall be stopped and water curing applied until the cause of defective appearance is corrected.

Other precautions to insure the development of strength shall be taken as directed.

Adequate tarpaulins of ample size shall be on the project and used as necessary to protect the work in case of rain or other emergencies.

Conditions governing the placement of concrete and the requirements for the placement, protection, and curing of concrete during cold or hot weather shall conform to the limitations, conditions, and requirements stipulated in S-804.03.16 as applicable.

**S-804.03.18--Expansion and Fixed Joints, Bearings, Anchor Bolts, Plates, Castings, Pipes, Drains, Conduits, Etc.** All joints shall be constructed according to details shown on the plans. The edges of the concrete at open or filled joints shall be chamfered or edged as indicated on the plans.

**S-804.03.18.1--Open Joints.** Open joints shall be placed in the locations shown on the plans and shall be constructed by the insertion and subsequent removal of a wood strip, metal plate, or other approved material. The insertion and removal of the template shall be accomplished without chipping or breaking the corners of the concrete. Reinforcement shall not extend across an open joint unless so specified on the plans.

**S-804.03.18.2--Filled Joints.** Poured expansion joints and joints to be sealed with premolded materials shall be constructed similar to open joints. When premolded types are specified, the filler shall be placed in correct position as the concrete on one side of the joint is placed. When the form is removed, the concrete on the other side shall be placed. Adequate water stops of metal, rubber, or plastic shall be carefully placed as shown on the plans.

**S-804.03.18.3--Premolded and Preformed Joint Seals.** When preformed elastomeric compressive joint seals are specified, the previously formed and cured open joint shall be thoroughly cleaned of all foreign matter, the required adhesive uniformly applied, and the seal installed in accordance with the recommendations of the manufacturer of the seal.

When premolded filler is used for the joints in the roadway slab, the tops shall be adequately sealed with poured joint filler in accordance with details on the plans. Premolded filler shall be permanently fastened to an adjacent concrete surface by appropriate use of copper wire, copper nails, or galvanized nails.

**S-804.03.18.4--Steel Joints.** The plates, angles, or other structural shapes shall be accurately shaped at the shop to conform to the section of the concrete floor. Fabrication and painting shall conform to the specifications covering those items. When called for on the plans or in the special provisions, the material shall be galvanized in lieu of painting. Care shall be taken to insure that the surface in the finished plane is true and free of warping. Positive methods shall be employed in placing the joints to keep them in correct position during the placing of the concrete. The opening at expansion joints shall be that designated on the plans at normal temperature, and care shall be taken to avoid impairment of the clearance in any manner.

**S-804.03.18.5--Water Stops.** Adequate water stops of metal, rubber, or plastic shall be placed as shown on the plans. Where movement at the joint is provided for, the water stops shall be of a type permitting movement without injury. They shall be spliced, welded, or soldered to form continuous watertight joints.

**S-804.03.18.6--Bearing Devices.** Bearing plates, rockers, and other bearing devices shall be constructed according to details shown on the plans. Unless otherwise specified or set in plastic concrete, they shall be set in grout to insure uniform bearing. Structural steel and painting shall conform to the requirements of S- 810 and S-814. When specified, the material shall be galvanized in lieu of painting. The rockers or other expansion bearing devices shall be set, considering the temperature at the time of erection, so that the required position of the device is provided.

At all points of bearing contact, concrete members shall be separated from underlying members by dimensioned bearing pads or by methods and/or materials specified on the plans.

When not otherwise specifically provided, contact areas between concrete super-structures and substructures shall be separated by three layers of No. 15, Type I, roofing felt.

**S-804.03.18.7--Friction Joints.** Metal friction joints shall consist of plates as indicated on the plans and shall be securely anchored in correct position. All sliding surfaces shall be thoroughly coated with an approved graphite grease. Movement shall not be impeded by the concrete in which the plates are embedded.

**S-804.03.18.8--Placing Anchor Bolts, Plates, Castings, Grillage, Conduits, Etc.** All anchor bolts, plates, castings, grillage, conduits, etc. indicated on the plans to be placed in or on the concrete shall be placed, set, or embedded as indicated or as directed. These items of the construction shall be set in portland cement mortar as referenced in S-714.11.5, except that anchor bolts may, as permitted by the Engineer, be built into the masonry, set in drilled holes, or placed as the concrete is being constructed by inserting encasing pipe or oiled wooden forms of sufficient size to allow for adjustment of the bolts. After removal of the pipe or forms, the space around the bolts shall be filled with portland cement mortar completely filling the holes. The bolt shall be set accurately and perpendicular to the plane of the seat.

Anchor bolts which are to be set in the masonry prior to the erection of the superstructure shall be carefully set to proper location and elevation with a template or by other suitable means.

When bed plates are set in mortar, no superstructure or other load shall be placed thereon until this mortar has been allowed to set for a period of at least 96 hours, subject to the restrictions for cold weather concreting in S-804.03.16.1. The mortar shall be kept well moistened during this period.

Weep hole drains shall be installed in abutments and retaining walls, and roadway drains or scuppers shall be installed in the roadway slabs in accordance with the details shown on the plans.

Where backfill is to be made at weep holes or openings in the structure, sand or stone chimneys or French drains shall be constructed as specified and shall extend through the portion of the backfill to be drained. Except as otherwise provided, the sand, stone, or slag used in this construction shall meet the requirements of S-704.04.

**S-804.03.19--Finishing Concrete Surfaces.**

**S-804.03.19.1--Classes of Finishes.** Surface finishes of exposed concrete surfaces shall be classified as follows:

- Class 1 - Ordinary Surface Finish
- Class 2 - Rubbed or Spray Finish
- Class 3 - Tooled Finish
- Class 4 - Sand-Blast Finish
- Class 5 - Wirebrush or Scrubbed Finish
- Class 6 - Floated Surface Finish

**S-804.03.19.2--Class 1, Ordinary Surface Finish.** Immediately following the removal of forms, all fins and irregular projections shall be removed from all surfaces except from those which are not to be exposed or not to be waterproofed. On all surfaces, the cavities produced by form ties and all other holes, honeycomb spots, broken corners or edges, and other defects shall be thoroughly cleaned, and after having been kept saturated with water for at least three hours shall be carefully pointed and trued with a mortar of cement and fine aggregate mixed in the proportions used in the class of the concrete being finished. Mortar used in pointing shall be not more than one hour old. The mortar patches shall be cured as specified under S-804.03.17. All construction and expansion joints shall be left carefully tooled and free of mortar and concrete. The joint filler shall be left exposed for its full length with clean and true edges.

The resulting surfaces shall be true and uniform. All surfaces which cannot be repaired to the satisfaction of the Engineer shall be given a Class 2 rubbed finish.

**S-804.03.19.3--Class 2, Rubbed or Spray Finish.**

**S-804.03.19.3.1--Rubbed Finish.** After removal of forms, the Class 1 finish shall be completed and the rubbing of concrete shall be started as soon as its condition will permit. Immediately before starting this work, the concrete shall be kept thoroughly saturated with water for at least three hours. Surfaces shall be rubbed with a medium course Carborundum stone using a small amount of mortar on its face. The mortar shall be composed of cement and sand mixed in the proportions used in the concrete being finished. Rubbing shall be continued until all form marks, projections, and irregularities have been removed, all voids are filled, and a uniform surface has been obtained. The paste produced by this rubbing shall be left in place at this time.

After all concrete above the surface being treated has been cast, the final finish shall be obtained by rubbing with a fine Carborundum stone and water. This rubbing shall continue until the entire surface is of a smooth texture and uniform color.

After the final rubbing is completed and the surface has dried, it shall be rubbed with burlap to remove loose powder and objectionable marks.

**S-804.03.19.3.2--Spray Finish.** Prior to the spray finish, the concrete shall be given a Class 1 finish in accordance with S-804.03.19.2, supplemented if necessary with a grout meeting the requirements of S--714.11 with fine aggregate modified to require 100 percent passing the No. 16 Sieve.

Grout shall be applied with burlap pads or float sponges, and as soon as the grout has dried the surface shall be brushed to remove all loose grout and the surface left smooth and free of air holes. Surfaces to be sprayed shall be free of efflorescence, flaking coatings, dirt, oil, and other foreign substances. Prior to application of the spray finish, the surfaces shall be free of moisture, as determined by sight and touch, and in a condition consistent with the manufacturer's published recommendations.

The spray finish material shall meet the requirements of S-714.12 and shall be listed on MDOT's Approved Sources of Materials. The spray finish shall be applied with heavy duty spray equipment capable of maintaining a constant pressure as necessary for proper application. The material shall be applied as recommended by the manufacturer except the rate of application shall not be less than one gallon per 50 square feet of surface area without prior written approval of the Engineer.

The completed finish shall be tightly bonded to the structure and present a uniform appearance and texture equal to or better than a rubbed finish. If necessary, additional coats shall be sprayed to produce the desired surface texture and uniformity. Upon failure to adhere positively to the structure without chipping or cracking or to attain the desired surface appearance, the coatings shall be completely removed and the surface given a rubbed finish in accordance with S-804.03.19.3.1, or other approved methods shall be used to obtain the desired surface finish to the satisfaction of the Engineer without additional cost to the Project.

**S-804.03.19.4--Classes 3, 4, and 5 Finishes.** If required, specifications for these finishes will be contained in the special provisions.

**S-804.03.19.5--Class 6, Floated Surface Finish.** After the concrete has been deposited in place, it shall be consolidated and the surface shall be struck off by means of a strike board and floated with a wooden or cork float. An edging tool shall be used on edges and expansion joints. The surface shall not vary more than 1/8 inch under a 10-foot straightedge. The surface shall have a granular or matte texture which will not be slick when wet.

**S-804.03.19.6--Required Finishes for Various Surfaces.**

**S-804.03.19.6.1--General.** Unless otherwise specified, the top surface of sidewalks, the top horizontal surfaces of footings, and top slabs of box bridges, box culverts, or other structures shall be given a Class 6 finish. All formed concrete surfaces shall be given a Class 1 finish, except on surfaces which are completely enclosed, such as the inside surfaces of cells of box girders, the removal of fins and form marks and the rubbing of mortared surfaces to a uniform color will not be required.

In reference to finishing, exposed surfaces are surfaces or faces which may be seen after all backfill has been placed. Exposed surfaces requiring a Class 2 finish shall be finished at least one foot below the ground line or the low water elevation, whichever is higher.

The Class 2 finish shall be made upon a Class 1 finish. After the removal of forms the Class 1 finish shall be completed and the rubbing of concrete shall be started as soon as the condition of the concrete will permit.

Bridge floors shall be finished in accordance with S-804.03.19.7.

**S-804.03.19.6.2--Finishing Formed Concrete Surfaces of Box Bridges, Box Culverts, Pipe Headwalls, and Minor Structures.** The exposed surfaces of wing walls and parapets of box bridges and box culverts to be used as vehicular or pedestrian underpasses shall be given a Class 2 finish. Exposed surfaces of other box culverts or box bridges, pipe culvert headwalls, and other minor structures shall be given a Class 1 finish unless otherwise indicated on the plans.

The exposed surfaces of retaining walls including copings and parapets shall receive a Class 2 finish.

**S-804.03.19.6.3--Finishing Formed Concrete Surface of Bridges.** All formed concrete bridge surfaces which are exposed shall have a Class 1 or 2 finish as set forth herein unless designated otherwise on the plans.

Bridges with designated surfaces for Class 2 finish are classified as follows:

- Group A - Bridges over highways, roads and streets.
- Group B - Bridges over waterways and railroads.
- Group BB - Twin or adjacent bridges of Group B category.

When a Group B or BB bridge also spans a highway, road or street, exposed concrete surfaces shall be finished in accordance with Group A requirements.

- (A) Superstructures. Concrete surfaces to be given a Class 2 finish shall be the exposed surfaces of wings and rails and other exposed surfaces indicated by a double line in Figures 804-1, 804-2, and 804-3.

When a Group B or BB bridge also spans a highway, road or street, the superstructure of spans over and extending one span in each direction beyond the lower level highway, road or street shall be given a Class 2 finish as shown for Group A.

- (B) Substructures. Concrete surfaces to be given a Class 2 finish are as follows:

- Group A. Exposed surfaces of abutments, end bents, end bent posts, wing walls, railing, retaining walls, parapets, copings, piers, columns, piles, caps, struts or walls between columns or piles, encasement of steel piles, arch rings and spandrel walls.
- Group B and BB. Exposed surfaces of abutments, wing walls, end bent posts, railing, retaining walls, parapets and copings.

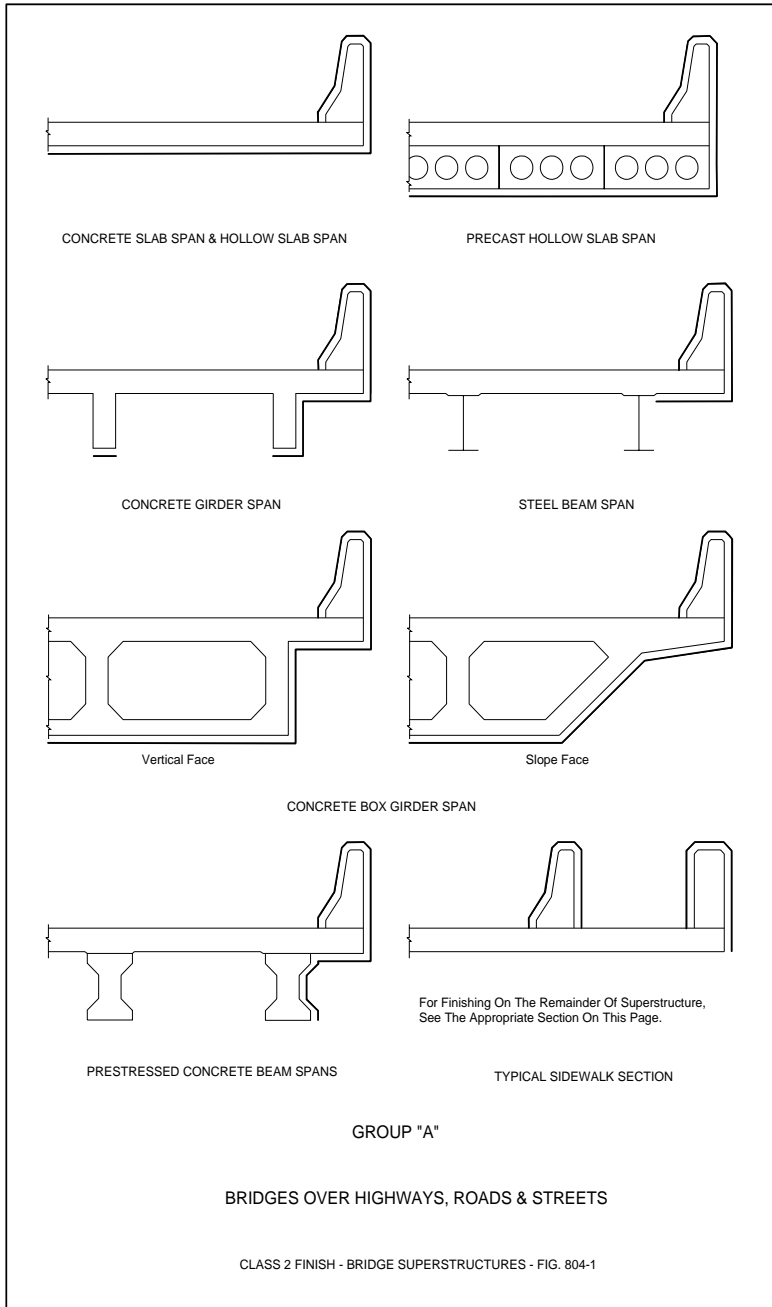



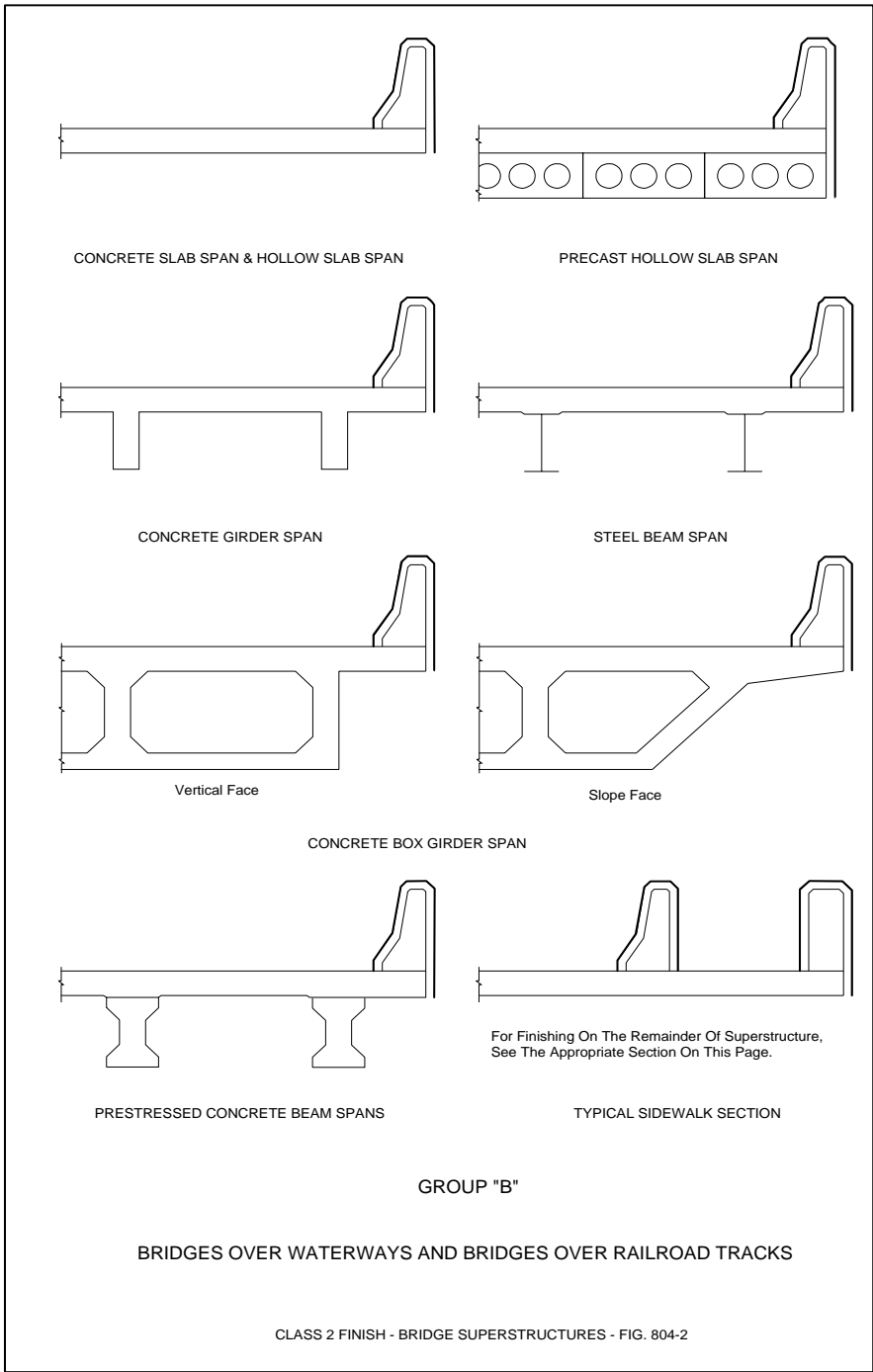

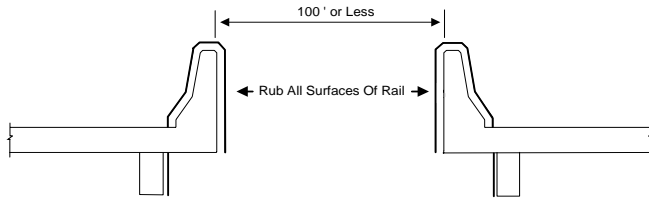

GROUP "B B" - ADJACENT BRIDGES

GROUP "B B"

TWIN or DUAL BRIDGES

CLASS 2 FINISH - BRIDGE SUPERSTRUCTURES - FIG. 804-3

**S-804.03.19.7--Finishing Bridge Floors.**

**S-804.03.19.7.1--General.** Concrete bridge decks shall be struck off and finished by the method(s) designated on the plans.

In the event a method is not designated, the Contractor may use either the longitudinal or transverse method subject to the requirements contained in these specifications.

Except when indicated otherwise on the plans, the final surface texture of the bridge floor shall be either a drag, belt, or broom finish. The surface texture specified and surface requirements shall be in accordance with the following:

**Final Strike-Off, Consolidation and Finishing.**

**Sequence.** The sequence of operations shall be the strike-off and consolidation, floating and removal of laitance, straight-edging, and final surface finish. If a finish is not designated, the finish shall be a belt finish.

Concrete, as soon as placed, shall be struck off and screeded. An approved portable screed shall be used. A second screed shall be provided for striking off the bottom layer of concrete if reinforcement is used and the pavement is placed in two layers.

The screed for the surface shall be at least two feet longer than the maximum width of the slab to be struck off. It shall be of approved design, sufficiently rigid to retain its shape, and be constructed of metal or of other suitable material shod with metal.

Consolidation shall be attained by the use of a suitable vibrator or other approved equipment.

In operation the screed shall be moved forward with a combined longitudinal and transverse shearing motion, and manipulated so that neither end is raised from the side forms during the striking off process. If necessary, this shall be repeated until the surface is of uniform texture, true to grade and cross section, and free from porous areas.

In general, the addition of superficial water to the surface of the concrete to assist in finishing operations will not be permitted. If the application of water to the surface is permitted, it shall be applied as a fog spray by means of approved spray equipment.

**Finishing at Joints.** The concrete adjacent to joints shall be compacted or firmly placed without voids or segregation against the joint material, and also under and around all load transfer devices, joint assembly units, and other features designed to extend into the pavement. Concrete adjacent to joints shall be mechanically vibrated.

After the concrete has been placed and vibrated adjacent to the joints, the finishing machine shall be brought forward, operating in a manner to avoid damage or misalignment of joints. If uninterrupted operation of the finishing machine, to, over, and beyond the joints causes segregation of concrete, damage to, or misalignment of the joints, the finishing machine shall be stopped when the front screed is approximately eight inches from the joint. Segregated concrete shall be removed from in front of and off the joint, and the front screed shall be lifted and set directly on top of the joint and the forward motion of the finishing machine resumed. When the second screed is close enough to permit the excess mortar in front of it to flow over the joint, it shall be lifted and carried over the joint. Thereafter, the finishing machine may be run over the joint without lifting the screeds, provided there is no segregated concrete immediately between the joint and the screed or on top of the joint.

**Machine Finishing.** Unless otherwise specified, full width vibration shall be performed. If uniform and satisfactory density of the concrete is not obtained by the vibratory method at joints, along forms, at structures, and throughout the pavement, the Contractor shall furnish equipment and methods which will produce pavement conforming to the specifications.

**Hand Finishing.** Unless otherwise specified, hand finishing methods, other than the hand floating method described below, will not be permitted except under the following conditions:

In the event of breakdown of the mechanical equipment, hand methods may be used to finish the concrete already deposited on the grade when the breakdown occurs.

Narrow widths or areas where operation of mechanical equipment is impractical may be finished by hand methods.

**Floating.** After the concrete has been struck off and consolidated, it shall be further smoothed and trued by means of a longitudinal float, using one of the following methods as specified:

- (a) **Hand Method.** The hand-operated longitudinal float shall be at least 12 feet long and six inches wide, properly stiffened to prevent flexibility and warping. The longitudinal float, operated from foot bridges spanning but not touching the concrete, shall be worked with a sawing motion while held in a floating position parallel to the road centerline, and passing gradually from one side of the pavement to the other. Movement ahead along the centerline of the pavement shall be in successive advances of not more than one-half the length of the float. Excess water and soupy material shall be wasted over the sides on each pass.

- (b) **Mechanical Method.** The mechanical longitudinal float shall be of a design approved by the Engineer, and shall be in good working condition. The float shall be accurately adjusted to the required crown, and coordinated with the adjustments of the transverse finishing machine so that a small amount of mortar is carried ahead of the float at all times. The float shall pass over each area of pavement at least two times, but excessive operation over a given area will not be permitted. Excess water and soupy material shall be wasted over the sides on each pass.

As an alternative to the mechanical method, the Contractor may use a machine composed of a cutting and smoothing float, or floats, suspended from and guided by a rigid frame. The frame shall be carried by four or more visible wheels riding on and constantly in contact with the side forms, or track line of a slip-form paver.

If necessary, following one of the preceding methods of floating, long-handled floats having blades at least five feet long and six inches wide may be used to smooth and fill in open-textured areas in the pavement. Long-handled floats shall not be used to float the entire surface of the pavement in lieu of, or to supplement, one of the preceding methods of floating. When strike-off and consolidation are done by the hand method and the crown of the pavement will not permit the use of the longitudinal float, the surface shall be floated transversely by means of the long-handled float. Care shall be taken not to work the crown out of the pavement during the operation. After floating, excess water and laitance shall be removed from the surface of the pavement by a straightedge 10 feet or more in length. Successive drags shall be lapped one-half the length of the blade.

**Straight-Edge Testing and Surface Correction.** After the floating has been completed and while the concrete is still plastic, the surface of the concrete shall be tested with a 10 foot straightedge. For this purpose the Contractor shall furnish and use an accurate 10-foot straightedge swung from handles three feet longer than one-half the width of the slab. The straightedge shall be held in contact with the surface in successive positions parallel to the road centerline and the whole area gone over from one side of the slab to the other as necessary. Advance along the road shall be in successive stages of not more than one-half the length of the straightedge. All depressions found shall be immediately filled with freshly mixed concrete, struck off, consolidated, and refinished. High areas shall be cut down and refinished. Special attention shall be given to assure that the surface across joints is smooth and to grade. Straightedge testing and surface corrections shall continue until the entire surface is found to be free from observable departures from the straightedge, and the slab conforms to the required grade and cross section.

**Final Finish.** The surface finish of the concrete shall be that designated on the plans and in the bid schedule of the contract. If a finish is not designated, the finish shall be a belt finish.

**Drag Finish.** This finish shall consist of a uniform surface of gritty texture produced by dragging a seamless strip of damp burlap or cotton fabric longitudinally along the full width of pavement. For pavement 16 feet or more in width, the drag shall be mounted on a bridge which travels on the forms or track line. The dimensions of the drag shall be such that a strip of burlap or fabric at least three feet wide is in contact with the full width of pavement surface while the drag is used. The drag shall consist of at least two layers of burlap with the bottom layer approximately six inches wider than the upper layer. The drag shall be maintained in a condition that will produce a surface of uniform appearance with corrugations approximately one-sixteenth inch in depth. Drags shall be maintained clean and free from encrusted mortar. Drags that cannot be cleaned shall be discarded and new drags substituted.

**Broom Finish.** A broom finish shall be applied when the water sheen has practically disappeared. The broom shall be drawn from the center to the edge of the pavement with adjacent strokes slightly overlapping. The brooming operations shall produce corrugations in the surface that are uniform in appearance and not more than 1/16 inch in depth. Brooming shall be completed before the concrete has set to a degree that the surface will be torn or unduly roughened by the operation. The finished surface shall be free from rough and porous areas, irregularities, and depressions. Brooms shall be of the quality, size, and construction and operated so as to produce a surface finish meeting the approval of the Engineer. Subject to satisfactory results being obtained and approval of the Engineer, the Contractor will be permitted to substitute mechanical brooming in lieu of manual brooming as herein described.

**Belt Finish.** When straight-edging is complete and the water sheen has practically disappeared and just before the concrete becomes nonplastic, the surface shall be belted with a two-ply canvas belt eight inches wide and at least three feet longer than the pavement width. Hand belts shall have suitable handles to permit controlled, uniform manipulation. The belt shall be operated with short strokes transverse to the road centerline and with a rapid advance parallel to the center line. Subject to satisfactory results being obtained and approval of the Engineer, the Contractor will be permitted to substitute mechanical belting in lieu of manual belting as herein described.

**Transverse Tine Finish.** The surface shall first be given a drag finish. After completion of the drag finish, the pavement shall be given an additional texture by transverse tining.

The final surface texture shall be produced with a metal tine finishing device. The texturing device shall be so constructed and operated as to produce uniform parallel grooves perpendicular to the centerline of the pavement 1/2 inch on centers and having a depth of 1/8 inch, plus or minus 1/32 inch.

The metal tine device shall be operated by approved mechanical means when texturing main roadway pavement lanes. Manual methods may be used for texturing small irregular areas inaccessible to the texturing machine.

The depth of the finished grooves will be determined by the use of a standard commercial tire tread depth measuring gage with 1/32 inch graduations that can be easily and accurately read, a brass wire brush, and a steel straightedge approximately 1/4 inch x 1 inch x 12 inches. The Contractor shall furnish this equipment for use by and subject to the approval of the Engineer.

If for any reason the concrete hardens to the extent that the tining equipment does not provide grooving in accordance with these requirements, or if rainfall damages the finish and the Engineer permits the concrete to remain in place, the Contractor shall use other approved devices such as saws to construct the grooves substantially in accordance with the requirements specified herein.

**Transverse Grooved Finish.** After the concrete has cured for a minimum of seven (7) days, areas to be transverse grooved shall be grooved with a sawing device. Grooves shall be perpendicular to the centerline of the roadway and extend as close as possible to the edge but in no case more than two (2) feet from the edge, gutter line, etc. The tolerance for the width of the groove is +1/16" to -0" and the tolerance for the depth and spacing of the grooves is  $\pm 1/16$ ".

**Edging at Forms and Joints.** After the final finish, but before the concrete has taken its initial set, the pavement along each side of each slab, and on each side of transverse expansion joints, formed joints, transverse construction joints, and emergency construction joints shall be worked with an approved tool and rounded to the radius required by the plans. A well-defined and continuous radius shall be produced and a smooth, dense, mortar finish obtained. The surface of the slab shall not be unduly disturbed by tilting of the tool during use.

At all joints, all tool marks appearing on the slab adjacent to the joints shall be eliminated by brooming the surface. In doing this, the rounding of the corner of the slab shall not be disturbed. All concrete on top of the joint filler shall be completely removed.

All joints shall be tested with a straightedge before the concrete has set, and correction made if one side of the joint is higher than the other, or if they are higher or lower than the adjacent slabs.

**S-804.03.19.7.2--Longitudinal Method.** The longitudinal method requires that the strike-off screed be supported on accurately graded and supported bulkheads or templates placed across the full width at the end(s) of the pour. Before the concrete is placed, approved fixed templates or wooden bulkheads of not less than 1 1/4-inch lumber shall be placed perpendicular to the centerline of the roadway, or in the case of skew bridges at the angle of skew. The upper surface of the template or bulkheads shall be accurately set to conform to the required grade and crown.

Special attention shall be given to the gutter lines where the strike-off screed cannot reach. The gutters shall be finished by hand and tested with the straight edge. Floor drains shall be set lower than the finished gutter line and finished over. After initial set, the concrete shall be dished out and finished around the drains to form an outlet.

After the concrete has been deposited and rough graded, it shall be struck off by means of a strike-off screed resting on the bulkheads or fixed templates. The strike-off screed shall be of a type satisfactory to the Engineer and shall have sufficient strength to retain its shape under all working conditions. The final surface shall comply with the applicable requirements above, and unless otherwise specified in the contract, the final finish under this method shall be the belt finish.

In general, the overall strike-off screed should be trussed, with bracing heavy enough to support the weight of a man without deflecting, and should be adjustable for camber and correction of sag.

The strike-off screed will ride on the bulkheads or fixed templates at the ends of the section being finished. Care shall be taken to see that the bulkhead or fixed template elevations are accurately set since the entire span surface will be controlled by them. The manipulation of the screed shall be such that neither end is raised from the bulkheads or templates during the process.

The concrete shall be struck off by beginning at one curb and proceeding entirely across the span. A slight excess of concrete shall be kept in front of the cutting edge at all times. This operation shall be repeated at least three times. In each case, the strike-off screed shall be picked up and carried back to the point of beginning. No backward strokes will be allowed. The strike-off screed shall be moved along the bulkheads or fixed templates with a combined longitudinal and transverse motion. This operation may be manual or mechanical. Standing or walking in the fresh concrete ahead of the strike-off screed will not be permitted.

**S-804.03.19.7.3--Transverse Method.** The transverse method requires that the screeding equipment be supported on accurately graded and supported rails placed beyond the gutter lines and parallel with the centerline of the bridge.

The machine shall be so constructed and operated as to produce a bridge floor of uniform density with minimum manipulation of the fresh concrete and achieved in the shortest possible time. Manual transverse methods of screeding will not be permitted.



The finishing machine shall be supported on vertically adjustable rails set a sufficient distance from the gutter line to allow free movement of the screed from gutter line to gutter line. Satisfactory means of load distribution with minimum rail deflection shall be provided. The screed rails for a deck pour shall be completely in place for the full length of the pour and shall be firmly secured prior to placing concrete. The screed rails shall be adjusted as necessary to compensate for settlement and deflection occurring during the screeding operations. Supports for the screed rail shall be located directly over slab overhang support brackets as referenced in S-804.03.14.1.

At least one dry run shall be made the length of each pour with a "tell-tail" device attached to the screed carriage to assure the specified clearance to the reinforcing steel.

The screed shall be equipped with a metal cutting edge or other approved mechanical means for accurately fine grading the plastic concrete to the required grade and surface smoothness and shall be supported by a bridging structure sufficiently rigid and heavy to perform operations satisfactorily on concrete of minimum slump without vibration, distortion, and wrecking of forms. The screed shall be mechanically actuated to deliver the screeding action and for travel in a longitudinal direction at a uniform rate along the bridge floor.

The screed shall complete sufficient passes to strike off all of the excess concrete with ample mortar along the entire leading edge to assure filling of low spots. Care shall be taken to remove all objectionable material from the gutters where final hand finishing will be required.

The selection of the transverse method may require the Contractor to furnish bridge deck concrete which contains an approved water-reducing set retarding admixture in the quantities approved by the Engineer at no additional cost to the Project. See S-713.02 for more information.

Other finishing requirements shall be in accordance with the general requirements in S-804.03.19.7.1 and as specified on the plans.

**S-804.03.19.7.4-Acceptance Procedure for Bridge Deck Smoothness.** Bridges must meet a 1/8 inch in 10-foot straightedge requirement in longitudinal and transverse directions.

**S-804.03.19.7.4.1--Grinding Bridge Decks.**

**S-804.03.19.7.4.1.1--Equipment.** The grinding equipment shall be a power driven, self-propelled machine that is specifically designed to smooth and texture Portland cement concrete pavement with diamond blades. The effective wheel base of the machine shall not be less than 12.0 feet. It shall have a set of pivoting tandem bogey wheels at the front of the machine and the rear wheels shall be arranged to travel in the track of the fresh cut pavement. The center of the grinding head shall be no further than 3.0 feet forward from the center of the back wheels.

The equipment shall be of a size that will cut or plane at least 3.0 feet wide. It shall also be of a shape and dimension that does not encroach on traffic movement outside of the work area. The equipment shall be capable of grinding the surface without causing spalls at cracks, joints, or other locations.

**S-804.03.19.7.4.1.2--Grinding.** The grinding areas will be determined by the Contractor, based on the 10 foot straightedge test, and approved by the Engineer. The Contractor shall develop and submit to the Engineer for approval a Grinding Plan. The Contractor shall allow up to 45 days for the Engineer to review the Plan prior to starting any grinding operations. This plan shall include as a minimum:

- (1) Name of the project superintendent in responsible charge of the grinding operation.
- (2) List and description of all equipment to be used.
- (3) Maximum depth of each pass allowed by the grinding equipment.
- (4) Maximum width of each pass allowed by the grinding equipment.
- (5) Details of a sequence of the grinding operation.
- (6) Data showing reinforcing steel clearance in all areas to be ground.
- (7) A detailed drawing of the deck showing areas to be ground with station numbers and grinding depths clearly indicated.
- (8) A description of grinding in areas where drains are in conflict with grind areas.
- (9) Details of any changes in deck drainage, anticipated ponding, etc.

The Engineer will evaluate the grinding plan for conformance with the plans and specifications, after which the Engineer will notify the Contractor of any additional information required and/or changes that may be needed. Any part of the plan that is unacceptable will be rejected and the Contractor shall submit changes for reevaluation. All approvals given by the Engineer shall be subject to trial and satisfactory performance in the field, and shall not relieve the Contractor of the responsibility to satisfactorily complete the work.

The construction operation shall be scheduled and proceed in a manner that produces a uniform finished surface. Grinding will be accomplished in a manner that eliminates joint or crack faults while providing positive lateral drainage by maintaining a constant cross-slope between grinding extremities in each lane. Auxiliary or ramp lane grinding shall transition as required from the mainline edge to provide positive drainage and acceptable riding surface.

The operation shall result in a finished surface that conforms as close as possible to the typical cross-section and the requirements specified in S-804.03.19.7.4.1.3.

The Contractor shall establish positive means for removal of grinding residue. Residue shall not be permitted to flow across lanes used by public traffic or into gutters or drainage facilities.

**S-804.03.19.7.4.1.3--Final Surface Finish.** The grinding process shall produce a finish surface that is as close as possible to grade and uniform in appearance with a longitudinal line type texture. The line type texture shall contain parallel longitudinal corrugations that present a narrow ridge corduroy type appearance. The peaks of the ridges shall be approximately 1/16 inch higher than the bottoms of the grooves with approximately 53 to 57 evenly spaced grooves per foot. Grinding chip thickness shall be a minimum of 0.080 inches thick.

The finished bridge decks and bridge end slabs shall be retested for smoothness as per S-804.03.19.7.4.

**S-804.03.19.8--Finishing Horizontal Surfaces of Footings or Top Slabs of Box Bridges, Culverts, or Other Structures.** The finishing of horizontal surfaces of footing or top slabs of box bridges, culverts, or other structures shall be achieved by placing an excess of material in the form and removing or striking off the excess with a template, forcing the coarse aggregate below the mortar surface. After the concrete has been struck off the surface shall be given a Class 6 finish.

**S-804.03.19.9--Finishing Exposed Surfaces of Sidewalks.** After the concrete has been deposited in place it shall be consolidated and the exposed surface shall be given a Class 6 finish. An edging tool of the required radius shall be used on all edges and at all expansion joints. The surface shall have a granular texture which will not be slick when wet.

Sidewalk surfaces shall be laid out in blocks with an approved grooving tool as shown on the plans or as directed.

**S-804.03.20--Opening Bridges.**

**S-804.03.20.1--Public Traffic.** Unless otherwise specified, concrete bridge floors shall be closed to public highway traffic for a period of at least 21 days after placing concrete.

**S-804.03.20.2--Construction Traffic.** Unless otherwise specified, concrete bridge floors shall be closed to construction traffic for a period of seven days after placing concrete and the minimum required compressive strength for the concrete placed is obtained.

**S-804.03.21--Final Cleanup.** Upon completion of the work all equipment, surplus materials, forms, and waste material shall be removed, the bridge cleaned, and the site of the work given a final cleanup.

**S-804.03.22--Prestressed Concrete Bridge Members.**

**S-804.03.22.1--General.** All installations and plants for the manufacture of prestressed bridge members shall be PCI (Prestressed Concrete Institute) Certified. Bridge members manufactured in plants or installations not so approved will not be accepted for use in the work. The Contractor or other manufacturer shall employ a technician skilled in the adopted system of prestressing to supervise the manufacturing operations. This technician shall be certified according to the guidelines of this specification. The Contractor shall develop and implement a Quality Control Program as per Division I of PCI Quality Control Manual, 4th Edition. The Quality Control Program shall be submitted to the MDOT District Materials Engineer for approval.

**S-804.03.22.2--Stressing Requirements.** The jacks for stressing shall be equipped with accurate calibrated gages for registering the jacking pressure. Means shall be provided for measuring elongation of strands to at least the nearest 1/16 inch.

Prior to beginning work, the Contractor or manufacturer shall have all jacks to be used, together with their gages, calibrated by an approved laboratory. All jacks and gages shall have an accuracy of reading within two percent. The testing agency shall furnish the Engineer a statement certifying that the jacks and gages meet this requirement. During the progress of the work, if a gage appears to be giving erratic results or if the gage pressure and elongations indicate materially differing stresses, recalibration will be required.

Calibration of jacks and gages shall be repeated at intervals deemed necessary by the Engineer. These intervals for calibration shall not exceed one year.

Shop drawings of non-standard prestressed beams, including an erection plan, shall be submitted in duplicate to the Engineer for approval, with concurrence of the State Aid Bridge Engineer, prior to manufacture of members.

**S-804.03.22.2.1--Methods.** Plans for the particular bridge members will show prestressing by one of the following methods:

(A) Pretensioning. The prestressing strands are stressed initially. After the concrete is placed, cured, and has attained the compressive strength shown on the plans, the stress is transferred to the member. The method used for pretensions shall be in accordance to Division V of PCI Quality Control Manual, 4th Edition.

(B) Posttensioning. The posttensioning tendons are installed in voids or ducts and are stressed and anchored after development of the compressive strength specified on the plans. The voids or ducts are then pressure grouted.

(C) Combined Method. Part of the reinforcing is pretensioned and part posttensioned. Under this method all applicable requirements for the two methods specified shall apply to the respective stressing elements being used.

**S-804.03.22.2.2--Alternate Details for Prestressed Members.** In the event that the Contractor/ Manufacturer desires to use materials or methods that differ in any respect from those shown on the plans or described in these specifications, the Contractor shall submit for approval full plan details on acceptable tracings suitable for reproduction and specifications which shall become the property of the Engineer. In order for alternate materials and/or methods to be considered, they will be required to comply fully with the following:

- A. Provisions equal to those stipulated in these specifications.
- B. Current AASHTO Specifications.
- C. Recommendations of materials manufacturer.
- D. Camber tolerance of beams and spans shown on plans.

Note: Alternate materials and methods will not be authorized on Federal-Aid Projects.

The Engineer shall be the sole judge as to the adequacy and propriety of any variation of materials or methods.

**S-804.03.22.2.3--Stressing Procedure.**

- (A) General. Stressing shall be performed by suitable jacks working against unyielding anchorages and capable of maintaining the required stress for an indefinite period without movement or yielding. Strands may be stressed singularly or in a group.

The tension to be applied to each strand shall be as shown on the plans. The tension shall be measured by both jacking gages and elongations in the strands and the result shall check within close limits.

It is anticipated that there will possibly be a difference in indicated tension between jack pressure and elongation of about five (5) percent. In this event, the discrepancy shall be placed on the side of slight overstress rather than understress.

In the event of an apparent discrepancy between gage pressure and elongation of as much as five (5) percent, the entire operation shall be carefully checked, and the source of error determined before proceeding further.

Elongation is to be measured after the strands have been suitably anchored, and all possible slippage at the anchorages has been eliminated.

In all stressing operations, the stressing force shall be kept as nearly symmetrical about the vertical axis of the member as practicable.

- (B) Pretensioning. All strands to be prestressed shall be brought to a uniform initial tension prior to being given their full pretensioning. This uniform initial tension of approximately 1000 to 2000 pounds shall be measured by suitable means such as a dynamometer so that its value can be used as a check against elongation computed and measured.

After the initial tensioning, the strand or group shall be stressed until the required elongation and jacking pressure is within the limits specified.

When the strands are stressed in accordance with the plan requirements and these specifications and all other reinforcing is in place, the concrete shall be placed in the prepared forms.

Strand stress shall be maintained until the concrete between anchorages has attained the required compressive strength as determined by cylinder tests, after which the strands shall be cut off flush with the ends of column members, and cut as shown on the plans for beams, girders, etc. Strands shall be cut or released in such a manner that eccentricity of prestress will be kept to a minimum and no damage to the member will result. The strand cutting pattern shall be as shown on the plans or as approved by the State Aid Bridge Engineer.

- (C) Posttensioning. For all posttensioning tendons/bars the anchor plates shall set exactly normal in all directions to the axis of the tendon/bar. Parallel wire anchorage cones shall be recessed within the beams. Tensioning shall not take place until the concrete has reached the compressive strength shown on the plans.

Elongation and jacking pressures shall make appropriate allowance for all possible slippage or relaxation of the anchorage. Posttensioning tendons/bars shall be stressed in the order and manner shown on the plans.

The units shall be tensioned until the required elongations and jacking pressures are attained and reconciled within the limits specified in S-804.03.22.2.3(A) with such overstresses as approved by the Engineer for anchorage relaxation.

Independent references shall be established adjacent to each anchorage to indicate any yielding or slippage that may occur between the time of initial stressing and final release of the strands.

Straight tendons/bars may be tensioned from one end. Unless otherwise specified, curved tendons shall be stressed by jacking from both ends of the tendons.

- (D) Combined Method. In the event that girders are manufactured with part of the reinforcement pretensioned and part posttensioned, the applicable portions of the requirements listed herein shall apply to each type.

**S-804.03.22.3--Manufacture.**

**S-804.03.22.3.1--Forms.** The forms used for prestressed bridge members shall meet the requirements of Division II of the PCI Quality Control Manual, 4th Edition.

**S-804.03.22.3.2--Placing and Fastening Steel.** Placing and fastening of all steel used for prestressed bridge members shall meet the requirements of Division V of the PCI Quality Control Manual, 4th Edition.

**S-804.03.22.3.3--Holes for Prestressing Tendons/Bars.** Holes provided in girders for prestressing tendons/bars shall be formed by means of inflatable rubber tubing, flexible metal conduit, metal tubing, or other approved means.

**S-804.03.22.4--Placing and Curing Concrete.**

**S-804.03.22.4.1--Placing.** The placing of concrete shall meet the applicable requirements of Division III of PCI Quality Control Manual, 4th Edition.

**S-804.03.22.4.2--Curing.** Initial and accelerated curing of all members shall meet the applicable requirements of Division IV of PCI Quality Control Manual, 4th Edition except for the following listed requirements.

The source of heat for accelerated cure shall be steam. Calibrated thermocouples shall be implanted into the concrete members to monitor areas expected to have maximum and minimum heat. Curing methods and procedures listed in the prestress producer's PCI Quality System Manual shall be approved by MDOT before their implementation.

**S-804.03.22.4.3--Removal of Side Forms.** Side forms may be removed after the concrete has attained sufficient strength to maintain a true section. In order to obtain "sufficient strength", it may be necessary to cure members for 12 hours or more as prescribed in S-804.03.22.4.2, or to attain a minimum compressive strength of 1,000 psi.

If high-early-strength concrete is obtained by use of low slump (0 to 1.5-inch) concrete, vacuum process, or other approved methods, side forms may be removed earlier; however, approval of the methods and revision from normal schedules will be made only after inspections by the MDOT District and MDOT Central Laboratories have determined that satisfactory results will be attained by the methods and schedules proposed.

**S-804.03.22.4.4--Grouting.** The holes through posttensioned members in which the tendons are installed shall be equipped with approved grouting vents. All prestressing tendons to be bonded shall be free of dirt, loose rust, grease, or other deleterious substances. Before grouting, the ducts shall be free of water, dirt, and other foreign substances. The ducts shall be blown out with compressed air until no water comes through the ducts. For long members with draped tendons an open tap at low points may be necessary. After completion of stressing, the annular space between sides of tendon and sides of hole shall be grouted as set in the following paragraphs.

With the grouting vent open at one end of the core hole, grout shall be applied continuously under moderate pressure at the other end until all entrapped air is forced out through the open grout vent, as evidenced by a steady stream of grout at the vent. Whereupon, the open vent shall be closed under pressure. The grouting pressure shall be gradually increased to a refusal of at least 75 psi and held at this pressure for approximately 10 seconds, and the vent shall then be closed under this pressure.

Portland cement grout shall consist of a mixture of:

- 1 part Type 1 Portland cement
- 1/4 part fly ash
- 3/4 part washed sand \*
- 4 to 6 gallons of water per bag of cement.

\* all passing No. 16 sieve and not more than 5% retained on No. 30

A plasticizing admixture, subject to approval by the Engineer, shall be used in accordance with the manufacturer's recommendations.

The grout shall be mixed in a mechanical mixer, shall have the consistency of heavy paint, and shall be kept agitated until placed.

Members shall not be moved before the grout has set, ordinarily at least 24 hours at 80°F or higher.



**S-804.03.22.5--Finishing and Marking.** Units shall be given a Class 1 finish at the plant and shall be given a Class 2 finish after erection when required.

Recesses in girders at end of diaphragm bars, holes left by form ties, and other surface irregularities shall be carefully cleaned and patched with an approved non-shrink commercial grout or a non-shrinkage mortar of the following composition:

- 1 part Type 1 cement
- 1 1/2 to 2 parts fine sand
- 1/2 to 3/4 ounces aluminum powder per bag of cement
- Approved admixture per S-713.02.
- Sufficient water to produce a workable but rather stiff mix.

The units shall be clearly marked in accordance with MDOT SOP.

**S-804.03.22.6--Handling, Storage, and Installation.** Posttensioned members may be handled immediately after completion of stressing and grout has set. Pretensioned members may be handled immediately after release of tensioning. In either case, the members shall have developed a minimum compressive strength of 4000 psi prior to handling. In the event stressing is not done in a continuous operation, members shall not be handled before they are sufficiently stressed, as determined by the Engineer, to sustain all forces and bending moments due to handling. In the handling, storage, and transporting of beams or girders, they shall be maintained in an upright position (position as cast) at all times and shall be picked up from points within distance from beam ends equal to beam depth or at pick-up points designated on the plans. Disregard of this requirement and dropping of units may be cause for rejection, whether or not injury to the unit is apparent. Piles shall be picked up and loaded for shipment at points shown by the suspension diagram on the plans. Extreme care shall be used in handling and storing piles to prevent damage. The dropping of a pile may be cause for rejection of same, whether or not there is apparent injury to the member.

Care shall be exercised during the storage, hoisting, and handling of prestressed units to prevent damage. Damaged units shall be replaced by the Contractor at no additional costs to the Project.

When members are stacked for storage, each layer shall be supported at or near the pick-up points. Supports shall be carefully placed in a vertical line in order that the weight of any member will not stress an underlying member. To prevent damage in moving members it is suggested that rigid supports be covered with a cushion of wood or other resilient material.

Members shall not be transported until at least one day after the concrete has reached a compressive strength of 5,000 psi or greater strength when shown on the plans.

Piles used in salt water shall not be driven until concrete is seven days old, and air-entrained concrete shall be used in such piles.

After prestressed concrete voided slab units are set, doweled and bolted in their final position the keyways and dowel holes shall be filled with an approved non-shrink grout. Traffic shall not be permitted on the spans for 24 hours after grouting, and heavy construction equipment exceeding 15 tons will not be permitted on the spans for a period of 72 hours after grouting.

Adjacent slab units that mismatch more than one-fourth inch shall be adjusted prior to grouting of the shear keys. The maximum deviation from cross-section and grade (exclusive of camber) at any point shall not exceed one-fourth inch; and when the surface is checked with a ten-foot straightedge applied both parallel and perpendicular to the centerline, the variance shall not exceed one-fourth inch.

In addition to the requirements set out in this section, the applicable requirements of S-803 shall apply.

**S-804.03.22.7--Tolerances for Accepting Prestressed Concrete.** Member shall meet the dimension tolerances set by Division VII of PCI Quality Control Manual, 4th Edition.

**S-804.03.22.8--Testing of Materials.** Concrete and aggregate testing shall meet the requirements of Division VI of PCI Quality Control Manual, 4th Edition, except that the concrete mix design shall meet the requirements of S-804.02.10 "Portland Cement Concrete Mix Design". Also, in addition to concrete compressive tests samples made for detensioning and 28-day strength, test samples shall be made and tested in order to prove compliance to the requirements of S-804.03.22.6 for handling and shipping prestressed members. Compressive strength test cylinders for detensioning, handling and shipping shall receive the same type curing as the prestressed members for which they represent. Compressive strength samples shall be made each day for each prestress casting bed.

**S-804.03.22.9--Testing Personnel.** Technicians testing Portland cement concrete used in the production of prestressed members shall be PCI Quality Control Technician/Inspector Certified. Each producer of prestressed members shall have at least one PCI Level II certified technician on site during production for State Aid projects.

**S-804.03.22.10--Documentation.** The Prestressed Producer for each Prestressed concrete bridge member shall maintain documentation as set forth in MDOT SOPs. Testing and inspection record forms shall be approved by the MDOT Central Laboratory and as a minimum contain information listed in Division VI of PCI Quality Control Manual, 4th Edition.

**S-804.03.22.11--Use in the Work.** Before any Prestressed member is incorporated into the work, documentation as described in S-804.03.22.10 is required along with visual inspection of the member at the bridge construction site. The Engineers personnel will make visual inspection of the prestressed member at the bridge construction site.

**S-804.04--Method of Measurement.** Concrete, complete and accepted, will be measured in cubic yards. The concrete volume will be computed from the neat dimensions shown on the plans, except for such variations as may be ordered in writing by the Engineer. The quantity of concrete involved in fillets, scorings, and chamfers one square inch or less in cross-sectional area will be neglected. Deductions shall be made for the following:

- (1) The volume of structural steel, including steel piling encased in concrete.
- (2) The volume of timber piles encased in concrete, assuming the volume to be 0.80 cubic foot per linear foot of pile.
- (3) The volume of concrete piles encased in concrete.

No deduction will be made for the volume of concrete displaced by steel reinforcement, floor drains, or expansion joint material that is one inch or less in width normal to the centerline of the joint. Where railing is bid as a separate item, that portion of the railing above the top of the curb, above the surface of the sidewalk, or above the bridge roadway, as the case may be, will not be included in the measurement of concrete, but will be measured as railing. Massive pylons or posts which are to be excepted from payment for railing and are intended to be measured for as concrete will be so noted on the plans.

When shown on the plans or directed by the Engineer, concrete placed as a seal for cofferdams will be measured by the cubic yard actually in place, except that no measurement will be made of seal concrete placed outside of an area bounded by vertical planes 18 inches outside the neat lines of the footing as shown on the plans or as directed and parallel thereto.

Reinforcing steel will be measured and paid for in pounds as set out in S-805.

Unless otherwise specified, structural steel will be measured and paid for as set out in S-810.

Excavation for bridges will be measured and paid for as in S-801.

Piling will be measured and paid for as set out in S-802 and S-803.

Railing will be measured and paid for as set out in S-813.

Prestressed concrete beams will be measured by the linear foot.

Prestressed concrete voided slab units, interior and exterior with railing, and precast concrete caps, intermediate and end cap with winged abutment wall, of the size and type specified will be measured by the unit complete in place and accepted. Railing, winged abutment walls, grout, tie rods, nuts, washers, bearing pads and other appurtenances will not be measured for separate payment.

**S-804.05--Basis of Payment.** Concrete will be paid for at the contract unit price per cubic yard for the class or classes specified, complete in place. Prestressed concrete beams will be paid for at the contract unit per linear foot of specified size and type.

Concrete pile encasement will be paid for at the contract unit price per cubic yard for the class or classes specified, complete in place.

The quantity of concrete to paid for shall be the product of multiplying the total length encased by the volume per cubic yard as set forth on applicable standard drawing(s).

Payment at the contract unit prices bid shall be full compensation for furnishing all materials, equipment, tools, labor and incidentals necessary to complete the work.

Payment will be made under:

**S-804-A:** Bridge Concrete, Class \_\_\_\_\_ - per cubic yard

**S-804-B:** Box Bridge Concrete, Class \_\_\_\_\_ - per cubic yard

**S-804-C:** \_\_\_\_\_ ‘ Prestressed Concrete Beam, Type \_\_\_\_\_ - per linear foot  
(Length)

**S-804-D:** \_\_\_\_\_ Prestressed Concrete Modified Pile Beams - per linear foot  
(Size)

## **SECTION S-805 - REINFORCEMENT**

**S-805.01--Description.** This work shall consist of furnishing and placing steel reinforcement for bridges in accordance with these specifications and in reasonably close conformity with the dimensions, bending, spacing, and other requirements shown on the plans.

**S-805.02--Materials.** Materials used shall conform with the requirements of S-711.

Supports for bar reinforcement shall meet the requirements of S-711.02.7.

**S-805.02.1--Order Lists.** Before ordering reinforcement, all order lists and bending diagrams shall be furnished by the Contractor for the approval of the Engineer, and no materials shall be ordered until the lists and bending diagrams have been approved. The approval of order lists and bending diagrams by the Engineer shall in no way relieve the Contractor of responsibility for their correctness. All expense incidental to the revision of material furnished in accordance with such lists and diagrams to make it comply with the design drawings shall be borne by the Contractor.

Order lists for box bridges shall conform to the provisions and requirements of S-602.

### **S-805.03--Construction Requirements.**

**S-805.03.1--Protection of Material.** Steel reinforcement shall be protected at all times from damage. Damaged material will not be approved for use in the work. When placed in the work and immediately prior to placing the concrete, the reinforcement shall be free from dirt, oil, paint, grease, and other foreign substances and shall be free of loose or thick rust or millscale which could impair bond of the steel with the concrete.

**S-805.03.2--Fabrication.** Bent bar reinforcement shall be cold bent to the shapes shown on the plans, and unless otherwise provided on the plans or by authorization, bends shall be made in accordance with S-711.02. Bars partially embedded in concrete shall not be field bent except as shown on the plans or permitted.

Bar reinforcement shall be shipped in standard bundles and tagged and marked in accordance with Code of Standard Practice of the Concrete Reinforcing Steel Institute.

**S-805.03.3--Placing and Fastening.** Reinforcement shall be accurately placed in the positions shown on the plans and firmly held during the placing and setting of concrete.

Bars shall be tied at all intersections; except where spacing is less than one foot in each direction, alternate intersections shall be tied.

Distances from the forms shall be maintained by means of stays, blocks, ties, hangers, or other approved supports. Blocks for holding reinforcement from contact with the forms shall be precast mortar blocks of approved shape and dimensions or approved metal chairs. Layers of bars shall be separated by precast mortar blocks or by other equally suitable devices. The use of pebbles, pieces of broken stone or brick, metal pipe, and wooden blocks will not be permitted. The clear distance between parallel bars (except in columns and between multiple layers of bars in beams) shall not be less than the nominal diameter of the bars,  $1 \frac{1}{3}$  times the maximum size of the coarse aggregate, nor one inch.

Where reinforcement in beams or girders is placed in two or more layers, the clear distance between layers shall not be less than one inch, and the bars in the upper layers shall be placed directly above those in the bottom layer.

In spirally reinforced and in tied columns, the clear distance between longitudinal bars shall not be less than  $1 \frac{1}{2}$  times the bar diameter,  $1 \frac{1}{2}$  times the maximum size of the coarse aggregate, nor  $1 \frac{1}{2}$  inches.

The clear distance between bars shall also apply to the clear distance between a contact splice and adjacent splices or bars.

Reinforcement in any member shall be inspected and approved by the Engineer before the placing of concrete begins. Concrete placed in violation of this provision may be rejected and removal and replacement of concrete and reinforcement required.

If fabric reinforcement is shipped in rolls, it shall be straightened into flat sheets before being placed.

**S-805.03.4--Splicing of Bars.** All reinforcement shall be furnished in the full lengths indicated on the plans. Splicing of bars, except when shown on the plans, will not be permitted without the written approval of the Engineer. Splices shall be staggered insofar as possible.

The minimum distance to the surface of the concrete shall be as specified on the plans. Reinforcement shall not be welded except if detailed on the plans or if authorized by the Engineer in writing.

Welding shall conform to the current AWS specifications for Recommended Practices for Welding Reinforcement Steel, Metal Inserts, and Connections in Reinforced Concrete Construction.

**S-805.03.5--Lapping of Mesh or Mats.** Sheets of mesh or bar mat reinforcement shall overlap each other sufficiently to maintain a uniform strength and shall be securely fastened at the ends and edges. The edge lap shall not be less than one mesh in width.

**S-805.03.6--Substitutions.** Substitutions of different size bars will be permitted only with specific authorization by the Engineer. If steel is substituted, it shall have an area equivalent to the design area or larger.

**S-805.03.7--Epoxy Coated Bars.**

**S-805.03.7.1--Repair of Damaged Epoxy Coating.** When required, damaged epoxy coating shall be repaired with patching material conforming to ASTM Designation: A 775. Repair shall be done in accordance with the patching material manufacturer's recommendations.

**S-805.03.7.2--Handling of Epoxy Coated Bars.** The Contractor shall use padded or non-metallic slings and padded straps to protect the coated reinforcement from damage. The bundled bars shall not be dropped or dragged and must be stored on wooded cribbing. If, in the opinion of the Engineer, the coated bars or plates have been damaged as a result of the Contractor's negligence, the material will be rejected. The Contractor may propose, for the approval of the Engineer, alternate precautionary measures.

**S-805.03.7.3--Placing of Epoxy Coated Bars.** Epoxy-coated reinforcing bars supported from formwork shall rest on coated wire bar supports, or on bar supports made of dielectric material or other acceptable materials. Wire bar supports shall be coated with dielectric material for a minimum distance of two inches from the point of contact with the epoxy-coated reinforcing bars. In walls having reinforcing bars, spreader bars where specified by the Engineer shall be epoxy coated. Proprietary combination bar clips and spreaders used in walls with epoxy-coated reinforcing bars shall be made of corrosion resistant material. Epoxy-coated reinforcing bars shall be fastened with nylon-, epoxy-, or plastic-coated tie wire or other acceptable materials.

## **COMPENSATION**

**S-805.04--Method of Measurement.** Steel reinforcement incorporated in bridge concrete and accepted will be measured in pounds based on the total computed weight for the sizes and lengths of bars, mesh or mats shown on the plans or authorized. Reinforcement for box bridge concrete will be measured and paid for in accordance with S-602.

Epoxy coated reinforcement bars, not included in other pay items, will be measured in pounds based on the computed weight from the theoretical weight of plain round bars of the same nominal size as shown in the table of areas and weights in S-711.

The weight of mesh will be computed from the theoretical weight of plain wire. If the weight per square foot is given on the plan, that weight will be used.

The weight of plain or deformed bars, or bar mat, will be computed from the theoretical weight of plain round bars of the same nominal size as shown in the table of area and weights in S-711.

The weight for payment of structural steel reinforcement, incorporated in the work and accepted, will be the theoretical weight of the material used.

The weight of reinforcement used in railings measured on a linear foot basis will not be measured. The weight of reinforcement in precast piles and other items where the reinforcement is included in the contract price for the item will not be measured.

No allowance will be made for clips, wire, separators, wire chairs, and other material used in fastening the reinforcement in place. If bars are substituted upon the Contractor's request and as a result more steel is used than specified, only the bars specified will be measured.

When splices, other than those shown on the plans, are made for the convenience of the Contractor, the extra steel will not be measured.

Concrete Encasement of Steel Piling. When shown on the plans or ordered, reinforcement placed in connection with pile encasement will be measured in pounds.

Measurement of reinforcement will be based on field measurement to determine the approved encased length.

The quantity of reinforcement per linear foot of encased piling shall be as indicated on the applicable contract drawing(s).

**S-805.05--Basis of Payment.** Reinforcement will be paid for at the contract unit price per pound, which shall be full compensation for completing the work specified.

Reinforcement for pile encasement will be paid for a the contract unit price per pound. The weight of reinforcement to be paid for shall be the product of multiplying the total approved length of piling encased by the weight per linear foot quantity as set fort on applicable contract drawing(s).

Payment will be made under:

**S-805-A:** Reinforcement - per pound

**S-805-B:** Reinforcement, Epoxy Coated - per pound



## **SECTION S-806 - PRECAST CONCRETE BRIDGES**

**S-806.01--Description.** This item shall consist of precast concrete caps, precast concrete spans (complete with post), bridge railing or concrete barrier rail and precast wings for bridges, all constructed in accordance with these specifications for the items of the contract which constitute the complete structure, all in reasonably close conformity with the dimensions and design indicated on the plans and placed on a prepared substructure to the lines and grades established by the Engineer.

**S-806.02--Materials.** The materials used in this construction, in addition to the general requirements of these specifications, shall conform (unless otherwise stipulated) to the requirements prescribed in S-700, for the particular kind and type of material specified.

**S-806.02.1--Sampling and Testing.** As referenced in S-106.03, approval of the source of supply of cement, fine and coarse aggregate, water, reinforcement and other materials used in the construction of the caps, slabs, wings and barrier rails and the results of tests showing their suitability for use shall be obtained prior to their use in any construction. Samples shall be submitted as directed.

The Contractor (or manufacturer), without extra compensation, shall supply the Engineer's representative (plant inspector) with the necessary materials and representative concrete mix for making a minimum of one (1) test cylinder of concrete for each seven (7) caps, slabs, wings or barrier rails, or a minimum of one (1) test cylinder per day if less than seven (7) caps, slabs, wings or barrier rails are constructed. Other test cylinders may be required by the Engineer to establish strength for handling these items. Cylinders are to be cured with the same method used in curing the caps, slabs, wings or barrier rails, as the case may be. Only those caps, slabs, wings or barrier rails bearing identification marks of acceptance by the MDOT laboratory or other approved laboratories will be permitted for use in the construction. The acceptance of any precast concrete member at the production plant shall in no way be final and further inspection will be made at the structure site before and after the member has been placed in its final position.

For casting facilities with PCI Certification, acceptance will be on the basis of Manufacture's Certification as documented by the Engineer from reports issued by MDOT or other State Aid approved laboratory. For casting facilities without PCI Certification, acceptance will be on the basis of test reports issued by a State Aid approved laboratory.

### **S-806.03 Construction Requirements.**

**S-806.03.1--General.** The methods of construction shall conform, unless otherwise stipulated, to the provisions and requirements prescribed in these specifications and indicated on the plans for the several items which constitute the complete structure.

**S-806.03.2--Substructure.** The substructure shall be constructed in conformity with S-803 and as indicated on the plans. Payment for same will be made under S-803, unless otherwise indicated.

The piles shall be so driven that the cap may be placed in its proper location without excessive manipulation of the piles.

Piles driven from the deck of the bridge under construction shall follow the construction requirements of S-806.03.5 below in regard to placing construction equipment on bridge.

**S-806.03.3--Precast Caps, Slabs, Wings and Barrier Rails.**

**S-806.03.3.1--Proportioning and Mixing Concrete.** The composition, proportioning and mixing of the concrete used in this construction shall be as specified in S-804, and shall be the class specified on the plans, or as approved by the State Aid Engineer.

**S-806.03.3.2--Reinforcing Steel.** Reinforcing steel shall be of the quality, type, and size specified on the plans and placed as indicated. It shall meet the requirements set out in S-711.02, as applicable.

Separate payment will not be made for reinforcing steel.

**S-806.03.3.3--Forms.** All forms shall be of metal or wood. They shall be built mortar-tight and of sufficient rigidity to prevent any distortion due to pressure of the concrete and other loads incident to the construction operations. The forms shall be substantial and unyielding and shall be so designed that the finished concrete will conform to the proper dimensions and contours. The design of the forms shall take into account the effect of vibration of concrete as it is placed.

Forms shall be filleted at all sharp corners and shall be given a bevel or draft in the case of all projections to ensure easy removal.

All forms shall be set and maintained true to the lines designated until the concrete is sufficiently hardened or for periods as hereinafter specified.

Forms shall be treated with oil immediately before placing concrete in them. Any material which will adhere to, or discolor, the concrete shall not be used. Extreme care shall be exercised to make sure that no oil gets on the reinforcing steel.

**S-806.03.3.4--Handling and Placing Concrete.** Prior to the placing of any concrete the forms shall be thoroughly cleaned of any construction debris and extraneous matter and the reinforcing bars (of the size and type indicated) placed and secured in the forms as indicated on the plans. Concrete shall not be deposited in the forms until the inspector has checked the placing of the reinforcement and has given his approval to proceed.

Ready mix concrete transported in a truck mixer or truck agitator shall be discharged at the site of the work and placed in its final position in the forms within one hour after the introduction of the mixing water to the cement and aggregate or the cement to the aggregate whichever occurs first; except that in abnormal weather, or under other conditions contributing to the quick stiffening of the concrete, the Engineer may make a determination of a lesser time for placement considering all factors affecting initial set of the concrete. When mixed concrete is transported in approved non-agitating trucks, the concrete shall be discharged at the work site within thirty minutes after the introduction of the mixing water to the cement and aggregate.

The concrete shall be placed so as to avoid segregation of the materials and the displacement of the reinforcement. Open troughs and chutes used shall be of metal or metal lined and shall be kept clean and free from coating of hardened concrete by flushing with water after each pour. Water used for flushing shall be discharged clear of the forms.

**S-806.03.3.5--Compaction.** Concrete during and immediately after depositing shall be thoroughly compacted by the use of vibrators and suitable spading tools. Vibration shall be applied at the point of deposit and in the area of freshly deposited concrete. The vibration shall be internal and shall be of sufficient duration and intensity to thoroughly compact the concrete, but shall not be continued so as to cause segregation. Vibration shall not be continued at any one point to the extent that localized areas of grout are formed.

The entire operation of depositing and consolidating the concrete shall be so conducted that the concrete shall be smooth, dense and free from any honeycomb or pockets of segregated aggregates. The roadway surface of slabs and tops of caps and wings shall be finished with a wood float.

Concrete in the precast members shall be placed in one continuous operation.

**S-806.03.3.6--Placing Bolts, Drains, Bolt Holes, etc.** All bolts, drains, bolt holes, etc., indicated on the plans as necessary (or desirable) shall be placed in the concrete at the locations indicated on the plans. They shall be formed by approved methods and operations and shall be such as to ensure proper connections.

**S-806.03.3.7--Removal of Forms and Curing.** Side forms for precast members may be removed after the concrete has attained sufficient strength to maintain a true section. The minimum time for removal, using alternate types of curing, is considered to be as follows:

Wetted burlap (three thicknesses minimum), cotton mats, or constant fogging (temperature less than 80°F and more than 40°F) 24 hours; (temperature 80°F and higher) 20 hours;

Steaming in enclosures at temperatures not less than 80°F and not more than 150°F, 12 hours;

When Type III Cement is permitted, side forms may be removed after 12 hours (all types of curing).

Bottom forms shall remain in place until the concrete has obtained a minimum compressive strength of 2500 psi (determined by cylinder tests) before removal. When the precast members are moved, they shall be deposited directly on a level hard-surfaced true-plane area without stacking and they shall remain undisturbed seven days while the curing shall continue beyond the period of initial handling.

Precast members shall be covered with wetted burlap immediately after the finishing operations.

Liquid membrane curing may be used, but shall be white pigmented and applied at the rate of not less than one gallon per 150 square feet of surface. The entire surface and exposed edges shall be sprayed with the membrane as soon as practicable after finishing is complete and as side forms are removed. The seal shall be applied to the surface as a fine mist which shall provide a continuous, uniform, water impermeable film. The bottom of the precast members shall be sealed with the membrane when they are removed from the bottom supporting forms. The Manufacturer may use steam curing. Steam curing shall be according to stipulations set out in S-804.03.22.4.2.

The cap, slab, wing and rail units shall not be shipped until the concrete has obtained the specified minimum compressive strength as determined by cylinder tests and shall be cured for a minimum of 14 or 21 days as indicated in the table below:

Compressive Strength Specified PSI	Requirements Prior to Shipment	
	Minimum Curing Days	Minimum Compressive Strength PSI
3000	14	3000
4000	21	4000
5000	21	5000

**S-806.03.4--Tolerance of Dimensions.**

**S-806.03.4.1--Caps.** The width and length of the caps shall not vary more than one-quarter (1/4) inch from the plan dimensions. The bottom of the cap shall be smooth and shall not vary more than one-eighth (1/8) of an inch when tested with a straight edge in a horizontal direction for any ten (10) foot length. The top of the caps shall not vary more than one-sixteenth (1/16) inch from the slope shown on the plans.

**S-806.03.4.2--Slabs.** The four sides of the slab shall not vary more than one-eighth (1/8) inch for the full depth of the slab when tested with a straight edge in a vertical direction, nor more than one-quarter (1/4) inch in full length of the slab when tested with a straight edge in a horizontal direction, nor shall the top of the slab vary more than one-eighth (1/8) inch in any ten (10) foot length.

**S-806.03.4.3--Wings.** The width and length of the wings shall not vary more than one-quarter (1/4) inch from the plan dimensions.

**S-806.03.4.4--Concrete Barrier Rail.** The width of the rail shall not vary more than one-eighth (1/8) inch and the length shall not vary more than (1/4) inch. The sides shall be smooth with no discolorations. In the event patching is required, the entire rail shall be given a Class 2 finish.

**S-806.03.5--Handling and Placing Precast Caps, Slabs, Barrier Rail and Wings.** The precast caps, slabs, barrier rail, and wings shall be handled in such a manner that they will not be subjected to excessive and undue abuse producing crushing, spalling, or undue marring of the concrete. Injury to units may be cause for rejection whether the injury to the unit is apparent or not. Damaged units shall be replaced by the Contractor at his expense.

Where the caps, slabs, barrier rail, and wings are to be loaded or stored in tiers, the blocking between the tier should be in a vertical plane so that the weight of the upper caps, slabs or wings cannot produce bending in those of a lower tier.

After the caps are set and doweled, welded, or grouted to the piling, the dowel holes shall be filled with grout or AC-13 before the slabs are set.

Each section (or unit) shall be placed as closely as possible to its final position in the structure so that the use of bars or other tools which might mar the concrete will be eliminated. The abutting edges of each slab unit shall be carefully cleaned of any concrete or extraneous matter in order that the longitudinal joints may be bolted tightly together.

When the abutment span is not a thirty-one foot (31') span and the total number of spans in the bridge is four or less, the Contractor shall set in place all precast units from the ground. The Contractor will be expected to drive piling and set units from the ground for the first two spans from each abutment, provided that the abutment span is a nineteen foot (19') span. When the bridge consists of a thirty-one foot (31') abutment span, or at any other time the Engineer has determined that it is not feasible or possible to construct any additional spans from the ground, then he may permit construction to continue with equipment on the bridge deck subject to the following:

- (1) Contractor will set in place all span units; install and tighten all bolts; grout; wait for a period of at least seventy-two (72) hours after grouting; and, if track/crawler type crane is used, place appropriate construction mats on the deck before putting crane on bridge.
- (2) Construction mats for use with track/crawler type cranes shall be made of timber with sufficient dimensions to prevent contact between the track and concrete surface and to prevent undue marring of concrete slab.
- (3) If pneumatic tire type crane is used, then it MUST be equipped with outriggers. Outriggers ARE NOT to be set directly on precast concrete slabs. They are to be set on timber mats with minimum dimensions of 5' X 5' - 6" thick.
- (4) After driving piling, the Contractor will set span units, install and tighten all bolts, grout and wait a minimum of seventy-two (72) hours before moving crane onto next span.
- (5) The seventy-two (72) hours minimum time period for placing equipment on bridge may be reduced to twelve (12) hours if approval is given to Contractor by the Bridge Engineer to use an epoxy grout. If a non-shrink commercial type grout is used, it may be reduced to twenty-four (24) hours.

Grout used to fill the keyways and dowel holes shall be either the non-shrink commercial type, epoxy type or the standard 1, 2, 3 mix type and be subject to one of the following as applicable.

- (1) If the non-shrink type grout is used, it must be on the MDOT Testing Division's List of Approved Grout Materials or must be tested and approved by the MDOT prior to use. Non-shrink grout shall develop a minimum compressive strength (cubes) of 3,000 psi in twenty-four (24) hours. The grouting materials must be proportioned, mixed, and applied in accordance with the manufacturer's recommendation. The Contractor must furnish, with each new lot of material shipped, certification from the manufacturer showing that the material is of the same composition as that originally approved by the MDOT and that the material has not been in any way changed or altered.
- (2) Epoxy grout shall be composed of one (1) part epoxy (binder) and three (3) parts dry silica sand, (bagged 1 cu. ft. per bag), measured by volume. Epoxy grout shall develop a minimum compressive strength of 5,000 psi in twelve (12) hours. Contractor shall submit method of sampling and testing, to verify strength requirement, to the Bridge Engineer for approval prior to using.
- (3) The 1, 2, 3 mix type grout shall be composed of one part cement, two parts sand and three parts coarse aggregate with maximum size of aggregate being three-eighths (3/8)inch.

Traffic shall not be permitted on the spans for twenty-four (24) hours and heavy construction type traffic, or other loads exceeding fifteen (15) tons, shall not be permitted on the spans for a period of seventy-two (72) hours after grouting of last span is complete. If epoxy grout is used, these time requirements may be reduced to twelve (12) hours.

If a non-shrink commercial type grout is used the seventy-two (72) hours time requirement may be reduced to twenty-four (24) hours.

Neoprene rubber bearing pads with a minimum thickness of one-fourth (1/4) inch and meeting the requirements of S-714.10.1 shall be placed between all bearing points of the slabs and surfaces of the caps. Other materials as approved by the Engineer with the concurrence of the State Aid Bridge Engineer meeting the thickness requirements above may be substituted for the neoprene rubber bearing pads.

**S-806.03.5.1--Transverse Joints.** When the completed bridge is to consist of more than one span, there shall be placed in the joint between spans a bituminous premolded joint filler one-quarter (1/4) inch in thickness. This joint filler shall be for the full thickness of the concrete (less one inch at the top of the slab) and for the full width of the structure, including the curb. When the spans are completely in place and bolted the transverse joints shall be sealed with AC-13 or other joint sealer approved by the Engineer.

**S-806.03.5.2--Railing.** The bridge railing shall be installed after all other work on the bridge has been completed.

The material used shall meet the dimensions and requirements specified on the plans and the railing shall be constructed in conformity with the details indicated and to the lines and grades established.



### COMPENSATION

**S-806.04--Method of Measurement.** Precast concrete slabs will be measured by the unit, interior unit, exterior unit, or exterior unit with curb, complete in place, bolted, and grouted.

Precast concrete caps will be measured by the unit, end unit or intermediate unit, complete in place and securely fastened to the piling by welding to the steel plate in the cap or epoxied to concrete pile in the cap.

Precast concrete wings will be measured by the unit (one unit consists of one wing on each side and end of the abutment cap) complete in place and securely fastened to the caps with bolts.

Railing, complete in place, will be measured by the linear foot unless otherwise indicated on the plans.

**S-806.08--Basis of Payment.** Precast slabs and caps will be paid for at the contract price bid per each for each precast concrete span (curb unit), precast concrete span (interior unit), precast concrete cap (end unit) and precast concrete cap (intermediate unit), as the case may be, complete and accepted, which price shall be full compensation for furnishing all materials (including all reinforcement, bolts, washers, expansion joint material, dowels, welding, grout, etc., required) and for all loading, hauling, unloading, placing and for all labor, equipment, tools and incidentals necessary to complete the work.

The precast wings will be paid for at the contract price bid per each (one wing on one corner) complete and accepted, which price shall be full compensation for furnishing all materials (including all reinforcement, bolts, etc., required) and for all loading, hauling, unloading, and placing; and for all labor, equipment, tools, and incidentals necessary to complete the work.

The bridge railing will be paid for at the contract price bid per linear foot for railing of the type specified on the plans, complete and accepted, which price shall be full compensation for furnishing all materials (including blocks, bolts, washers, posts, etc.) for all painting and for all labor, equipment, tools, and incidentals necessary to complete the work.

Payment will be made under:

- S-806-A:** \_\_\_' Precast Concrete Slab Unit, \_\_\_' Interior - per each
- S-806-B:** \_\_\_' Precast Concrete Slab Unit, Curb - per each
- S-806-C:** \_\_\_' Precast Concrete Slab Unit, \_\_\_' Exterior - per each
- S-806-D:** \_\_\_' Precast Concrete Slab Unit, \_\_\_' Interior, \_\_\_° Skew, \_\_\_ Fwd. - per each
- S-806-E:** \_\_\_' Precast Concrete Slab Unit, Curb, \_\_\_° Skew, \_\_\_ Fwd. - per each
- S-806-F:** \_\_\_' Precast Concrete Slab Unit, \_\_\_' Exterior, \_\_\_° Skew, \_\_\_ Fwd. - per each
- S-806-G:** Precast Concrete Barrier Rail - per linear foot
- S-806-H:** Beam Type Railing with Concrete Posts - per linear foot
- S-806-I:** \_\_\_' Precast Concrete Cap,  
Intermediate Unit, \_\_\_\_\_ Pile - per each  
(Steel, Concrete or Timber)
- S-806-J:** \_\_\_' Precast Concrete Cap, End Unit, \_\_\_\_\_ Pile - per each  
(Steel, Concrete or Timber)
- S-806-K:** \_\_\_' Precast Concrete Cap, Intermediate Unit, \_\_\_\_\_ Pile, - per each  
\_\_\_\_° Skew, \_\_\_ Fwd. (Steel, Concrete or Timber)
- S-806-L:** \_\_\_' Precast Concrete Cap, End Unit, \_\_\_\_\_ Pile, - per each  
\_\_\_\_° Skew, \_\_\_ Fwd. (Steel, Concrete or Timber)
- S-806-M:** \_\_\_' Precast Concrete Wing - per each

**Sections S-807 thru S-809 - Blank.**

## **SECTION S-810 - STEEL STRUCTURES**

**S-810.01--Description.** This work shall consist of furnishing, fabricating, preparing, assembling, erecting, and painting structural steel and all accessories and other metal parts required in steel spans. This work shall be constructed as indicated on the plans, in reasonably close conformity with the lines, grades, dimensions, and design shown, and in accordance with the applicable provisions and requirements in other sections of these specifications for the different items which constitute the complete structure.

These specifications apply to bolted and welded construction.

### **FABRICATION**

#### **S-810.02--Materials.**

**S-810.02.1--General.** Unless otherwise specified, structural steel, miscellaneous metals, and paints shall conform to the applicable requirements of this section and S-710, S-716, S-717 and S-814. Unless otherwise specified, structural carbon steel shall be per ASTM Designation: A 36.

**S-810.02.2--Drawings.** The Contractor shall prepare shop drawings for all materials to be fabricated. The size of the sheets (36"x24") on which the drawings are prepared shall conform to the standard bridge sheet of the Office of State Aid Road Construction. Two complete sets of prints shall be submitted to the Engineer for approval, with concurrence of the State Aid Bridge Engineer, prior to ordering any materials for fabrication.

For all fabrication to be done by welding, two copies of welding procedures in accordance with the provisions of ANSI/AASHTO/AWS D1.5 Bridge Welding Code, hereinafter referred to as the Welding Code, shall also be submitted to the Engineer for approval with concurrence of the State Aid Bridge Engineer. After final approval of the shop drawings and welding procedures, if applicable, two complete sets of prints shall be submitted to the Engineer. As required by special conditions, the Engineer shall be furnished with as many additional sets of prints as may be necessary. Shop drawings for railroad bridges shall be prepared with ink on linen tracing cloth or other approved equal, which shall be delivered to the Engineer prior to final acceptance of the project. No changes shall be made in a shop drawing after it has been approved, nor shall steel sections different from those shown on the plans be substituted except with the written consent or direction of the Engineer.

Prior to the fabrication of any part of a structure, shop drawings and welding procedures for that part of the structure shall have been given final, unconditional, approval by the Engineer with concurrence of the State Aid Bridge Engineer. Work performed prior to approval of drawing and procedures may be rejected.

**S-810.02.3--Shop Painting.** Shop painting, unless otherwise designated or permitted, shall consist of inorganic zinc primer, S-710, applied as specified in S-814. Machine finished surfaces of pins, pin rollers and bores shall be coated as soon as practicable after acceptance with a heavy coat of Petrolatum meeting the requirements of ASTM Designation: D 217, NLGI Consistency grade 2 or 3 or other approved coating prior to removal from the shop.

**S-810.02.4--Storage of Materials.** Structural material, either plain or fabricated, shall be stored at the bridge shop above ground on platforms, skids, or other supports. It shall be kept free from dirt, grease, and other foreign matter and shall be protected as far as practicable from corrosion.

**S-810.02.5--Straightening Material.** Rolled material, before being laid off or worked, must be straight. If straightening is necessary, it shall be done by methods that will not injure the metal. Heat straightening of ASTM Designation: A514/A517 steel shall be done only under rigidly controlled procedures and each application subject to the approval of the Engineer. In no case shall the maximum temperature of the steel exceed 1125°F. Sharp kinks and bends will be cause for rejection of the material.

**S-810.02.6--Curving Rolled Beams and Welded Girders.** Steels that are manufactured to a yield point greater than 50,000 psi shall not be heat curved.

**S-810.02.6.1--Type of Heating.** Beams and girders may be curved by either continuous or V-type heating as approved by the Engineer. For the continuous method, a strip along the edge of the top and bottom flange shall be heated simultaneously; the strip shall be of sufficient width and temperature to obtain the required curvature. For the V-type heating, the top and bottom flanges shall be heated in truncated triangular or wedge-shaped areas having their bases along the flange edge and spaced at regular intervals along each flange; the spacing and temperature shall be as required to obtain the required curvature, and heating shall progress along the top and bottom flange at approximately the same rate.

For the V-type heating, the apex of the truncated triangular area applied to the inside flange surface shall terminate just before the juncture of the web and the flange is reached. To avoid unnecessary web distortion, special care shall be taken when heating the inside flange surface so the heat is not applied directly to the web. When the radius of curvature is 1000 feet or more, the apex of the truncated triangular heating pattern applied to the outside flange surface shall extend to the juncture of the flange and web. When the radius of curvature is less than 1000 feet, the apex of the truncated triangular heating pattern applied to the outside flange surface shall extend past the web for a distance equal to 1/8 of the flange or 3 inches, whichever is less. The truncated triangular pattern shall have an included angle of approximately 15 to 30 degrees, but the base of the triangle shall not exceed 10 inches. Variations in the patterns prescribed above may be made with the approval of the Engineer.

For both types of heating, the flange edges to be heated are those that will be on the inside of the horizontal curve after cooling. Heating both inside and outside flange surfaces is only mandatory when the flange thickness is 1 1/4 inches or greater; in which case, the two surfaces shall be heated concurrently. The maximum temperature shall be as prescribed below.

**S-810.02.6.2--Temperature.** The heat-curving operation shall be conducted in such a manner that the temperature of the steel does not exceed 1150°F as measured by temperature indicating crayons or other suitable means. The girder shall not be artificially cooled until after naturally cooling to 600°F. The method of artificial cooling is subject to the approval of the Engineer.

**S-810.02.6.3--Position for Heating.** The girder may be heat-curved with the web in either a vertical or a horizontal position. When curved in the vertical position, the girder shall be braced or supported in such a manner that the tendency of the girder to deflect laterally during the heat-curving process will not cause the girder to overturn.

When curved in the horizontal position, the girder must be supported near its ends and at intermediate points, if required, to obtain a uniform curvature; the bending stress in the flanges due to the dead weight of the girder must not exceed the usual allowable design stress. When the girder is positioned horizontally for heating, intermediate safety catch blocks must be maintained at the mid-length of the girder within two inches of the flanges at all times during the heating process to guard against a sudden sag due to plastic flange buckling.

**S-810.02.6.4--Sequence of Operations.** The girder shall be heat curved in the fabrication shop before it is painted. The heat curving operation may be conducted either before or after all the required welding of transverse intermediate stiffeners is completed. However, unless provisions are made for girder shrinkage, connection plates and bearing stiffeners shall be located and attached after heat curving. If longitudinal stiffeners are required, they shall be heat curved or oxygen cut separately and then welded to the curved girder. When cover plates are to be attached to rolled beams, they may be attached before heat curving if the total thickness of one flange and cover plate is less than 2 1/2 inches and the radius of curvature is greater than 1000 feet. For other rolled beams with cover plates, the beams must be heat-curved before the cover plates are attached; cover plates must be either heat-curved or oxygen cut separately and then welded to the curved beam.

**S-810.02.6.5--Camber.** Girders shall be cambered before heat curving. Camber for rolled beams may be obtained by heat-cambering methods approved by the Engineer. For plate girders, the web shall be cut to the prescribed camber with suitable allowance for shrinkage due to cutting, welding, and heat curving. The heat-curving process may tend to change the cervical camber present before heating. This effect will be most pronounced when the top and bottom flanges are of unequal widths on a given transverse cross section. However, subject to the approval of the Engineer, moderate deviations from specified camber may be corrected by a carefully supervised application of heat.

**S-810.02.6.6--Measurement of Curvature and Camber.** Horizontal curvature and vertical camber shall not be measured for final acceptance before all welding and heating operations are completed, and the flanges have cooled to a uniform temperature. Horizontal curvature shall be checked with the girder in the vertical position by measuring off-sets from a string line or wire attached to both flanges or by using other suitable means. Camber shall be checked by adequate means.

**S-810.02.7--Finish.** Portions of work exposed to view shall be finished neatly. Shearing, flame cutting, and chipping shall be done carefully and accurately.

**S-810.02.8--Bolt Holes.** All holes for bolts shall be either punched or drilled. Material forming parts of a member composed of not more than five thicknesses of metal may be punched 1/16 inch larger than the nominal diameter of the bolts whenever the thickness of the metal is not greater than 3/4 inch for structural steel, 5/8 inch for high strength steel, or 1/2 inch for quenched and tempered alloy steel, unless subpunching and reaming is required under S-810.02.11.1.

When there are more than five thicknesses or when any of the main material is thicker than 3/4 inch for structural steel, 5/8 inch for high strength steel, or 1/2 inch for quenched and tempered alloy steel, all holes shall either be subdrilled or drilled full size.

When required under S-810.02.11, all holes shall be either subpunched or subdrilled 3/16 inch smaller and after assembling, reamed 1/16 inch larger or drilled full size to 1/16 inch larger than the nominal diameter of bolts. Hole shall be subdrilled if thickness limitation governs.

**S-810.02.9--Punched Holes.** The diameter of the die shall not exceed the diameter of the punch by more than 1/16 inch. If any holes must be enlarged to admit the bolts, such holes shall be reamed. Holes must be clean cut without torn or ragged edges. Poor matching of holes will be cause for rejection.

**S-810.02.10--Reamed or Drilled Holes.** Reamed or drilled holes shall be cylindrical, perpendicular to the member, and shall comply with the requirements of S-810.02.8 as to size. Where practicable, reamers shall be directed by mechanical means. Burrs on the outside surfaces shall be removed. Poor matching of holes will be cause for rejection. Reaming and drilling shall be done with twist drills. If required by the Engineer, assembled parts shall be taken apart for removal of burrs caused by drilling. Connecting parts requiring reamed or drilled holes shall be assembled and securely held while being reamed or drilled and shall be match marked before disassembling.

**S-810.02.11--Preparation of Field Connections.**

**S-810.02.11.1--Sub-punching and Reaming of Field Connections.** Unless otherwise specified, holes in all field connections and field splices of main members of trusses, arches, continuous beam spans, bents, towers (each face), plate girders, and rigid frames shall be sub-punched (or drilled if sub-drilling is required by S-810.02.8), and subsequently reamed while assembled or to a steel template, as required by S-810.02.16.

All holes for floorbeam and stringer field end connections shall be subpunched and reamed to a steel template or reamed while assembled.

Reaming or drilling full size of field connection holes through a steel template shall be done after the template has been located with utmost care as to position and angle and firmly bolted in place. Templates used for reaming matching members, or the opposite faces of a single member, shall be exact duplicates. Templates used for connections on like parts or members shall be accurately located so that the parts or members are duplicates and require no match-marking.

For any connection, in lieu of subpunching and reaming or subdrilling and reaming, the fabricator may, at his option, drill holes full size with all thicknesses of material assembled in proper position.

If additional subpunching and reaming is required, it shall be as specified on the plans.

**S-810.02.11.2--Numerically-Controlled Drilled Field Connections.** Alternately, for any connection or splice designated in S-810.02.11.1, in lieu of sub-sized holes and reaming while assembled, or drilling holes full-size while assembled, the Contractor shall have the option to drill bolt holes full-size in unassembled pieces and/or connections including templates for use with matching sub-sized and reamed holes by means of suitable numerically-controlled (N/C) drilling equipment subject to the specific provisions contained in this article.

If N/C drilling equipment is used, the Engineer, unless otherwise stated in the special provisions or on the plans, may require the Contractor, by means of check assemblies, to demonstrate that this drilling procedure consistently produces holes and connections meeting the requirements of S-810.02.13 and S-810.02.16.

The Contractor shall submit to the Engineer for approval with concurrence of the State Aid Bridge Engineer a detailed outline of the procedures that he proposes to follow in accomplishing the work from initial drilling through check assembly, and, if required, to include the specific members of the structure that may be N/C drilled, the sizes of the holes, the location of common index and other reference points, composition of check assemblies, and all other pertinent information.

Holes drilled by N/C drilling equipment shall be drilled to appropriate size either through individual pieces or any combination of pieces held tightly together.

**S-810.02.12--Accuracy of Punched and Drilled Holes.** All holes punched full size, subpunched, or subdrilled shall be so accurately punched that after assembling (before any reaming is done) a cylindrical pin 1/8 inch smaller in diameter than the nominal size of the punched hole may be entered perpendicular to the face of the member, without drifting, in at least 75 percent of the contiguous holes in the same plane. If this requirement is not fulfilled, the badly punched pieces will be rejected. If any hole will not pass a pin 3/16 inch smaller in diameter than the nominal size of the punched hole, this will be cause for rejection.

**S-810.02.13--Accuracy of Reamed and Drilled Holes.** When holes are reamed or drilled, 85 percent of the holes in any contiguous group shall, after reaming or drilling, show no offset greater than 1/32 inch between adjacent thicknesses of metal.

All steel templates shall have hardened steel bushings in holes accurately dimensioned from the center lines of the connection as inscribed on the template. The center lines shall be used in accurately locating the template from the milled or scribed ends of the members.

**S-810.02.14--Fitting for Bolting.** Surfaces of metal in contact shall be cleaned before assembling. The parts of a member shall be assembled, well pinned, and firmly drawn together with bolts before reaming is commenced. Assembled pieces shall be taken apart, if necessary, for the removal of burrs and shavings produced by the reaming operation. The member shall be free from twists, bends, and other deformation.

End connection angles, stiffener angles, and similar parts shall be carefully adjusted to correct position and bolted, clamped, or otherwise firmly held in place until riveted.

Parts in the shop shall be secured by bolts, insofar as practicable, to prevent damage in shipment and handling.



**S-810.02.15—Blank.****S-810.02.16--Shop Assembling.**

**S-810.02.16.1-General.** The field connections of main members of trusses, arches, continuous beam spans, bents, towers (each face), plate girders, and rigid frames shall be assembled in the shop with milled ends of compression members in full bearing, and then shall have their sub-size holes reamed to specified size while the connections are assembled.

Assembly shall be Full Truss or Girder Assembly unless Progressive Truss or Girder Assembly, Full Chord Assembly, Progressive Chord Assembly, or Special Complete Structure Assembly is specified in the special provisions or on the plans. Modifications to these assemblies may be allowed when approved in writing by the Engineer with concurrence of the State Aid Bridge Engineer.

When required on the plans, check assemblies and N/C drilled field connections shall be in accordance with the provisions of S-810.02.16.7.

Each assembly, including camber, alignment, accuracy of holes, and fit of milled joints, shall be approved by the Engineer, with concurrence of the State Aid Bridge Engineer, before reaming is commenced or before an N/C drilled check assembly is dismantled.

A camber diagram shall be furnished the Engineer by the Fabricator showing the camber at each panel point of each truss, arch rib, continuous beam line, plate girder, or rigid frame. Fraction points of span lengths shall be 1/4 points minimum, 1/10 points maximum. When the shop assembly is full truss or girder assembly or special complete structure assembly, the camber diagram shall show the camber measured in assembly. When any of the other methods of shop assembly is used, the camber diagram shall show calculated camber.

**S-810.02.16.2--Full Truss or Girder Assembly.** Full truss or girder assembly shall consist of assembling all members of each truss, arch rib, bent, tower face, continuous beam line, plate girder, or rigid frame at one time.

**S-810.02.16.3--Progressive Truss or Girder Assembly.** Progressive truss or girder assembly shall consist of assembling initially for each truss, arch rib, bent, tower face, continuous beam line, plate girder, or rigid frame at least three contiguous shop sections or all members in at least three contiguous panels but not less than the number of panels associated with three contiguous chord lengths (i.e., length between field splices) and not less than 150 feet in the case of structures longer than 150 feet. At least one shop section or panel or as many panels as are associated with a chord length shall be added at the advancing end of the assembly before any member is removed from the rearward end, so that the assembled portion of the structure is never less than that specified above.

**S-810.02.16.4--Full Chord Assembly.** Full chord assembly shall consist of assembling, with geometric angles at the joints, the full length of each chord of each truss or open spandrel arch, or each leg of each bent or tower, then reaming their field connection holes while the members are assembled and reaming the web member connection to steel templates set at geometric (not cambered) angular relation to the chord lines.

Field connection holes in web members shall be reamed to steel templates. At least one end of each web member shall be milled or shall be scribed normal to the longitudinal axis of the member and the templates at both ends of the member shall be accurately located from one of the milled end or scribed lines.

**S-810.02.16.5--Progressive Chord Assembly.** Progressive chord assembly shall consist of assembling contiguous chord members in the manner specified for full chord assembly and in the number and length specified for progressive truss or girder assembly.

**S-810.02.16.6--Special Complete Structure Assembly.** Special complete structure assembly shall consist of assembling the entire structure, including the floor system. This procedure is ordinarily needed only for complicated structures such as those having curved girders, or extreme skew in combination with severe grade or camber, and will be required only when so indicated on the plans.

**S-810.02.16.7--Check Assemblies with Numerically Controlled Drilled Field Connections.** When required, a check assembly shall be fabricated for each major structural type and shall consist of at least three contiguous shop sections or, in a truss, all members in at least three contiguous panels but not less than the number of panels associated with three contiguous chord lengths (i.e., length between field splices). Check assemblies should be based on the proposed order of erection, joints in bearings, special complex points, and similar considerations. Such special points could be the portals of skewed trusses, etc.

Use of either geometric angles (giving theoretically zero secondary stresses under dead-load conditions after erection) or cambered angles (giving theoretically zero secondary stresses under no-load conditions) should be designated on the plans or in the special provisions.

The check assemblies shall preferably be the first such section of each major structural type to be fabricated.

No match-marking and no shop assemblies other than the check assemblies will be required.

If the check assembly fails in some specific manner to demonstrate that the required accuracy is being obtained, further check assemblies may be required by the Engineer for which there shall be no additional cost to the Project.

**S-810.02.17--Drifting of Holes.** The drifting done during assembling shall be only such as to bring the parts into position and not sufficient to enlarge the holes or distort the metal. If any holes must be enlarged to admit the bolts, they shall be reamed.

**S-810.02.18--Match-Marking.** Connecting parts assembled in the shop for the purpose of reaming holes in field connections shall be match-marked, and a diagram showing such marks shall be furnished to the Engineer.

**S-810.02.19--Blank.**

**S-810.02.20--Bolts and Bolted Connections.** Bolted connections fabricated with high strength bolts shall conform to S-810.02.21.

**S-810.02.20.1--General.** Bolts shall be unfinished, turned, or ribbed bolts conforming to the requirements for Grade A Bolts or Specification for Low-Carbon Steel Externally and Internally Threaded Standard Fasteners, ASTM Designation: A 307. Bolted connections shall be used only as indicated by the plans or special provisions. Bolts shall have single self-locking nuts or double nuts unless otherwise shown on the plans or in the special provisions. Beveled washers shall be used where bearing faces have a slope of more than 1:20 with respect to a plane normal to the bolt axis.

**S-810.02.20.2--Unfinished Bolts.** Unfinished bolts shall be furnished unless other types are specified.

**S-810.02.20.3--Turned Bolts.** The surface of the body of turned bolts shall meet the ANSI roughness rating value of 125. Heads and nuts shall be hexagonal with standard dimensions for bolts of the nominal size specified or the next larger nominal size. Diameter of threads shall be equal to the body of the bolt or the nominal diameter of the bolt specified. Holes for turned bolts shall be carefully reamed with bolts furnished to provide for light driving fit. Threads shall be entirely outside of the holes. A washer shall be provided under the nut.

**S-810.02.20.4--Ribbed Bolts.** The body of ribbed bolts shall be of an approved form with continuous longitudinal ribs. The diameter of the body measured on a circle through the points of the ribs shall be 5/64 inch greater than the nominal diameter specified for the bolts.

Ribbed bolts shall be furnished with round heads conforming to ANSI B 18.5 unless otherwise specified. Nuts shall be hexagonal, either recessed or with a washer of suitable thickness. Ribbed bolts shall make a driving fit with the holes. The hardness of the ribs shall be such that the ribs do not mash down enough to permit the bolts to turn in the holes during tightening. If for any reason the bolt twists before drawing tight, the hole shall be carefully reamed and an oversized bolt used as a replacement.

**S-810.02.21--Connections Using High Strength Bolts.** This subsection covers the assembly of structural joints using ASTM Designation: A 325 high strength bolts for structural steel joints or ASTM Designation: A 490 quenched and tempered alloy bolts for structural steel joints, or equivalent fasteners, tightened to a high tension. The bolts are used in holes conforming to the requirements of S-810.02.8, S-810.02.9 and S-810.02.10.

**S-810.02.21.1 --Bolts, Nuts, Washers and Direct Tension Indicators (DTI).** All bolts, nuts, washers and DTI shall conform to the requirements of S-717 for such items.

Unless otherwise shown on the plans, all threaded bolts shall be of sufficient length to provide at least full-thread engagement, as defined in S-810.04.4, immediately prior to final tensioning.

All markings on bolts, nuts, washers and direct tension indicators must include the symbol of the Manufacturer and not the Distributor or any other trading entity. This is spelled out in all ASTM specifications covering these product categories. A325 bolts shall be marked "A325" and A490 bolts marked "A490". Type 1 A325 bolts shall be marked with three radial lines 120° apart. Type 3 A325 bolts shall have A325 underlined plus other distinguishing marks indicating that the bolt is atmospheric corrosion resistant and of a weathering type. Type 2 A325 bolts shall be marked with three radial lines 60° apart. Direct tension indicators shall also be marked "325" in the case of Type "325" or "490".

**S-810.02.21.2--Bolted Parts.** The slope of surfaces of bolted parts in contact with the bolt head and nut shall not exceed 1:20 with respect to a plane normal to the bolt axis. Bolted parts shall fit solidly together when assembled and shall not be separated by gaskets or any other interposed compressible material.

When assembled, all joint surfaces, including those adjacent to the bolt heads, nuts, or washers, shall be free of scale, except tight mill scale, and shall also be free of dirt, loose scale, burrs, other foreign material, and other defects that would prevent solid seating of the parts. Paint is permitted in bearing-type connections.

Contact surfaces within friction-type joints shall be free of oil, paint, lacquer or other coatings, except as listed below:

- A. Hot dip galvanizing, if contact surfaces are scored by wire brushing or blasting after galvanizing and prior to assembly. The wire brushing treatment shall be a light application of manual brushing, not power wire brushing, that marks or scores the surface but removes relatively little of the zinc coating. The blasting treatment shall be a light "brush-off" treatment which will produce a dull gray appearance. However, neither treatment should be severe enough to produce any break or discontinuity in the zinc surface.

- B. Inorganic zinc rich paints as specified in S-710.04.

ASTM A 325 Type 2 and ASTM A 490 bolts shall not be galvanized nor shall they be used to connect galvanized material.

**S-810.03--Construction Requirements.**

**S-810.03.1--Installation.**

**S-810.03.1.1--Bolt Tension.** Each fastener shall be tightened to provide, when all fasteners in the joint are tight, at least the minimum bolt tension for the size and grade of fastener used, as shown in the following table:

<b>MINIMUM BOLT TENSION</b>		
<b>BOLT SIZE</b>	<b>ASTM A 325 BOLTS</b>	<b>ASTM A 490 BOLTS</b>
<b>(inches)</b>	<b>(pounds)</b>	<b>(pounds)</b>
1/2	12,050	14,900
5/8	19,200	23,700
3/4	28,400	35,100
7/8	39,250	48,500
1	51,500	63,600
1 1/8	56,450	80,100
1 1/4	71,700	101,800
1 3/8	85,450	121,300
1 1/2	104,000	147,500

The rotational-capacity test described in S-717.02.3.4 shall be performed on each rotational-capacity lot prior to the start of bolt installation. Hardened steel washers are required as part of the test although they may not be required in the actual installation procedure.

A Skidmore-Wilhelm Calibrator or an equivalent tension measuring device shall be required at each job sit during erection. Periodic testing (at least one each working day when the calibrated wrench method is used) shall be performed to assure compliance with the installation requirements for calibrated wrench tightening, turn-of-nut tightening or direct tension indicators (DTI) tightening.

The Contractor shall provide all wrenches necessary for obtaining the specified bolt tension, and shall also provide at his expense the necessary inspection wrenches and provisions for calibration of such wrenches as specified in this subsection and in S-810.03.2.

Threaded bolts shall be checked for tension with properly calibrated wrenches, by the turn-of-nut method, or by the use of Direct Tension Indicators. When required because of bolt entering and wrench operating clearances, tightening may be accomplished by turning the bolt while the nut is prevented from rotating, provided the requirements of S-810.03.1.2 and S-810.03.1.5 are met.

Impact wrenches, if used, shall be of adequate capacity and sufficiently supplied with air to perform the required tightening of each bolt in approximately 10 seconds.

ASTM A490 and galvanized ASTM A325 bolts shall not be reused. Other ASTM A325 bolts may be reused, but not more than once, if approved by the Engineer. Retightening previously tightened bolts which may have been loosened by the tightening of adjacent bolts shall not be considered as a reuse.

Galvanized nuts shall be checked to verify that a visible lubricant is on the threads. Black bolts shall be "oily" to the touch when delivered and installed. Weathered or rusted bolts and nuts shall be cleaned and relubricated prior to installation. Bolt, nut and washer combinations as installed shall be from the same rotational-capacity lot, reference S-717.02.

**S-810.03.1.2--Washers.** All fasteners shall have a hardened washer under the element (nut or bolt head) turned in tightening except that ASTM A325 bolts installed by the turn of the nut method in holes which are not oversize or slotted may have the washer omitted. Hardened washers shall be used under both the head and nut regardless of the element turned in the case of ASTM A490 bolts if the material against which it bears has a specified yield strength less than 40 ksi. When ASTM A 490 bolts over one inch in diameter are used in conjunction with short slotted or oversized holes, the hardened washers shall be at least 5/16 inch thick.

Where an outer face of the bolted parts has a slope of more than 1:20 with respect to a plane normal to the bolt axis, a smooth beveled washer shall be used to compensate for the lack of parallelism.

**S-810.03.1.3--Calibrated Wrench Tightening.** When calibrated wrenches are used to provide the bolt tension specified in S-810.03.1.1, their setting shall be such as to induce a bolt tension 5 percent to 10 percent in excess of this value. These wrenches shall be calibrated at least once each working day by tightening, in a device capable of indicating actual bolt tension, not less than three typical bolts of each diameter to be installed. Power wrenches shall be adjusted to stall or cut-out at the selected tension. If manual force wrenches are used, the force indication corresponding to the calibrating tension shall be noted and used in the installation of all bolts of the tested lot. Nuts shall be in tightening motion when torque is measured. When using calibrated wrenches to install several bolts in a single joint, the wrench shall be returned to "touch up" bolts previously tightened, which may have been loosened by the tightening of subsequent bolts, until all are tightened to the specified tension.

The required torque for calibrated wrenches may be approximated by the following formula:  
 $T(\text{inch-pounds}) = 0.2 \times \text{Bolt Diameter (inches)} \times \text{Bolt Tension (pounds)}$

**S-810.03.1.4--Turn-of-Nut Tightening.** When the turn-of-nut method is used to provide the bolt tension specified in S-810.03.1.1, there shall first be enough bolts brought to a "snug tight" condition to insure that the parts of the joint are brought into full contact with each other. "Snug tight" is defined as the initial tightening of the nut such that a load in the bolt of not less than 10% of the specified proof load for each type and size bolt used is produced. Following this initial operation, bolts shall be placed in the remaining holes in the connection and brought to snug tightness. All bolts in the joint shall then be tightened additionally by the applicable nut rotation specified in the following table with tightening progressing systematically from the most rigid part of the joint to its free edges. During this operation there shall be no rotation of the part not turned by the wrench.

**NUT ROTATION <sup>(1)</sup> FROM SNUG-TIGHT CONDITION**

(For coarse thread heavy hexagon structural bolts of all sizes and lengths and heavy hexagon semi-finished nuts)

Bolt Length (as measured from underside of head to extreme end of point)	Disposition of Outer Faces of Bolted Parts		
	Both faces normal to bolt axis	One face normal to bolt axis and other face sloped not more than 1:20 (bevel washer not used)	Both faces sloped not more than 1:20 from normal to bolt axis (bevel washer not used)
Up to and including 4 diameters	1/3 turn*	1/2 turn*	2/3 turn**
Over 4 diameters but not exceeding 8 diameters	1/2 turn*	2/3 turn**	5/6 turn**
Over 8 diameters but not exceeding 12 diameters	2/3 turn**	5/6 turn**	1 turn**

(1) Nut rotation is rotation relative to bolt regardless of the element (nut or bolt) being turned.

\* Rotation Tolerance: Plus or minus 30 degrees

\*\*Rotation Tolerance: Plus or minus 45 degrees

**S-810.03.1.5--Direct Tension Indicators (DTI) Tightening.** When DTI are required on the plans, the Contractor shall furnish a copy of the manufacturer's written installation instructions to the Engineer for approval prior to beginning work.

It shall be the Contractor's responsibility to have a manufacturer's representative on the job site during initial installation of bolt connections to instruct personnel on the correct method of installation and inspection of the DTI.

The DTI shall be installed and the bolts tightened in strict accordance with the manufacturer's written instructions. The DTI are in addition to washers required by the plans and Standard Specifications.



DTI protrusions for all installations shall bear against a hardened unturned surface, normally either the underside of the bolt head or a hardened washer, and never directly against the turned element.

Prior to the final tightening of all high strength bolts, all the plies of steel shall be drawn together by partially compressing DTI protrusions to ensure "snug tight" conditions. The final tightening shall progress systematically from the most rigid part of the joint to its free edges until the DTI on all bolts are closed to 0.005 inch.

DTI shall not be reused. If it becomes necessary to loosen a bolt previously tensioned, the DTI shall be discarded and replaced.

Bolts shall be of sufficient length to accommodate an indicator and washers made necessary by its use.

The Contractor shall furnish a Skidmore-Wilhelm device or approved equal capable of measuring actual bolt tension. At least three typical bolts and direct tension indicators shall be tightened in a device capable of determining their performance characteristics prior to the start of bolt placement. The device shall be made available thereafter during bolt placement for similar checks not to exceed intervals of one week unless directed otherwise by the Engineer.

High strength bolts, nuts, washers, and direct tension indicators shall be shipped to the project site in sealed metal containers or an approved equal. They shall be stored out of the weather in a location approved by the Engineer. The containers shall remain unopened until the contents are needed for erection. Bolts which, before use, have been exposed and become dried out or rusty will be rejected and will not be used until they are cleaned and lubricated.

**S-810.03.1.6--Lock-Pin and Collar Fasteners.** The installation of lock-pin and collar fasteners shall be by methods and procedures approved by the Engineer.

**S-810.03.2--Inspection.** The Engineer will observe the installation and tightening of bolts to determine that the selected tightening procedure is properly used and will determine that all bolts are tightened. When the calibrated wrench method of tightening is used, the Engineer will have full opportunity to witness the calibration tests prescribed in S-810.03.1.3.

The following inspection shall be used unless a more extensive or different inspection procedure is specified.

**S-810.03.2.1.** Either the Engineer, or the Contractor in the presence of the Engineer, shall use an inspecting wrench which may be either a torque wrench or a power wrench that can be accurately adjusted in accordance with the requirements of S-810.03.1.3.

**S-810.03.2.2** Three bolts of the same grade, size (length may be any length representative of bolts used in the structure) and conditions as those under inspection shall be placed individually in a calibration device capable of indicating bolt tension. There shall be a washer under the part turned in tightening each bolt.

**S-810.03.2.3.** When the inspecting wrench is a torque wrench, each bolt specified in S-810.03.2.2 shall be tightened in the calibration device by any convenient means to the minimum tension specified for its size in S-810.03.1.1. The inspecting wrench then shall be applied to the tightened bolt and the torque necessary to turn the nut or head five degrees (approximately one inch at 12 inch radius) in the tightening direction shall be determined. The average torque measured in the tests of three bolts shall be taken as the job inspecting torque to be used in the manner specified in S-810.03.2.5.

**S-810.03.2.4.** When the inspecting wrench is a torque wrench it shall be adjusted so that it will tighten each bolt specified in S-810.03.2.2 to a tension at least 5 but not more than 10 percent greater than the minimum tension specified for its size in S-810.03.1.1. This setting of wrench shall be taken as the job inspecting torque to be used in the manner specified in the following paragraph.

**S-810.03.2.5.** Bolts represented by the sample prescribed in S-810.03.2.2 which have been tightened in the structure shall be inspected by applying, in the tightening direction, the inspecting wrench and its job inspecting torque to 10 percent of the bolts, but not less than two bolts, selected at random in each connection. If no nut or bolt head is turned by this application of the job inspecting torque, the connection shall be accepted as properly tightened. If any nut or bolt head is turned by the application of the job inspecting torque, this torque shall be applied to all bolts in the connection, and all bolts whose nut or head is turned by the job inspecting torque shall be tightened and re-inspected, or alternatively, the fabricator or erector, at no additional cost to the Project, may re-tighten all of the bolts in the connection in the manner required and subject to the limitations imposed for the initial tightening and then resubmit the connection for the specified inspection.

**S-810.03.2.6.** When direct tension indicators are used, the Engineer's inspector will check for correct tensioning by inserting a correct-thickness pointed feeler gage into the opening between adjacent flattened protrusions in accordance with the manufacturer's instructions and S-810.03.1.5. At least ten percent, but no less than two, of the bolts in each connection will be examined.

A nil gap on ASTM A325 bolts is not cause for rejection. A nil gap for ASTM A490 bolts is not allowed.

**S-810.03.2.7.** The procedures for inspecting and testing the lock-pin and collar fasteners and their installation to insure that the required pre-load tension is provided shall be as approved by the Engineer.

**S-810.03.3--Blank.**

**S-810.03.4--Plate Cut Edges.**

**S-810.03.4.1--Edge Planing.** Sheared edges of plates more than 5/8 inch in thickness and carrying calculated stress shall be planed to a depth of 1/4 inch. Re-entrant cuts shall be filleted to a minimum radius of 3/4 inch before cutting.

**S-810.03.4.2--Visual Inspection and Repair of Plate Cut Edges.** Visual inspection and repair of plate cut edges shall be in accordance with the Welding Code.

**S-810.03.5--Welds.** Welding of steel structures, when authorized on the plans or on approved working drawings, and pre-qualification of welding operators shall conform to the Welding Code, current at the time of advertisement for bids.

Welding shall be tested by non-destructive methods as prescribed in the noted Welding Code and as indicated on the plans. Edge blocks shall be used when radiographing butt welds greater than 1/2 inch thickness. The edge blocks shall have a length sufficient to extend beyond each side of the weld centerline for a minimum distance equal to the weld thickness, but no less than 2 inches, and shall have a thickness equal to or greater than the thickness of the weld. The minimum width of the edge blocks shall be equal to half the weld thickness, but not less than 1 inch. The edge blocks shall be centered on the weld with a snug fit against the plate being radiographed, allowing no more than 1/16 inch gap. Edge blocks shall be made of radiographically clean steel and the surface shall have a finish of ANSI 125 μinch, or smoother. Non-destructive testing shall be performed at the expense of the Contractor.

**S-810.03.6--Oxygen Cutting.** All oxygen cutting shall conform to the Welding Code.

**S-810.03.7--Facing of Bearing Surfaces.** The surface finish of bearing and base plates and other bearing surfaces that are to come in contact with each other or with concrete shall meet the ANSI surface roughness requirements as defined in ANSI B 46.1, Surface Roughness, Waviness, and Lay, Part 1:

Steel Slabs	ANSI	2,000
Heavy plates in contact in shoes to be welded	ANSI	1,000
Milled ends and compression members, milled or ground ends of stiffeners, and fillers	ANSI	500
Bridge rollers and rockers	ANSI	250
Pins and pin holes	ANSI	125
Sliding bearings	ANSI	125

**S-810.03.8--Abutting Joints.** Abutting joints in compression members and girder flanges, and in tension members where so specified on the drawings, shall be faced and brought to an even bearing. Where joints are not faced, the opening shall not exceed 1/4 inch.

**S-810.03.9--End Connection Angles.** Floorbeams, stringers and girders having end connection angles shall be built to the exact length shown on the plans measured between the heels of the connection angles, with a permissible tolerance of 0 inch to minus 1/16 inch. Where continuity is to be required, end connections shall be faced. The thickness of the connection angles shall not be less than 3/8 inch or that shown on the detail drawings.

**S-810.03.10--Lacing Bars.** The ends of lacing bars shall be neatly rounded unless another form is required.

**S-810.03.11--Fabrication of Members.** Unless otherwise shown on the plans, steel plates for main members, not secondary members, shall be cut and fabricated so that the primary direction of rolling is parallel to the direction of the main tensile and/or compressive stresses.

Fabricated members shall be true to line and free from twists, bends and open joints.

**S-810.03.12--Web Plates.** In girders having no cover plates and not to be encased in concrete, the top edge of the web plate shall not extend above the backs of the flange angles and shall not be more than 1/8 inch below at any point. Any portion of the plate projecting beyond the angles shall be chipped flush with the backs of the angles. Web plates of girders having cover plates may be 1/2 inch less in width than the distance back to back of flange angles.

Splices in webs of girders without cover plates shall be sealed on the top with red lead paste prior to painting.

At web splices, the clearance between the end of the web plates shall not exceed 3/8 inch. The clearance at the top and bottom ends of the web splice plates shall not exceed 1/4 inch.

**S-810.03.13--Bent Plates.** Unwelded, cold-bent, load-carrying, rolled-steel plates shall conform to the following:

- (a) They shall be so taken from the stock plates that the bend line will be at right angles to the direction of rolling, except that cold-bent ribs for orthotopic deck bridges may be bent in the direction of rolling if permitted by the Engineer.
- (b) Bending shall be such that no cracking of the plate occurs. Minimum bend radii, measured to the concave face of the metal, are shown in the following table:

Thickness(t) in inches	Up to 1/2	Over 1/2 to 1	Over 1 to 1 1/2	Over 1 1/2 to 2 1/2	Over 2 1/2 to 4
Minimum Bend Radii	2 t	2 1/2 t	3 t	3 1/2 t	4 t
All grades of steel					

Note: Low alloy steel in thickness over 1/2 inch may require hot bending for small radii.

Allowance for springback of ASTM A514 and A517 steels should be about three times that for structural carbon steel. For brake press forming, the lower die span should be at least 16 times the plate thickness. Multiple hits are advisable.

If a shorter radius is essential, the plates shall be bent hot at a temperature not greater than 1200° F, except for ASTM A514/A517 steel. If ASTM A514/A517 steel plates to be bent are heated to a temperature greater than 1125°F, they must be requenched and tempered in accordance with the producing mill's practice. Hot bent plates shall conform to requirement (a).

- (c) Before bending, the corners of the plate shall be rounded to a radius of 1/16 inch throughout the portion of the plate at which the bending is to occur.

**S-810.03.14--Fit of Stiffeners.** End stiffeners of girders and stiffeners intended as supports for concentrated loads shall have full bearing (either milled, ground, or, on weldable steel in compression areas of flanges, welded as shown on the plans or specified) on the flanges to which they transmit load or from which they receive load.

Stiffeners not intended to support concentrated loads shall, unless shown or specified otherwise, fit sufficiently tight to exclude water after being painted. Fillers under stiffeners shall fit within 1/4 inch at each end.

**S-810.03.15--Eyebars.** Pin holes may be flame cut at least two inches smaller in diameter than the finished pin diameter. All eyebars that are to be placed side by side in the structure shall be securely fastened together in the order that they will be placed on the pin and bored at both ends while so clamped. Eyebars shall be packed and match marked for shipment and erection. All identifying marks shall be stamped with steel stencils on the edge of one head of each member after fabrication is completed so as to be visible when the bars are nested in place on the structure. The eyebars shall be straight and free from twists and the pin holes shall be accurately located on the centerline of the bar.

The inclination of any bar to the plane of the truss shall not exceed 1/16 inch to a foot. The edges of eyebars that lie between the transverse centerline of their pin holes shall be cut simultaneously with two mechanically operated torches abreast of each other, guided by a substantial template, in such a manner as to prevent distortion of the plates.

**S-810.03.16--Annealing and Stress Relieving.** Structural members which are indicated to be annealed or normalized shall have finished machining, boring, and straightening done subsequent to heat treatment. Normalizing and annealing (full annealing) shall be as specified in ASTM Designation: E 44. The temperatures shall be maintained uniformly throughout the furnace during the heating and cooling so that the temperature at no two points on the member will differ by more than 100°F at any one time.

Members of ASTM A514/A517 steels shall not be annealed or normalized and shall be stress relieved only with the approval of the Engineer.

A record of each furnace charge shall identify the pieces in the charge and show the temperatures and schedule actually used.

Proper instruments, including recording pyrometers, shall be provided for determining at any time the temperatures of members in the furnace. The records of the treatment operation shall be available to and meet the approval of the Engineer. The holding temperature for stress relieving ASTM A514/A517 steel shall not exceed 1125°F.

Members, such as bridge shoes, pedestals, or other parts which are built up by welding sections of plate together shall be stress relieved in accordance with the procedure of the Welding Code.

**S-810.03.17--Pins and Rollers.** Pins and rollers shall be accurately turned to the dimensions shown on the drawings and shall be straight, smooth, and free from flaws. Pins and rollers more than nine inches in diameter shall be forged and annealed. Pins and rollers nine inches or less in diameter may be either forged and annealed or cold-finished carbon-steel shafting.

In pins larger than nine inches in diameter, a hole not less than two inches in diameter shall be bored full length along the axis after the forging has been allowed to cool to a temperature below the critical range under suitable conditions to prevent injury by too rapid cooling and before being annealed.

**S-810.03.18--Boring Pin Holes.** Pin holes shall be bored true to the specified diameter, smooth, and straight, at right angles with the axis of the member, and parallel with each other unless otherwise required. The final surface shall be produced by a finishing cut.

The distance outside to outside of end holes in tension members and inside to inside of end holes in compression members shall not vary from that specified by more than 0.031 inch. Boring of holes in built-up members shall be done after the bolting is complete.

**S-810.03.19--Pin Clearances.** The diameter of the pin hole shall not exceed that of the pin by more than 0.020 inch for pins five inches or less in diameter or 0.031 inch for larger pins.

**S-810.03.20--Threads for Bolts and Pins.** Threads for all bolts and pins for structural steel construction shall conform to the Unified Standard Series UNC-ANSI B1.1, Class 2A for external threads and Class 2B for internal threads, except that pin ends having a diameter of 1 3/8 inches or more shall be threaded six threads to the inch.

**S-810.03.21--Pilot and Driving Nuts.** Two pilot nuts and two driving nuts for each size of pin shall be furnished, unless otherwise specified.

**S-810.03.22--Notice of Beginning Work.** The Contractor shall give the Engineer ample notice of the beginning of work at the mill or in the shop so that inspection may be provided. The term "mill" means any rolling mill or foundry where material for the work is to be manufactured. No material shall be manufactured or work done in the shop before the Engineer has been so notified.

Prior to any fabrication, the fabricator shall have on hand Shop Drawings, Weld Procedures and a procedure for storage and handling of welding electrodes, wire and flux which have been approved by the Engineer with concurrence of the State Aid Bridge Engineer. No fabrication shall begin until a prefabrication conference has been held and the facilities have been inspected and approved by the Engineer.

When ordering structural steel, the fabricator shall specify the current ASTM designation for the material based on the date of advertisement for bids.

**S-810.03.23--Facilities for Inspection.** The Contractor shall furnish facilities for the inspection of material and workmanship in the mill and shop, and the inspectors shall be allowed free access to the necessary parts of the works.

Inspection at the mill and shop is intended as a means of facilitating the work and avoiding errors, and it is expressly understood that it will not relieve the Contractor from any responsibility in regard to imperfect material or workmanship and the necessity for replacing same.

**S-810.03.24--Inspector's Authority.** Inspectors shall have the authority to reject any material or work which does not meet the requirements of these specifications. In case of dispute, the Contractor may appeal to the Engineer, whose decision with the concurrence of the State Aid Engineer shall be final.

The acceptance of any material or finished members by the inspector shall not be a bar to their subsequent rejection, if found defective. Rejected material and workmanship shall be replaced promptly or made good by the Contractor.

Material and workmanship not previously inspected shall be inspected after its delivery to the site of the work.



**S-810.03.25--Working Drawings and Identification of Steel During Fabrication.**

**S-810.03.25.1--Working Drawings.** Shop drawings and other required drawings shall be submitted to the Engineer for approval with concurrence of the State Aid Bridge Engineer and subject to the provisions of S-810.02.2.

Shop drawings for steel structures shall give full detailed dimensions and sizes of component parts of the structure and details of all miscellaneous parts such as pins, nuts, bolts, drains, etc.

The Contractor shall expressly understand that the Engineer's approval of the working drawings cover the requirements for "strength and detail", and the Engineer assumes no responsibility for errors in dimensions.

**S-810.03.25.2--Identification of Steels During Fabrication.**

**S-810.03.25.2.1--Identification by Contractor.** The Engineer shall be furnished with two complete copies of certified mill test reports showing chemical analysis and heat of steel for all members unless excepted by Engineer. Each piece of steel to be fabricated shall be properly identified for the Engineer.

Shop drawings shall specifically identify each piece that is to be made of steel other than ASTM A 36. Pieces made of different grades of steel shall not be given the same assembling or erecting mark, even though they are of identical dimensions and detail.

The Contractor's system of assembly-marking individual pieces, required to be made of steel other than ASTM A 36, and the issuance of cutting instructions to the shop (generally by cross referencing of the assembly-marks shown on the shop drawings with the corresponding item covered on the mill purchase order) shall be such as to maintain identify of the mill test report number.

The Contractor may furnish from stock, material that he can identify by heat number and mill test report.

All excess material placed in stock for later use shall be marked with the mill test report number and shall be marked with its ASTM A 6 specification identification color code (see table below) if any, when separated from the full-size pieces furnished by the supplier.

**S-810.03.25.2.2--Identification of Steels During Fabrication.** During fabrication, up to the point of assembling members, each piece of steel, other than ASTM A 36, shall show clearly and legibly its specification identification color code shown in table below.

Individual marked pieces of steel which are used in furnished size, or reduced from furnished size only by end or edge trim, that does not disturb the heat number or color code or leave any usable piece may be used without further color coding provided that the heat number or color code remains legible.

Pieces of steel, other than ASTM A 36, which are to be cut to smaller size pieces shall, before cutting, be legibly marked with the ASTM A 6 specification identification color code.

Individual pieces of steel, other than ASTM A 36, which are furnished in tagged lifts or bundles shall be marked with the ASTM A 6 specification identification color code immediately upon being removed from the bundle or lift.

Pieces of steel, other than ASTM A 36, which, prior to assembling into members, will be subject to fabricating operations such as blast cleaning, galvanizing, heating for forming, or painting which might obliterate paint color code marking shall be marked for grade by steel die stamping or by a substantial tag firmly attached.

The following identification color code shall be used to identify material required to meet the individual specifications listed in table below.

#### **IDENTIFICATION COLOR CODES**

ASTM A 36	White
ASTM A 514	Red
ASTM A 517	Red and Blue
ASTM A 572, Grade 50	Green and Yellow
ASTM A 588	Blue and Yellow
ASTM A 852	Blue and Orange

Other steels, except ASTM A 36, not covered above nor included in the ASTM A 6 Specification, shall have an individual color code which shall be established and on record for the Engineer.

**S-810.03.25.2.3--Certification of Identification.** Upon request, the Contractor shall furnish an affidavit certifying that throughout the fabrication operation he has maintained the identification of steel in accordance with this specification.

**S-810.03.26--Full Size Tests.** When full size tests of fabricated structural members or eyebars are required, the plans or specifications will state the number and the nature of the tests, the results to be attained, and the measurements of strength, deformation, or other performance that are to be made. The Contractor shall provide suitable facilities, material, supervision, and labor necessary for making and recording the tests. The members tested in accordance with the contract will be measured for payment in accordance with S-810.04.

The cost of testing including equipment, handling, supervision, labor, and incidentals for making the test shall be included in the contract price for the fabrication or fabrication and erection of structural steel, whichever is the applicable item in the contract, unless otherwise specified.

**S-810.03.27--Marking and Shipping.** Each member shall be painted or marked with an erection mark for identification, and an erection diagram shall be furnished with erection marks shown thereon.

The Contractor shall furnish to the Engineer as many copies of material orders, shipping statements, and erection diagrams as requested. The weights of the individual members shall be shown on the statements. Members weighing more than three tons shall have the weights marked thereon. Structural members shall be loaded on trucks or cars in such a manner that they may be transported and unloaded at their destination without being excessively stressed, deformed, or otherwise damaged.

Bolts of one length and diameter and loose nuts or washers of each size shall be packed separately. Pins, small parts, and packages of bolts, washers, and nuts shall be shipped in boxes, crates, kegs, or barrels, but the gross weight of any package shall not exceed 300 pounds. A list and description of the contained material shall be plainly marked on the outside of each shipping container.

When Direct Tension Indicators are required on plans, the bolts, nuts, washers and DTI shall be shipped and stored in accordance with Subsection 810.03.1.5.

### **ERECTION**

**S-810.03.28--Erection of Structure.** The Contractor shall erect the metal work, remove the temporary construction, and do all work required to complete the bridge or bridges as covered by the contract, including the removal of the old structure if stipulated, all in accordance with the plans and these specifications.

**S-810.03.28.1--Plans.** If the fabrication and erection of the superstructure are done under separate contracts, the County will furnish detail plans for the bridge or bridges to be erected, including shop details, camber diagrams, erection diagrams, list of bolts, and copy of shipping statements showing a list of parts and their weights.

**S-810.03.28.2--Plant.** The Contractor shall provide the falsework and all tools, machinery, and appliances, including drift pins and fitting-up bolts necessary for the expeditious prosecution of the work.

**S-810.03.28.3--Delivery of Material.** If the contract is for erection only, the Contractor shall receive the materials entering into the finished structure, free of charge at the place designated and loaded or unloaded as specified. The Contractor shall unload promptly upon delivery all materials delivered on railroad cars or barges which he is required to unload, otherwise he shall be responsible for demurrage charges.

**S-810.03.28.4--Handling and Storing Materials.** Material to be stored shall be placed on skids above the ground. It shall be kept clean and properly drained. Girders and beams shall be placed upright and shored. Long members, such as columns and chords, shall be supported on skids placed near enough together to prevent injury from deflection. If the contract is for erection only, the Contractor shall check the material turned over to him against the shipping lists and report promptly in writing all shortages or injuries discovered. He shall be responsible for the loss of any material while in his care and for all damage caused to it after being received by him.

**S-810.03.28.5--Falsework.** The falsework shall be properly designed and substantially constructed and maintained for the loads which will come upon it. The Contractor, if required, shall prepare and submit to the Engineer for approval, plans for falsework or for changes in an existing structure necessary for maintaining traffic. Approval of the Contractor's plans shall not be considered as relieving the Contractor of any responsibility.

**S-810.03.28.6--Methods and Equipment.** Before starting erection, the Contractor shall inform the Engineer fully as to the method of erection he proposes to follow and the amount and character of equipment he proposes to use, which shall be subject to the approval of the Engineer. The approval of the Engineer shall not be considered as relieving the Contractor of the responsibility for the safety of his method or equipment or from carrying out the work in full accordance with the plans and specifications. No work shall be done until the approval of the Engineer has been obtained.

**S-810.03.28.7--Bearings and Anchorages.** Masonry bearing plates shall not be placed upon bridge seat bearing areas which are improperly finished, deformed, or irregular. Bearing plates shall be set level in exact position and shall have a full and even bearing upon the masonry. Unless otherwise directed by the Engineer, they shall be placed on a layer of sheet lead one-eight inch in thickness.

Elastomeric bearing pads, if used, shall be set directly on the masonry.

The Contractor shall drill the holes and set the anchor bolts, except where the bolts are built into the masonry. The bolts shall be set accurately and fixed with Portland cement grout completely filling the holes.

Location of anchors and setting of rockers or rollers shall take into account the variation from mean temperature at time of setting and anticipated lengthening of bottom chord or bottom flange due to dead load after setting, the intention being that, as near as practicable, at mean temperature and under dead load the rockers and rollers shall set vertical and anchor bolts at expansion bearings will center their slots. Care shall be taken that full and free movement of the superstructure at the movable bearings is not restricted by improper setting or adjustment of bearings or anchor bolt and nuts.

**S-810.03.28.8--Straightening Bent Material.** The straightening of plates, angles, other shapes, and built-up members, when permitted by the Engineer, shall be done by methods that will not produce fracture or other injury. Distorted members shall be straightened by mechanical means or, if approved by the Engineer, by the carefully planned and supervised application of limited localized heat, except that heat straightening of ASTM A514/A517 steel members shall be done only under rigidly controlled procedures, each application subject to the approval of the Engineer. In no case shall the maximum temperature of ASTM A514/A517 steel exceed 1125°F, nor shall the temperature exceed 950°F at the weld metal or within six inches of weld metal. Heat shall not be applied directly on weld metal. In all other steels, the temperature of the heated area shall not exceed 1200°F, a dull red, as controlled by temperature indicating crayons, liquids, or bimetal thermometers.

Parts to be heat straightened shall be substantially free of stress and from external forces, except stresses resulting from mechanical means used in conjunction with the application of heat.

Following the straightening of a bend or buckle, the surface of the metal shall be carefully inspected for evidence of fracture.

**S-810.03.28.9--Cambering.** Correction of errors in camber in welded beams and girders of ASTM A514/A517 material shall be done only under rigidly controlled procedures, each application subject to approval of the Engineer.

**S-810.03.28.10--Assembling Steel.** The parts shall be accurately assembled as shown on the plans and any match-marks shall be followed. The material shall be carefully handled so that no parts will be bent, broken, or otherwise damaged. Hammering which will injure or distort the members shall not be done. Bearing surfaces and surfaces to be in permanent contact shall be cleaned before the members are assembled.

Unless erected by the cantilever method, truss spans shall be erected on blocking so as to give the trusses proper camber. The blocking shall be left in place until the tension chord splices are bolted and all other truss connections pinned and bolted. Permanent bolts in splices of butt joints of compression members and permanent bolts in railings shall not be tightened until the span has been swung. Splices and field connections shall have one half of the holes filled with bolts and cylindrical erection pins (half bolts and half pins) before bolting with high strength bolts. Splices and connections carrying traffic during erection shall have three-fourths of the holes so filled.

**S-810.03.28.11--Blank.**

**S-810.03.28.12--Pin Connections.** Pilot and driving nuts shall be used in driving pins. They shall be furnished by the Contractor without charge. Pins shall be so driven that the members will take full bearing on them. Pin nuts shall be screwed up tight and the threads burred at the face of the nut with a pointed tool.

**S-810.03.28.13--Misfits.** The correction of minor misfits involving harmless amounts of reaming, cutting and chipping will be considered a legitimate part of the erection. However, any error in the shop fabrication or deformation resulting from handling and transportation which prevents the proper assembling and fitting up of parts by the moderate use of drift pins or by a moderate amount of reaming and slight chipping or cutting shall be reported immediately to the Engineer and his approval of the method of correction obtained. The correction shall be made in his presence. If the contract provides for complete fabrication and erection, the Contractor shall be responsible for all misfits, errors, and injury and shall make the necessary corrections and replacements. If the contract is for erection only, the Engineer, with the cooperation of the Contractor, will keep a correct record of labor and materials used, and the Contractor shall render within 30 days an itemized bill for the approval of the Engineer.

**S-810.03.29--Removal of Old Structures and Falsework.** Unless the contract indicates that an old structure is to remain in place, the Contractor shall dismantle and dispose of such structure in accordance with the methods and requirements set out in S-202.

Upon completion of the erection and before final acceptance, the Contractor shall remove all falsework, excess excavation and useless materials. All excavated material or falsework placed in the stream channel during construction shall be removed by the Contractor before final acceptance.

## COMPENSATION

### S-810.04--Method of Measurement.

**S-810.04.1--General.** The steel superstructure will be measured as a lump sum quantity, complete in place. Structural steel will be measured for payment by the pound based on the weight of metal in the fabricated structure as provided in the contract.

Miscellaneous material items such as castings, bearing plates, lead sheets, anchor bolts, and all other metal for which no direct payment is specified and the contract proposal does not include a bid item for miscellaneous bridge appurtenances will be included in the measurement for structural steel except when the plans and specifications provide that payment will not be allowed for certain materials. When direct tension indicators are not required by the contract and the Contractor elects to use such indicators, no measure for payment will be allowed.

**S-810.04.2--Miscellaneous Bridge Appurtenances.** When the bid schedule of the contract contains a pay item for Miscellaneous Bridge Appurtenances, measurement will not be made of individual miscellaneous items, but all will be included in a single lump sum quantity, including all miscellaneous metals and other miscellaneous materials and work not specified to be measured for payment under or to be included in other items of work.

### S-810.04.3--Payment of Weights.

Weight of metals to be paid for shall be based on computed weight.

The weight of erection bolts, high strength bolts, paint, and all boxes, crates, or other containers used for packing, together with sills, struts, and rods used for supporting members during transportation will be excluded. All metals not to remain in the completed structure will not be computed for payment.

Where increases in size or weight of members have been made which were not ordered by the Engineer, but approved by him, measurement will be made on the size or weight indicated on the plans.

Full size members which are tested as required under S-810.03.26 and meet the requirements of these specifications will be measured for payment at the same rate as for the structure.

**S-810.04.4--Computation of Weight.**

The weight of metals specified to be paid for by weight will be computed for payment from the following table:

<u>Metal</u>	<u>Weight</u> <u>Lbs. Per Cu. Ft.</u>
Aluminum, cast or wrought .....	173.0
Bronze, cast .....	536.0
Copper-alloy .....	536.0
Copper sheet .....	558.0
Iron, cast .....	445.0
Iron, malleable .....	470.0
Iron, wrought .....	487.0
Lead, sheet .....	707.0
Steel, rolled, cast, copper bearing, silicon, nickel and stainless .....	490.0
Zinc .....	450.0

The weight of rolled shapes and of plates shall be computed on the basis of their nominal weight and dimensions, as shown on the approved plans and shop drawings, deducting for copes, cuts and open holes.

The weight of castings may be computed from the dimensions shown on the plans, with an addition of five percent for fillets and over-runs, or weighed on approved scales.

No allowance will be made for the weight of paint.



The weight of heads, nuts, single washers, DTIs when required and "threaded stick-through" of all high tensile strength shop bolts will be included on the basis of the following weights:

Diameter of Bolt Inches	Weight per 100 Bolts, Pounds
1/2	19.7
5/8	31.7
3/4	52.4
7/8	80.4
1	116.7
1 1/8	165.1
1 1/4	212.0
1 3/8	280.0
1 1/2	340.0

It shall be understood that the weight of the "threaded stick-through" of the bolts will be on the basis of full-thread engagement. Full-thread engagement is defined as being accomplished when the end of the bolt is flush with the outer face of the nut. The Contractor may at his discretion furnish and use the next longer standard length of bolt than that necessary to accomplish full-threaded engagement, at no additional cost to the Project.

**S-810.04.5--Deduction for Fabrication Inspection Cost Overruns.** Under separate agreement, the Engineer will contract with a private company to provide inspection services for structural steel fabrication. By this agreement a maximum amount payable, including a fixed fee will be established beyond which no funds will be authorized for payment without a Supplemental Agreement.

The structural steel fabrication inspection costs, not to exceed the established maximum amount payable including the fixed fee and any additional amount authorized for payment by Supplemental Agreement, will be paid for from the Project Fund.

Structural steel fabrication inspection costs exceeding the above described amount will be deducted from monies due the Contractor under pay items S-810-A, S-810-B, and/or S-810-C, as the case may be.

Ninety percent (90%) of the amount bid for structural steel items listed above will be the maximum amount paid the Contractor until such time final fabrication inspection costs have been determined and

the Engineer notifies the State Aid Engineer to release full payment to the Contractor; otherwise, the Engineer will advise the State Aid Engineer of the amount to withhold from the Contractor's estimate to cover structural steel fabrication inspection costs that exceed the amount approved for payment by the Engineer.

**S-810.05--Basis of Payment.** Structural steel, subject to the deductions set out in S-810.04.5, will be paid for at the contract unit price per pound. Steel superstructure and miscellaneous bridge appurtenances when shown as a pay item will be paid for at the contract lump sum price. The prices thus paid shall be full compensation for completing the work.

Payment will be made under:

- |   |             |
|---|-------------|
| <b><u>S-810-A:</u></b> Structural Steel *                 | - per pound |
| <b><u>S-810-B:</u></b> Steel Superstructure               | - lump sum  |
| <b><u>S-810-C:</u></b> Miscellaneous Bridge Appurtenances | - lump sum  |

\* Specify the type if other than A 36

**SECTION S-811 - BRONZE OR COPPER-ALLOY  
BEARING AND EXPANSION PLATES**

**S-811.01--Description.** This work shall consist of furnishing and installing metal plates of the kind and type specified and in the manner shown on the plans.

**S-811.02--Materials.** Bearing and expansion plates, of the type and kind specified shall meet the requirements of S-716.06, S-716.07 or S-716.08 as applicable.

**S-811.02.1--Bronze Plates.** Plates shall be cast according to details shown on the plans. Sliding surfaces shall be planed parallel to the movement of the spans and polished unless detailed otherwise.

**S-811.02.2--Copper-Alloy Plates.** Plates shall be furnished according to details shown on the plans. Finishing of the rolled plates will not be required provided they have a plane, true, and smooth surface.

**S-811.03--Construction Requirements.** Bearing plates shall be accurately set in correct position as shown on the plans and shall have a uniform bearing over the whole area. Provision shall be made to keep the plates in correct position as the concrete is being placed.

**COMPENSATION**

**S-811.04--Method of Measurement.** Accepted bearing and expansion plates will be measured by the pound of the type and kind specified. Unless otherwise provided, the measurements will be the Inspector's certified shop scale weight of plates placed in the structure. If specified in the contract, measurement will be computed weight, obtained by methods shown on the plans.

Lubricants will not be measured for separate payment.

**S-811.05--Basis of Payment.** This work will be paid for at the contract unit price per pound, which shall be full compensation for completing the work specified.

Payment will be made under:

- S-811-A:** Bronze Plates - per pound
- S-811-B:** Copper-Alloy Plates - per pound
- S-811-C:** Self-Lubricating \_\_\_\_\_ Plates - per pound  
(Type)

## **SECTION S-812 - STEEL GRID FLOORING**

**S-812.01--Description.** This work shall consist of constructing steel grid flooring, open or concrete-filled type as specified, in accordance with these specifications and in reasonably close conformity to the lines and grades shown on the plans or established.

**S-812.02--Materials.** Materials used shall conform to the provisions of S-717.05.

**S-812.02.1--Arrangement of Sections.** Where the main elements are normal to centerline of roadway, the units generally shall be of such length as to extend over the full width of the roadway up to 40 feet, but in every case the units shall extend over at least three panels. Where joints are required, the ends of the main floor members shall be welded at the joints over their full cross-sectional area or otherwise connected to provide full continuity.

Where the main elements are parallel to centerline of roadway, the sections shall extend over at least three panels, and the ends of abutting units shall be welded over their full cross-sectional area or otherwise connected to provide full continuity in accordance with the design.

**S-812.02.2--Provisions for Camber.** Unless otherwise provided on the plans, provision for camber shall be made as follows:

Steel units so rigid that they will not readily follow the camber required shall be cambered in the shop. To provide a bearing surface parallel to the crown of the roadway the stringers shall be canted or provided with shop-welded beveled bearing bars. If beveled bars are used, they shall be placed along the centerline of the stringer flange, in which case the design span length shall be governed by the width of the bearing bar instead of by the width of the stringer flange.

Longitudinal stringers shall be mill cambered or provided with bearing strips so that the completed floor after dead-load deflection will conform to the longitudinal camber shown on the plans.

**S-812.02.3--Welding.** All shop and field welding shall be in accordance with S-810.03.5.

**S-812.02.4--Repairing Damaged Galvanized Coatings.** All galvanizing that has been chipped off or damaged in handling or transporting or in welding or riveting shall be repaired by field galvanizing by the application of a paste composed of approved zinc powder and flux with a minimum amount of water. The places to be coated shall be thoroughly cleaned, including removal of slag on welds, before the paste is applied. The surface to be coated shall first be heated with a torch to a sufficient temperature so that all metallics in the paste are melted when applied to the heated surface. Extreme care shall be taken to see that the galvanized surfaces are not damaged by the torch. The flux in the paste will cause a black substance to appear on the surface of the coated parts, and this black substance shall be removed by wiping off with waste or by the quick application of cold water.

**S-812.03--Construction Requirements.**

**S-812.03.1--Field Assembly.** Areas of considerable size shall be assembled before the floor is welded to its supports. The main elements shall be made continuous, and sections shall be connected together along their edges by welding of bars or by riveting them. The connections shall meet with the approval of the Engineer. The rivets may be cold driven.

**S-812.03.2--Connection to Supports.** The floor shall be connected to its steel supports by welding. Before any welding is done, the floor shall either be loaded to make a tight joint with full bearing, or it shall be clamped down. The location, length, and size of the welds shall be subject to the approval of the State Aid Engineer, but in no case shall they be less than the manufacturer's standards.

The ends of all the main steel members of the slab shall be securely fastened together at the sides of the roadway for the full length of the span by means of steel plates or angles welded to the ends of the main members, or by thoroughly encasing the ends with concrete.

**S-812.03.3--Concrete Filler.** Floor types with bottom flanges not in contact shall be provided with bottom forms of metal or wood to retain the concrete filler without excessive leakage.

If metal form strips are used they shall fit tightly on the bottom flanges of the floor members and be placed in short lengths so as to extend only about one inch onto the edge of each support, but in all cases the forms shall be such as will result in adequate bearing of slab on the support.

The concrete shall be mixed, placed, and cured in accordance with S-804. The concrete shall be thoroughly compacted by vibrating the steel grid floor. The vibrating device and the manner of operating it shall be subject to the approval of the Engineer.

**S-812.03.4--Painting.** Flooring furnished without galvanizing but with a shop coat of paint shall be given field coats of paint in accordance with S-814.

When a structural steel plate is used on the bottom of a filled type floor, the bottom surface of the plate shall be given one shop coat, one field intermediate coat and one field top coat of paint in accordance with S-814.

**COMPENSATION**

**S-812.04--Method of Measurement.** Accepted steel grid floor will be measured by the square foot. This measurement shall include galvanizing or painting as specified and concrete filling when applicable.

**S-812.05--Basis of Payment.** This work will be paid for at the contract unit price per square foot of the type required, which shall be full compensation for completing the work specified.

Payment will be made under:

**S-812-A:** Steel Grid Floor (Open Type) - per square foot

**S-812-B:** Steel Grid Floor (Concrete Filled Type) - per square foot

## **SECTION S-813 - RAILING**

**S-813.01--General.** This work shall consist of constructing bridge railing of the type specified in accordance with these specifications. Railing for bridges shall include all work constructed above the top of the bridge deck, curb, or sidewalk surface, as applicable. Railing for precast bridges shall conform with S-806.

**S-813.02--Materials.** All materials shall conform to the requirements of S-700 or as specified in the special provisions or on the plans.

Unless otherwise specified, concrete shall be Class "B" meeting the requirements of S-804.

### **S-813.03--Construction Requirements.**

**S-813.03.1--Line and Grade.** Lines and grades of railing shall be in reasonably close conformity to that shown on the plans and shall not follow any unevenness in the superstructure. Unless otherwise specified or shown on the plans, the railing, posts, and curbs on bridges, whether on horizontal grade, superelevated or not, shall be vertical.

### **S-813.03.2--Concrete Railing.**

**S-813.03.2.1--General.** In no case shall concrete railings be placed until the centering or falsework for the span has been released and the span is self-supporting.

**S-813.03.2.2--Railings Cast-In-Place.** The portion of the railing or parapet which is to be cast in place shall be constructed in accordance with the requirements of S-804. Special care shall be exercised to secure smooth and tight-fitting forms which can be rigidly held to line and grade and removed without injury to the concrete.

Steel forms, single width boards or other approved material shall be required for casting concrete railing. Form joints in plane surfaces will not be permitted. The transition section of the rail is to be formed in accordance with the standard and not slip formed.

All moldings, panel work, and bevel strips shall be constructed according to the detail plans with neatly mitered joints, and all corners in the finished work shall be true, sharp, and clean-cut and shall be free from cracks, spalling, or other defects.

**S-813.03.2.2.1--Slip Form Construction.** The slip form method of construction may be used for cast-in-place rail construction with the approval of the Engineer.

If permitted, the equipment shall be self-contained, power propelled units with approved automatic control devices for maintaining both true line and elevation.

The concrete will be of a consistency so that there will be no slump or subsidence after the passage of the forming equipment. It shall be the responsibility of the contractor to obtain a proper mix design for this type of placement prior to starting the work.

Joints will be sawed after the concrete has set and will be truly vertical. The location and width of the joints shall be as shown on the plans. The intermediate joints between the span joints are to be saw cut to a width of approximately 5/16 inch. The saw cut will leave a radius at the bottom on the backside since the 24-inch radius blade will not completely pass over the 32 inch high rail.

The span joints will be double cut to the exact width of the bridge deck span joint.

**S-813.03.2.3--Surface Finish.** The surfaces of concrete railings shall conform to the requirements of S-804.03.19.

**S-813.03.2.4--Expansion Joints.** Expansion joints shall be so constructed as to permit freedom of movement. After all other work is completed, all loose or thin shells of mortar likely to spall under movement shall be carefully removed from all expansion joints by means of a sharp chisel.

**S-813.03.3--Metal Railing.**

**S-813.03.3.1--Construction.** Fabrication and erection of ferrous metal shall be in accordance with the requirements of S-810. In the case of welded railings, all exposed joints shall be finished by grinding or filling to give a neat appearance.

Fabrication and erection of non-ferrous material shall be in general conformity with applicable requirements of S-810 and the specific requirements shown on the plans.

Metal railings shall be carefully adjusted prior to fixing in place to insure proper matching at abutting joints and correct alignment and camber throughout their length. Holes for field connections shall be drilled with the railing in place in the structure at the correct grade and alignment. Welding may be substituted for rivets in field connections with the approval of the Engineer.

Where galvanized ferrous metal railing is designated by the plans, the components shall be hot dip galvanized after fabrication in accordance with the requirements of the plans.

**S-813.03.3.2--Painting.** Painting shall conform to the requirements of S-710 and S-814.

**S-813.03.4--Wood Railings.** Wood railings will be constructed and paid for under the provisions of S-820.



**COMPENSATION**

**S-813.04--Method of Measurement.** Accepted bridge railing will be measured by the linear foot within the nominal measuring points of spans at bridge ends.

**S-813.05--Basis of Payment.** Bridge railing will be paid for at the contract unit price per linear foot of the type specified, which shall be full compensation for completing the work specified.

Payment will be made under:

**S-813-A:** Concrete Railing - per linear foot

**S-813-B:** Concrete-Steel Railing - per linear foot

**S-813-C:** Concrete-Aluminum Railing - per linear foot

**S-813-D:** \_\_\_\_\_ Railing - per linear foot  
(Type)

## SECTION S-814 - PAINTING METAL STRUCTURES

**S-814.01--Description.** This work consists of furnishing all materials and painting of metal structures. It shall include, unless otherwise provided in the contract, the preparation of metal surfaces, application, protection and drying of the paint coatings, supplying of all tackle, scaffolding and other essentials necessary to complete the work in reasonably close conformity with the specifications and as indicated on the plans.

The Coating System will consist of one shop coat of inorganic zinc, one field intermediate coat of acrylic latex and one field top coat of acrylic latex. The shop coat, intermediate coat and top coat shall each have a dry film thickness of not less than 3 mils nor more than 5 mils.

Touch-up paint for field repair of damaged areas in the inorganic zinc shop coat shall consist of epoxy mastic applied to a uniform dry film thickness of not less than 4 mils nor more than 6 mils.

### **S-814.02--Material.**

**S-814.02.1--Shop Coat (Prime Coat).** The paint shall be an inorganic zinc primer and meet the requirements of S-710.04.1.

**S-814.02.2--Acrylic Latex Intermediate Coat (Field Coat).** The paint shall meet the requirements of S-710.04.3.

**S-814.02.3--Acrylic Latex Top Coat (Field Coat).** The paint shall meet the requirements of S-710.04.3.

**S-814.02.4--Epoxy Mastic Touch-up Paint.** Field touch-up paint for repair of damaged inorganic zinc shop coat shall meet the requirements of S-710.04.2.

### **S-814.03--Construction Requirements:**

**S-814.03.1--Mixing of Paint.** All paint shall be mixed in accordance with the manufacturer's printed instructions.

**S-814.03.2--Weather Condition:** Solvent base paint shall not be applied when the surrounding air temperature is below 40°F. Waterborne paint shall not be applied when the surrounding air temperature is below 50°F. Paint shall not be applied when the surrounding air temperature is expected to drop to 32°F prior to drying of the paint. Paint shall not be applied when the metal is hot enough to cause blistering or produce a porous film. Paint shall not be applied when the steel surface is less than 5°F above the dew point nor shall it be applied in rain, snow, wind, fog, mist or when, in the opinion of the Engineer, conditions are otherwise unsatisfactory for the work.

**S-814.03.3--Application:**

**S-814.03.3.1--Shop Coat.** The coating shall be capable of being applied in accordance with specification requirements and shall be applied in accordance with the manufacturer's printed instructions.

After initial mixing, the paint shall be strained through a metal 30-60 mesh screen.

Stirring paddles on the mechanical mixing equipment shall reach to within one inch of the bottom of the paint container.

Airless spray equipment for application of inorganic zinc silicate paint shall provide pressure of not less than 2200 psi at the nozzle. The fluid hose between the pot and nozzle shall not be less than 3/8" inside diameter. Pressure may vary depending on tip size and pump.

Conventional spray equipment for application of inorganic zinc silicate paint shall provide pressure of not less than 10 psi at the pot and 30 psi at the nozzle.

**S-814.03.3.2--Acrylic Latex Intermediate and Top Coats (Field Coats).** All applications of the acrylic latex intermediate and top coats shall be in accordance with the manufacturers printed instructions. The primer coat and the intermediate coat shall have dried a minimum of eight hours under normal conditions prior to application for the intermediate and top coats, respectively. All surfaces shall be free of any soluble residue and surfaces on which the primer coat has been applied shall be free of excessive amounts of loose zinc before a subsequent coat is applied. Dust and dirt which may have accumulated on the surface shall be removed from the dried film with a soft brush or rag before application of a subsequent coat. When applied by brushing or spraying, the coating shall deposit a uniform dry film thickness without running or sagging.

**S-814.03.4--Removal of Paint.** If any painting is unsatisfactory, it shall be removed and the metal thoroughly cleaned and repainted.

**S-814.03.5--Thinning Paint.** Paint shall be thinned only in strict accordance with the manufacturer's recommendations.

**S-814.03.6--Painting Galvanized Surfaces.** Prior to application of the acrylic latex field coats, galvanized surfaces shall be primed with Epoxy Mastic Touch-Up Paint as specified in S-814.02.

**S-814.03.7--Cleaning of Surfaces.** Surfaces to be painted shall be thoroughly cleaned, removing rust, loose mill scale, dirt, oil or grease and other foreign substances.

All exposed and accessible surfaces of the metal shall be cleaned by sandblasting in accordance with the requirements of Steel Structures Painting Council SSPC-SP-10, Near White Blast Cleaning. The surface, regardless of starting condition, shall in the opinion of the Engineer or his designated representative be at least equal to the appearance of Pictorial Swedish Standard Sa 2 1/2 of SIS 05 59 00, SSPC-VIS 1.

All rust blooms shall be removed by reblasting before coating. The surface shall be constantly and diligently examined ahead of the coating operations for any traces of rust, oil, grease or blemishes not permitted by the blast cleaning specifications.

**S-814.03.8--Shop Painting:** Unless otherwise specified, the shop coat shall be applied immediately after the steel work has been accepted by the inspector.

Shop contact surfaces shall not be painted. Field contact surfaces except for machine finished pins and holes shall receive a shop coat with a minimum dry film thickness of 1 1/2 mils. All other surfaces which will be inaccessible after assembly or erection shall be given all required coats.

Surfaces which will be embedded or in contact with concrete shall not require painting unless otherwise noted on the plans. They may be painted in whole or partially due to overspray provided the paint thickness does not exceed the requirements specified for adjacent areas.

Structural steel which is to be field welded shall not be shop painted within two inches of the field welds.

All surfaces of iron and steel casting except for machine finished pins and holes shall be given two shop coats of paint.

Erection marks for field identification of members and weight marks shall be painted on areas previously painted with the shop coat. Material shall not be loaded for shipment until it is thoroughly dry and no sooner than 24 hours after the paint has been applied.

**S-814.03.9--Field Painting.** When the erection work is complete, including all bolting and straightening of bent metal, all rust, scale, dirt, grease and other foreign material shall be removed. As soon as the Engineer has approved all field welding and bolting, the surfaces from which the shop coat of paint has worn off or otherwise become defective shall be cleaned and reprimed with the specified touch-up paint prior to application of the intermediate coat.

Spans with concrete decks shall not be painted until after the deck is placed. All concrete spills and stains shall be washed from the structural steel prior to the mortar taking a set.

Surfaces to be bolted in contact and surfaces which will be in contact with concrete shall not have a field coat applied.

When the paint applied for retouching the shop coat has thoroughly dried and the field cleaning has been satisfactorily completed, the intermediate coat shall be applied. After the intermediate coat has thoroughly dried, the top coat shall be applied.

In no case shall a subsequent coat be applied until the previous coat has dried throughout the full thickness of the paint film. To secure a maximum coating on edges of plates or shapes, bolt heads and other parts subjected to special wear and attack, the edges shall be stripped with a longitudinal motion and bolt heads with a rotary motion of the brush followed immediately by the general painting of the whole surface, including recoating of the edges and bolt heads.

If, in the opinion of the Engineer, traffic produces an objectionable amount of dust, the Contractor shall, at his own expense, allay the dust for the necessary distance on each side of the bridge and take any other precautions necessary to prevent dust and dirt from coming in contact with freshly painted surfaces or surfaces prepared for painting.

The Contractor shall protect pedestrian, vehicular and other traffic upon or underneath the bridge and also all portions of the bridge superstructure and substructure against damage or disfigurement by spatters, splashes and smirches of paint or paint material. Any such disfigurement shall be removed at the direction of and to the satisfaction of the Engineer.

**S-814.03.10--Inspection.** The completed shop coat shall be inspected by the Contractor for thickness by means of elcometer or other approved magnetic detector thickness gage. Detection of insufficiently coated sections shall be marked and shall be coated over or touched up to establish the specified thickness.

All areas of the finished system deficient in thickness shall be coated over with the acrylic latex top coat paint to establish the specified thickness. Excessive thickness in the application of any coating evidenced by mudcracking will be cause for the affected area to be blast-cleaned and repainted.

Where rejection is due to poor workmanship or deficiency in the quality of the work or materials, the Contractor may be required to blast clean the entire defective sections of all previously applied materials prior to repainting.

Inspection shall be done in the presence of and to the satisfaction of the Engineer. The Engineer shall be provided access to the work to allow for proper inspection of the cleaning and painting at both the fabrication plant and the construction site.

**S-814.04--Method of Measurement.** Unless shown as a separate pay item in the proposal, painting of metal structures or members will not be measured for separate payment and the cost thereof shall be incidental to and included in the contract unit price(s) bid for other items.

**S-814.05--Basis of Payment.** When shown as a separate pay item in the proposal, painting will be paid for at the contract lump sum price which shall be full compensation for completing the work.

Payment will be made under:

**S-814-A:** Painting of Metal Structure - lump sum

**S-814-B:** Painting of \_\_\_\_\_ - lump sum  
(Description)

## **SECTION S-815 - RIP RAP AND SLOPE PAVING**

**S-815.01--Description.** This work consists of furnishing and placing a protective covering of erosion resistant material including plastic filter fabric, where shown on the plans for pier foundation protection, slope, or ditch protection. This work shall be in accordance with these specifications and in reasonably close conformity with the lines, grades and dimensions shown on the plans or established.

**S-815.02--Materials.** Materials shall conform to the following:

Geotextile fabric shall meet the requirements of S-714.13.

Aggregate for loose rip rap, stone rip rap for foundation protection, or that to be grouted shall consist of field stone, broken concrete, or rough, unhewn quarry stone as nearly rectangular in section as is practicable. The stone shall be dense, free of clay or shale seams, resistant to the action of air and water, and suitable in all other respects for the purpose intended. Quality requirements for rock to be furnished under these specifications will be checked or tested as determined by the MDOT Testing Engineer prior to use and subsequently if deemed appropriate.

Portland cement concrete aggregates, unless otherwise specified, shall conform to the applicable requirements of S-703.

Cloth sacks for concrete riprap in bags shall be of suitable cloth or jute which will hold the concrete mixture without leakage when handled. The sacks shall be of uniform size and dimensions, approximately 19½ x 36 inches measured inside the seams when the sack is laid flat. Sound reclaimed cloth sacks meeting the specified requirements may be used.

Paper sacks for concrete riprap in bags shall be a polyester fiber type of scrim reinforced paper. The top and bottom of the sacks shall have a pasted valve. When filled, they shall measure approximately 13 inches wide, 20 inches long, and five inches thick. Perforations shall be overall on one-inch centers with a diameter of 3/32 inch to 1/8 inch per hole. Each bag shall fill a space of approximately 0.71 cubic feet with 38 bags required per cubic yard. Pre-packaged riprap will be accepted on certification from the manufacturer.

Stones for rip rap, of the size specified, shall meet the requirements of S-705.04.

Material used for sediment control stone shall be crushed stone meeting the requirements of Subsection 703.03 for Size No. 57.

**S-815.03--Construction Requirements.**

**S-815.03.1--Construction Details.** Prior to the construction of rip rap or slope paving, the slopes or ground surface shall be shaped to lines and grades indicated on the plans or directed, and shall be thoroughly compacted by the use of mechanical or hand tamps. Unless otherwise stipulated or directed, slopes shall not be steeper than the natural angle of repose of the material upon which rip rap is to be constructed.

The outer edges and the top of the rip rap or slope paving where the construction terminates shall be formed so that the surface of the rip rap or slope paving will be embedded and even with the surface of the adjacent slope or ground, and the bottom of the rip rap or slope paving shall be placed at least two feet below the natural ground surface unless otherwise directed.

All rip rap or slope paving shall be started at the bottom of the slope and constructed upward.

No grout, bag rip rap, or slope paving shall be placed during freezing weather or while there is frost in the ground. In hot or dry weather grout and bag rip rap shall be kept moist and protected from the sun for at least three days after placing. Slope paving shall be cured in accordance with the provisions of S-815.03.7.4.

**S-815.03.2--Installation of Geotextile Fabric.** When required by the contract, geotextile shall be placed in the manner and at locations shown on the plans. The area to receive the geotextile shall be prepared to a relatively smooth condition free of obstructions, depressions and debris. The geotextile shall be placed loosely without wrinkles or creases with the long dimension perpendicular to the channel. The strips shall be placed to provide a minimum overlap of 18 inches. Securing pins with washers shall be inserted through both strips of overlapped geotextile at mid-point and not greater than two foot intervals. Additional pins shall be installed throughout the geotextile as necessary to prevent any slippage. The geotextile shall be placed so that the upstream strip overlaps the downstream strip and the higher slope strip overlaps the lower strip. Each securing pin shall be pushed through the geotextile until the washer bears against the geotextile and secures it firmly.

The geotextile shall be protected from contamination and damage during installation and placement of the specified cover material. Riprap shall not be dropped from a height greater than three feet. Contaminated geotextile shall be replaced, and damaged geotextile shall be repaired or replaced as directed at no cost to the Project.

The geotextile shall be covered with a layer of the specified material within 14 calendar days after placement. Geotextile not covered within this time period shall be removed and replaced at the Contractor's expense if damage or deterioration is evident, as determined by the Engineer.



**S-815.03.3--Loose Riprap.** The stones shall be placed upon a slope not steeper than the natural angle of repose of the slope material. The stones shall be laid with close joints. The courses shall be laid from the bottom of the bank upward with the larger stones being placed in the lower courses. Interstices shall be filled with smaller stones and spalls.

**S-815.03.4--Grouted Riprap.** Grout for grouted riprap shall consist of one part of Portland cement and three parts of approved sand thoroughly mixed with water to produce grout having a thick, creamy consistency.

The stones shall be of the size designated in the bid schedule of the contract and shall be placed in the same manner as specified for loose riprap.

Care shall be taken during placement to keep earth or sand from filling the spaces between the stones. After the stones are in place, the spaces between them shall be completely filled with grout from bottom to top and the surface swept with a stiff broom.

**S-815.03.5--Stone Riprap for Foundation Protection.** Stone riprap for pier and abutment protection shall range in size up to derrick stone and shall be graded from coarse to fine in such a manner as to produce a minimum of voids. It shall be deposited where directed. Stone deposited contrary to directions will be considered wasted and will not be paid for.

**S-815.03.6--Concrete Riprap in Bags.** Concrete riprap in bags shall consist of Class "D" concrete in approved bags and placed in conformity with contract requirements. Each bag shall be filled with approximately one cubic foot of concrete, securely tied, and immediately placed in the work and lightly trampled to cause them to conform with the slope or section required with adjacent bags in place. Unless otherwise specified in the contract, the bagged concrete shall be packed in such a manner as to give a reasonably uniform thickness of approximately 12 inches and shall be lapped and staggered as directed.

Pre-packaged riprap in paper bags shall be filled with kiln-dried mixture of portland cement and sand, or cement, sand and gravel with a ratio of three parts sand or sand and gravel to one part portland cement. The bags shall be placed to conform with the slope or required section and with adjacent bags in place. The bags shall be lapped and staggered as directed.

When shown on the plans, pipe headwalls shall be constructed of riprap in bags in accordance with these specifications and the plan details. In this construction, it is essential that the successive tiers are securely "keyed" by lapping, and the bags of concrete shall be lapped by at least one-half their length, when practicable.

**S-815.03.7--Slope Paving.** Concrete slope paving shall be constructed in a single layer in conformity with the design dimensions and details indicated on the plans.

**S-815.03.7.1--Forms.** Forms shall be wood or metal of sufficient strength to withstand the pressure of the concrete without bulging. They shall be adequately and securely staked true to line and grade.

**S-815.03.7.2--Mixing and Placing Concrete.** Unless otherwise stipulated, the concrete used in this construction shall be Class "C", mixed and placed in accordance with the provisions and requirements of S-804, except that volumetric batching may be used. Mixers of less than one bag rated capacity shall not be used.

**S-815.03.7.3--Finishing.** Concrete after spreading, shall be tamped and puddled until it is compact and sufficient mortar has been flushed to the surface so that it can be finished smooth with a wooden float. All edges shall be neatly edged using an approved short radius sidewalk edger.

**S-815.03.7.4--Curing.** After the concrete has set sufficiently, the surface shall be protected from premature drying by covering as soon as possible with a satisfactory material such as wetted burlap or wetted cotton mats and kept moist for a minimum of three days, or cured by other approved methods. Other approved methods include liquid membrane compound as set out in S-713.01.2, and polyethylene sheeting (white) conforming with the requirements of S-713.01.3. Both liquid membrane compound and polyethylene sheeting shall be maintained in place and intact for a minimum period of three days.

**S-815.03.7.5--Soil Sterilization.** Prior to placing slope pavement, the areas beneath the pavement shall receive soil sterilization treatment as set out in S-616.04.

**S-815.03.8--Cleaning Up.** Upon completion of the work, the surface of the riprap or slope paving shall be cleaned, surplus material and debris removed and disposed of as directed, and the site of the work left in a neat presentable condition.

### **COMPENSATION**

**S-815.04--Method of Measurement.** Loose rip rap complete in place and accepted will be measured in square yards or in tons, as specified. The pay area will be determined by using the outside dimensions of the area covered as directed. Tons or fraction thereof will be determined by railway weights or other satisfactory and approved method for determining weight. Stone placed contrary to directions will not be paid for.

Measurement or payment will not be made for grout, and the cost thereof shall be included in the compensation for grouted rip rap.

Concrete rip rap in bags will be measured in cubic yards as the quantity received or manufactured at the site of the work and acceptably placed in bags as required, but from the amount received or manufactured at the site, there will be deducted all excess determined by the Engineer to have been wasted or placed to unauthorized dimensions. The cubic yards of pre-package riprap in paper bags will be determined from the actual count of bags placed and accepted based on 38 bags per cubic yard.

Slope paving will be measured by the cubic yard computed using the dimensions shown on the plans, except that if authorized revisions are made in the finish grade or the configuration of the slope pavement, computations will be made considering the changed dimensions.

Geotextile complete in place and accepted will be measured by the square yard of surface area covered. Any extra width of material installed and additional material required for laps or sewing will not be measured. No separate payment shall be made for shipping, handling, storage, protection, fabrication, securing pins, or installation; the cost of which shall be included in the contract price for geotextile fabric.

**S-815.05--Basis of Payment.** Loose riprap will be paid for at the contract unit price per square yard or ton. Sediment control stone will be paid for at the contract unit price per cubic yard or ton. Grouted riprap will be paid for at the contract unit price per square yard. Concrete riprap in bags and concrete slope paving will be paid for at the contract unit price per cubic yard. Geotextile will be paid for at the contract unit price per square yard. Such payment shall be full compensation for completing the work.

Payment will be made under:

**S-815-A:** Loose Riprap, \_\_\_\_\_ lb. - per ton

**S-815-A-1:** Loose Riprap, \_\_\_\_\_ lb. - per square yard

**S-815-B:** Grouted Riprap - per square yard

**S-815-C:** Concrete Riprap in Bags - per cubic yard

**S-815-D:** Concrete Slope Paving - per cubic yard

**S-815-E:** Geotextile under \_\_\_\_\_, Type   \* , AOS   \* - per square yard  
(Description)

**S-815-F:** Sediment Control Stone - per ton

**S-815-F-1:** Sediment Control Stone - per cubic yard

\* When not designated, see S-714.13.

## **SECTION S-816 - MAINTENANCE PAINTING OF METAL STRUCTURES**

**S-816.01--Description.** This work consists of furnishing all materials, equipment and labor for the cleaning and painting of metal structures. It shall include, unless otherwise provided in the contract, the preparation of metal surfaces, the application, protection and drying of the paint coatings, supplying all tackle, scaffolding and other essentials necessary to complete the work in accordance with the specifications and as specified on the plans.

**S-816.02--Materials.** The coating system selected for maintenance painting must be lead free, VOC compliant and must be listed on the MDOT's Approved List of Materials under "Approved Coating Systems for Upgrading Existing Coatings by Maintenance Forces". The coating system shall consist of three coats as follows; an approved primer coat paint, intermediate coat paint and a top coat paint. The substitution of a primer, intermediate or top coat paint from one approved coating system to another is not permitted. The integrity of each approved coating system must be maintained.

When the project requires the painting of both new and existing metal structures, the different painting systems selected shall be from the same manufacturer and shall have the same top coat color.

### **S-816.03--Construction Requirements.**

**S-816.03.1--Weather Limitations.** Solvent base paint shall not be applied when the surrounding air temperature is below 40°F. Waterborne paint shall not be applied when the surrounding air temperature is below 50°F. Paint shall not be applied when the surrounding air temperature is expected to drop to 32°F prior to drying of the paint. Paint shall not be applied when the metal is hot enough to cause blistering or produce a porous film. Paint shall not be applied when steel surface is less than 5°F above the dew point nor shall it be applied in rain, snow, wind, fog, mist or when, in the opinion of the Engineer, conditions are otherwise unsatisfactory for the work.

**S-816.03.2--Pollution Control During Surface Preparation And Repainting.** Generated debris must be confined to the immediate area of the structure. Appropriate screens and barriers must be erected to protect pedestrian and vehicular traffic during waterblasting and painting operation. Overspray must be kept to a bare minimum.

**S-816.03.3--Surface Preparation.** Surface preparation will include waterblasting the entire surface followed by spot cleaning with hand tools to remove any remaining loose or flaking paint or rust, dirt, oil, grease and/or other deleterious matter from the steel surface. Tightly bonded paint is not to be removed and it is not necessary to remove tightly bonded rust.

In areas containing a heavy coating of oil, grease and/or deleterious material that cannot be cleaned by waterblasting, use BIOACT AE-O or an approved biodegradable solvent that is environmentally equivalent. Brush or mop the solvent on the surface with a rubbing action to loosen the film. Wipe off with a clean dry cloth and then rinse by waterblasting. Repeat as necessary until clean. The cleanliness of the surface shall be approved by the Engineer or a designated representative prior to beginning painting operations.

**S-816.03.3.1--Waterblasting.** The waterblasting unit must be capable of operating at pressures up to 4,000 psi at a water flow rate up to 10 gpm. The unit must be equipped with a water filter, pressure gage, nozzle with 1/8-inch orifice or one that will provide a jet stream of water, and sufficient length of hydraulic hose. The unit shall be equipped with a deadman control valve or other control valves that will provide automatic shut-off by release of the trigger. Water for blasting must be potable water to prevent damage to the pump and to insure a clean surface on the steel. During waterblasting operation, wood, insulation, electrical, instrumentation, etc., must be protected. After waterblasting, remove any remaining loose paint, loose rust and rust scale with wire brushes or other methods as necessary. Using the waterblast unit or compressed air, remove the loose debris generated from the hand tool cleaning operation. To prevent recontamination of the steel surface, the surface preparation operation should not be completed more than eight hours in advance of the painting operation. Should any recontamination occur prior to painting, repeat surface preparation procedures as necessary for removal. Before painting, the surfaces must be clean and dry. To enhance drying of the surfaces, compressed air may be used.

**S-816.03.3.2--Safety and Clean-Up.** During the cleaning of the existing steel, the Contractor may be dealing with hazardous material and the Contractor will be responsible for the health and safety of employees. The Contractor shall provide such items as protective clothing and respirators and make certain that they are used. The Contractor shall also be responsible for the maintenance and/or replacement of these items. The Contractor is advised that safety precautions for workers during each phase of work shall be in compliance with present OSHA standards.

The Contractor shall take necessary precautions to prevent an excessive amount of removed materials from falling beneath the structure. General debris must be confined to the immediate area of the structure. Appropriate measures shall be taken to protect the traveling public during surface preparation and painting operations.

The Contractor shall clean the area of excessive debris generated from cleaning and properly dispose of it at an approved landfill.

The Contractor shall take necessary steps to become familiar with any applicable Federal, State or local regulations and take the necessary actions for compliance when applicable to any portion of the required work.

**S-816.03.4--Packaging and Marking.** Multiple component paints shall be furnished in premeasured packages so as to form one unit of mixed paint when mixed with the vehicle in its container.

The containers for all paints shall be coated as necessary to prevent attack by the paint. Each container shall bear a label with the following information shown thereon: name and address of manufacturer, trade mark or trade name, kind of paint, date of manufacture and lot number, mixing instructions and equipment clean up instructions. The Volatile Organic Compounds (VOC) content shall be stated either on the label, product data sheet, or Material Safety Data Sheet.

**S-816.03.5--Acceptance Procedure.** Prior to use, the Contractor must furnish the Engineer a certificate from the manufacturer, covering each lot of paint in the shipment, attesting that the paint in the shipment conforms to the same formula as that originally approved by MDOT.

Final acceptance of the paint will be based on Manufacturer's Certification. The Engineer reserves the right to sample paint as he deems necessary. The use of any lot of paint prior to the Engineer's approval shall be prohibited.

**S-816.03.6--Mixing, Thinning and Application.** All paint shall be mixed and applied in accordance with the manufacturer's printed instructions. Paint shall be thinned only under conditions which follow strict accordance with the manufacturer's recommendations.

At the Engineer's request, the paint manufacturer's technical representative who is certified by the National Association of Corrosion Engineers (NACE) shall be present at the job site at the beginning of each separate coating operation as needed to provide technical expertise in the application of the field coats. This technical expertise shall be provided without additional cost to the Project. The Contractor shall be responsible for arranging for the presence of the manufacturer's technical representative.

Apply the paint to the Wet Film Thickness (WFT) that will obtain the Dry Film Thickness (DFT) required for the film being applied. The DFT required for each paint film of each approved coating system is set out in the MDOT's Approved List of Materials.

A subsequent coat shall not be applied until the previous coat has dried throughout the film thickness.

To secure a maximum coating on edges of plates or shapes, rivets, bolt heads and other parts subjected to special wear and attack, the edges shall be stripped with a longitudinal motion and the rivets and bolt heads with a rotary motion of a brush followed immediately by general painting of the whole surface, including recoating of the edges, rivets and bolt heads.

If, in the opinion of the Engineer, traffic produces an objectionable amount of dust, the Contractor shall, at no additional costs to the Project, allay the dust for the necessary distance on each side of the bridge and take any other precautions necessary to prevent dust and dirt from coming in contact with freshly painted surfaces or surfaces prepared for painting.

The Contractor shall protect pedestrian, vehicular and other traffic upon or underneath the bridge and also all portions of the bridge superstructure and substructure against damage or disfigurement by splatters, splashes and smirches of paint or paint material. Any such disfigurement shall be removed at the direction of, and to the satisfaction of the Engineer.

**S-816.03.7--Inspection.** The Contractor shall measure the paint thickness with an elcometer or other approved magnetic detector thickness gages. All areas of the finished system deficient in thickness shall be coated over with the finish paint to establish the specified thickness. Excessive thickness in the application of either coating evidenced by mudcracking will be cause for the effected area to be stripped of paint, cleaned and repainted.

Where rejection is due to poor workmanship or deficiency in the quality of the work or materials, the Contractor may be required to strip the entire defective sections of all previously applied materials and clean prior to repainting.

Inspection shall be done in the presence of and to the satisfaction of the Engineer.

**S-816.04--Method of Measurement.** Maintenance painting of structures and members will be measured lump sum or per each as provided in the contract.

**S-816.05--Basis of Payment.** Maintenance painting of structures and members will be paid for at the contract unit price per each or lump sum, which price will be full compensation for preparation of the surface, for furnishing and applying all materials and for all labor, tools, equipment and incidentals necessary to complete the work.

Payment will be made under:

**S-816-A:** Maintenance Painting of Metal Structure - lump sum

**S-816-B:** Maintenance Painting of Metal Structure, \_\_\_\_\_ - per each  
(Location / Description)

**S-816-C:** Maintenance Painting of \_\_\_\_\_ - lump sum  
(Description)

**Sections S-817 thru S-819 - Blank.**

## **SECTION S-820 - TIMBER STRUCTURES**

**S-820.01--Description.** This work consists of constructing timber structures in conformity with these specifications and in accordance with lines, grades, dimensions, and details shown on the plans.

### **S-820.02--Materials.**

**S-820.02.1--Lumber and Timber.** Lumber and timber shall conform to the requirements of S-718, and in the case of exposed permanent structures shall be treated as set out therein. Certain portions of untreated timber shall be coated as set out hereinafter and as may be shown on the plans.

**S-820.02.2--Rods, Plates, Eyebars, and Shapes.** Rods, plates, eyebars, and shapes shall be of structural steel conforming to the requirements of S-717.

**S-820.02.3--Castings.** Castings shall be cast steel or gray-iron, as specified, conforming to the requirements of S-716.02 or S-716.04.

**S-820.02.4--Hardware.** Machine bolts, drift bolts, and dowels may be either wrought iron or medium steel. Washers may be cast ogee or malleable castings, or they may be cut from medium steel or wrought iron plate, as specified.

Unless otherwise specified, machine bolts shall have square heads and nuts. Nails shall be cut or round wire of standard form. Spikes shall be cut or wire spikes, or boat spikes, as specified.

Nails, spikes, bolts, dowels, washers, and lag screws shall be galvanized unless otherwise specified.

### **S-820.03--Construction Requirements.**

**S-820.03.1--Storage of Material.** Lumber and timber stored on the site shall be kept in orderly piles or stacks. Untreated material shall be open-stacked on supports at least 12 inches above the ground surface to avoid absorption of ground moisture and to permit air circulation, and it shall be so stacked and stripped as to permit free circulation of air between the tiers and courses. It will be advisable in particular cases for the Engineer to require protection from the weather by a suitable covering. On glued laminated structural members that are not to be treated, an approved end sealer shall be applied after end trimming of each completed member.

### **S-820.03.2--Installing Timber Piling.**

**S-820.03.2.1--Driving Piling.** Timber piles shall be driven in accordance with the requirements of S-803.03.1, except as modified herein.



**S-820.03.2.2--Pile Hammer Formula.** Pile hammer formulas shall be per the requirements of S-803.03.1.9.2, except the use of gravity or drop hammers shall be allowed. In the absence of loading test, safe bearing values for piles driven with a gravity or drop hammer shall be determined by the following formula:

$$P = \frac{2WH}{S+1.0} \quad \text{for gravity or drop hammers}$$

**S-820.03.3--Timber Connectors.** Timber connectors shall be one of the following types, as specified on the plans: the split ring, the toothed ring, the shear plate, or the spike grid. The split ring and the shear plate shall be installed in pre-cut grooves of dimensions as given herein or as recommended by the manufacturer. The toothed ring and the spike grid shall be forced into the contact surface of the timbers joined by means of pressure equipment. All connectors of this type at a joint shall be embedded simultaneously and uniformly.

Fabrication of all structures using connectors shall be done prior to treatment. When prefabricated from templates or shop details, bolt holes shall not be more than 1/16 inch from required placement. Holes for round drift bolts shall be bored with a bit 1/16 inch less than the bolt to be used. The diameter for square drift bolts shall be equal to the least dimension of the bolt. Holes for machine bolts shall be bored with a bit the same diameter as the bolt. Bolt holes shall be bored perpendicular to the face of the timber.

Timber after fabrication shall be stored in a manner which will prevent changes in the dimensions of the members before assembly.

Dimensions of material and details not otherwise specified shall meet with the approval of the Engineer.

**S-820.03.4--Treated Timber.**

**S-820.03.4.1--Handling.** Treated timber shall be carefully handled without sudden dropping, breaking of outer fibers, bruising, or penetrating the surface with tools. It shall be handled with rope slings. Cant hooks, peaveys, spikes, or hooks shall not be used. Prior to driving, the timber piling shall not be handled in such a manner that it is subjected to excessive and undue abuse that might produce splitting, splintering or brooming of the wood.

**S-820.03.4.2--Placement.** All cutting, framing, and boring of treated timber shall be done before treatment insofar as practicable. When treated timbers are to be placed in waters infected by marine borers, untreated cuts, borings, or other joint framings below high water elevation shall be avoided.

**S-820.03.4.3--Cuts and Abrasions.** All cuts in treated piles or timbers, and all abrasions, after having been carefully trimmed, shall be covered with two applications of a mixture of 60 percent creosote oil and 40 percent roofing pitch, or brush coated with at least two applications of hot creosote oil and covered with hot roofing pitch.

**S-820.03.4.4--Bolt Holes.** All bolt holes bored after treatment shall be treated with creosote oil by means of an approved pressure bolt hole treater. Any unfilled holes, after being treated with creosote oil, shall be plugged with creosoted plugs.

**S-820.03.4.5--Temporary Attachment.** Whenever, with the approval of the Engineer, forms or temporary braces are attached to treated timber with nails or spikes, the holes shall be filled by driving galvanized nails or spikes flush with the surface or plugging holes as required for bolt holes.

**S-820.03.5--Untreated Timber.** In temporary structures of untreated timber the following surfaces shall be thoroughly coated with two coats of hot creosote oil before assembling: ends, tops, and all contact surfaces of sills, caps, floor beams, and stringers; and all ends, joints, and contact surfaces of bracing and truss members. The back faces of bulkheads and all other timber which is to be in contact with earth, metal or other timber shall be similarly treated.

Bolts passing through non-resinous wood shall be galvanized.

**S-820.03.6--Treatment of Pile Heads.** The heads of treated timber piles shall be protected as specified on the plans. If not specified, the fabric covering shall be used. The heads of timber piles, when the nature of the driving will unduly injure them, shall be protected by driving caps. When the area of the head of a timber pile is greater than that of the face of the pile hammer, a suitable cap shall be provided to distribute the blow of the hammer throughout the cross section of the pile. Fresh heading of a timber pile is recommended prior to driving. The head shall be cut square and shall be shaped or chamfered to prevent splitting at its periphery. Heads of all piling shall be square and a driving cap shall be provided to hold the axis of the pile in line with the axis of the hammer.

**S-820.03.6.1--Cutting Off of Timber Piles.** The tops of all piling shall be sawed to a true plane, as shown on the plans, and at the elevation fixed by the Engineer. Piles which support timber caps or grillage shall be sawed to conform to the plane of the bottom of the superimposed structure. In general, the length of pile above the cut-off elevation shall be sufficient to permit the complete removal of all material injured by driving, but piles driven to very nearly the cut-off elevation shall be carefully adzed or otherwise freed from all broomed, splintered or otherwise injured material. Pile heads, after cutting to receive the caps and prior to placing the caps, shall be treated in accordance with S-820.03.6.

**S-820.03.6.2--Defective Piles.** All piles damaged because of internal defects or by improper driving, driving out of the proper location, or driving below the specified elevation shall be corrected at no additional costs to the Project by one of the following methods approved by the Engineer for the pile in question:

- A. The pile shall be withdrawn and replaced by a new, and if necessary, a longer pile.
- B. A second pile shall be driven adjacent to the defective or low pile.
- C. A sufficient portion of the footing shall be extended to properly embed the pile. Timber piles shall not be spliced except as indicated on the plans for maintenance type projects. All piles pushed up by the driving of adjacent piles or by any other cause shall be driven down again.

**S-820.03.6.3--Metal Covering.** The sawed surface shall be covered with three applications of a mixture of 60 percent creosote oil and 40 percent roofing pitch or thoroughly brush-coated with three applications of hot creosote oil and covered with hot roofing pitch. Before placing the cap, a sheet of 12 gage, 0.028-inch zinc of good commercial quality or a sheet of 26 gage iron or steel of the quality of ASTM Designation: A 525 and galvanized each side shall be placed on each pile head. The sheet shall be of sufficient size to project at least four inches outside of the pile, and it shall be bent down, neatly trimmed and securely fastened to the face of the pile with large headed galvanized roofing nails.

**S-820.03.6.4--Fabric Covering.** The heads of all piles shall be covered with alternate layers of hot pitch and loosely woven fabric similar to membrane waterproofing, using four applications of pitch and three layers of fabric. The cover shall measure at least six inches more in dimensions than the diameter of the pile and shall be neatly folded down over the pile and secured by large headed galvanized nails or by binding or serving with not less than seven complete turns of galvanized wire securely held in place by large-headed galvanized nails and staples. The edges of the fabric projecting below the wire wrapping shall be trimmed to present a workmanlike appearance.

The heads of untreated piles shall be given one of the following treatments, as may be specified or directed by the Engineer:

- A. The sawed surface shall be thoroughly brush-coated with two applications of hot creosote oil.
- B. The sawed surface shall be heavily coated with paint, after which it shall be covered with cotton duck of a least eight-ounce weight, which shall be folded down over the sides of the pile and firmly secured thereto with large-headed roofing nails. The edges of the duck shall be trimmed to give a workmanlike appearance. The duck shall then be waterproofed by being thoroughly saturated and coated with one or more applications of approved paint.

**S-820.03.7--Holes for Bolts, Dowels, Rods and Lag Screws.** Holes for round drift bolts and dowels shall be bored with a bit 1/16 inch less in diameter than the bolt or dowel to be used. The diameter of holes for square drift bolts or dowels shall be equal to the least dimension of the bolt or dowel.

Holes for machine bolts shall be bored with a bit the same diameter as the bolt, except as otherwise provided in S-820.03.3.

Holes for rods shall be bored with a bit 1/16 inch greater in diameter than the rods.

Holes for lag screws shall be bored with a bit not larger than the body of the screw at the base of the thread.

**S-820.03.8--Bolts and Washers.** A washer, of the size and type specified, shall be used under all bolt heads and nuts which would otherwise come in contact with wood.

The nuts of all bolts shall be effectively locked after they have been finally tightened.

**S-820.03.9--Framing.** All lumber and timber shall be accurately cut and framed to a close fit in such manner that the joints will have even bearing over the entire contact surfaces. Mortises shall be true to size for their full depth, and tenons shall fit snugly. No shimming will be permitted in making joints, nor will open joints be accepted.

**S-820.03.10--Pile Bents.** Pile bents shall be constructed in accordance with applicable provisions of S-803.

**S-820.03.11--Framed Bents.**

**S-820.03.11.1--Mud Sills.** Untreated timber used for mud sills shall be of heart cedar, heart cypress, redwood, or other durable timber. Mud sills shall be firmly and evenly bedded to solid bearings and tamped in place.

**S-820.03.11.2--Concrete Pedestals.** Concrete pedestals for the support of framed bents shall be carefully finished so that the sills or posts will take even bearing on them. Dowels of at least 3/4-inch diameter and projecting at least six inches above the tops of the pedestals shall be set in them when they are cast for anchoring the sills or posts.

**S-820.03.11.3--Sills.** Sills shall have true and even-bearing on mud sills, piles, or pedestals. They shall be drift-bolted to mud sills or piles with bolts of not less than 3/4-inch diameter and extending into the mud sills or piles at least six inches. When possible, all earth shall be removed from contact with sills so that there will be free air circulation around them.

**S-820.03.11.4--Posts.** Posts shall be fastened to pedestals with dowels of not less than 3/4-inch diameter extending at least six inches into the posts.

Posts shall be fastened to sills by one of the following methods, as indicated on the plans:

- A. By dowels of not less than 3/4-inch diameter extending at least six inches into posts and sills.
- B. By drift bolts of not less than 3/4-inch diameter driven diagonally through the base of the post and extending at least nine inches into the sill.

**S-820.03.12--Caps.** Timber caps shall be placed, with ends aligned, in a manner to secure an even and uniform bearing over the tops of the supporting posts or piles. All caps shall be secured by drift bolts of not less than 3/4-inch diameter extending at least nine inches into the posts or piles. The drift bolts shall be approximately in the center of the post or pile.

**S-820.03.13--Bracing.** The ends of bracing shall be bolted through the pile, post or cap with a bolt of not less than 5/8-inch diameter. Intermediate intersections shall be bolted, or spiked with wire or boat spikes, as indicated on the plans. In all cases spikes shall be used in addition to bolts.

**S-820.03.14--Stringers.** Stringers shall be sized at bearings and shall be placed in position so that knots near edges will be in the top portions of the stringers.

Outside stringers may have butt joints with the ends cut on a taper, but interior stringers shall be lapped to take bearing over the full width of the floor beams or cap at each end. The lapped ends of untreated stringers shall be separated at least 1/2 inch for the circulation of air and shall be securely fastened by drift-bolting where specified. When stringers are two panels in length the joints shall be staggered.

Cross-bridging between stringers shall be neatly and accurately framed and securely toe nailed with at least two nails in each end. All cross-bridging members shall have full bearing at each end against the sides of stringers. Unless otherwise specified in the contract, cross-bridging shall be placed at the center of each span.

**S-820.03.15--Plank Floors.** Unless otherwise specified, planks used in this construction shall conform to the requirements set forth in S-820.02.1.

Single plank floor shall consist of a single thickness of plank supported by stringers or joists. The planks shall be laid heart side down, with 1/4-inch openings between them for seasoned material and with tight joints for unseasoned material. Each plank shall be securely spiked to each joist. The planks shall be carefully graded as to thickness and so laid that no two adjacent planks shall vary in thickness by more than 1/4 inch.

Two-ply timber floors shall consist of two layers of flooring supported on stringers or joists. The lower course shall be pressure treated with creosote oil. The top course may be laid either diagonally or parallel to the centerline of roadway as specified, and each floor piece shall be securely fastened to the lower course. Joints shall be staggered at least three feet. If the top flooring is placed parallel to the centerline of the roadway, special care shall be taken to securely fasten the ends of the flooring. At each end of the bridge these members shall be beveled.

**S-820.03.16--Laminated or Strip Floors.** The strips shall be of the grade required in S- 718. The strips shall be placed on edge at right angles to the centerline of the roadway. Each strip shall be spiked to the preceding strip at each end and at approximately 18-inch intervals with the spikes driven alternately near the top and bottom edges. The spikes shall be of sufficient length to pass through two strips and at least half-way through the third strip.

If timber supports are used, every other strip shall be toe-nailed to each timber support. The size of the spikes shall be as shown on the plans. When specified on the plans, the strips shall be securely attached to steel supports by the use of approved galvanized metal clips. Care shall be taken to have each strip vertical and tight against the preceding one and bearing evenly on all the supports.

**S-820.03.17--Wheel Guards and Railing.** Wheel guards and railing shall be accurately framed in accordance with the plans and erected true to line and grade. Unless otherwise specified, wheel guards, rails and rail posts shall be surfaced four sides, S4S. Wheel guards shall be laid in sections at least 12 feet long.

**S-820.03.18--Countersinking.** Countersinking shall be done wherever smooth faces are required. Horizontal recesses formed for countersinking shall be painted with hot creosote oil, and after the bolt or screw is in place shall be filled with hot pitch.

**S-820.03.19--Painting.** Rails and rail posts of untreated timber, or timber treated with preservative salts, shall be painted with three coats of paint.

Parts of the structure, other than rails and rail posts, which are to be painted, will be designated on the plans or in the special provisions.

Metal parts, except hardware, shall be given one coat of shop paint and after erection two coats of field paint as specified on the plans.

**S-820.04--Method of Measurement.** Timber remaining in the structure will be measured by the thousand feet board measure (MBM) which shall include the cost of all hardware, galvanizing, paint and painting. Computations of the amount of lumber and timber in the structure will be based on nominal sizes and the lengths indicated on the plans.

Piling will be measured in accordance with S-803.04.

Metal parts, other than hardware, will be measured in accordance with S-810.

**S-820.05--Basis of Payment.** Timber will be paid for at the contract unit price per thousand feet board measure, which price shall be full compensation for completing the work. Acceptable piling will be paid for at the respective contract prices per linear foot for the types and sizes specified, which price shall be full compensation for completing the work.

Payment will be made under:

- S-820-A:** Treated Timber - per MBM
- S-820-B:** Untreated Timber - per MBM
- S-820-C:** Untreated Timber Piling - per linear foot
- S-820-D:** Treated Timber Piling - per linear foot

**Section S-821 - Blank.**

**SECTION S-822 - NEOPRENE EXPANSION JOINTS**

**S-822.01--Description.** This work consists of furnishing and installing neoprene expansion joints in accordance with these specifications and details shown on the plans.

**S-822.02--Materials.** Expansion joints shall meet the requirements of S-707.07.

**S-822.03--Construction Methods.** Expansion joints shall be installed in accordance with the manufacturer's recommendations. The expansion material shall seal the deck surface, gutters and curbs to prevent moisture or other contaminants from leaking through the joints. Anchor bolts shall be cast-in-place or drilled and grouted at a spacing recommended by the manufacturer. The expansion material shall be installed in such a manner that the top surface of the material will be parallel to but not protrude above the roadway or bridge surface.

**S-822.04--Method of Measurement.** Neoprene expansion joints of the types specified will be measured in linear feet.

**S-822.05--Basis of Payment.** Neoprene expansion joints will be paid for at the contract unit price per linear foot, which price shall be full compensation for completing the work.

Payment will be made under:

**S-822-A:** \_\_\_\_ " Neoprene Expansion Joint, Type \_\_\_\_ - per linear foot

**Sections S-823 thru S-899 - Blank.**



## A

<b>Topic</b>	<b>Section or Subsection</b>	<b>Page</b>
Abbreviations of Organizations and Reference Materials, Definition of	S-101.01	1-1
Acceptance		
Final	S-105.16	1-40
Final Payment	S-109.11	1-89
Additive, Definition of	S-101.02	1-3
Adjustment of Castings, Grading, Utility Appurtenances	S-613	6-58
Adjustments and Disputes, Claims for	S-105.17	1-41
Admixture, Definition of	S-101.02	1-3
For Concrete	S-713.02	7-85
Advancement on Materials	S-109.06.2	1-84
Advance on Materials		
Payment for	S-109.07	1-85
Advertisement, Definition of	S-101.02	1-3
For Bids	S-102	1-14
Affidavit, Non-Collusion	S-102.06	1-17
Aggregates	S-703	7-20
Bedding Material for Pipe Culverts	S-603.04	6-10
Bedding Course, or Filter Material for Underdrains	S-704	7-39
Coarse, for Portland Cement Concrete	S-703.03	7-22
Dense-Graded Crushed Stone for Bases	S-703.04	7-25
Filter Material	S-704	7-39
Fine, for Mortar Sand	S-703.18	7-35
Fine, for Portland Cement Concrete	S-703.02	7-20
For Bituminous Surface Treatments	S-703.14	7-32
For Granular Materials	S-703.07	7-28
For Hot Mix Asphalt	S-703.06	7-26
For Stabilizer	S-703.20	7-35
General	S-703.01	7-20
Mineral Filler	S-703.16	7-34
Tables of Gradation	S-703.07.2	7-28

**Topic****Section or  
Subsection****Page**

Aggregate for Drainage	S-704	7-39
Agreement, Supplemental	S-101.02	1-11
	S-104.02	1-25
Agricultural Limestone	S-212	2-35
	S-715.02.2.1	7-109
Air-Entrained Concrete	S-804.02.10.1.2	8-58
Altered Quantities, Payment & Compensation for	S-109.03	1-81
Alternate, Design	S-101.02	1-3
Items	S-101.02	1-3
Amounts Due Contractors	S-109.01	1-78
Anchorage for Guard Rail	S-606.04	6-37
Anionic Emulsified Asphalt	S-702.07.2	7-13
Approach Embankment for Bridges	S-203.05	2-11
	S-801.09	8-4
Approval of Contract	S-103.07	1-24
Arch Pipe and Horizontal Elliptical Pipe, Concrete	S-603	6-9
Arch Pipe, Metal	S-709.02	7-62
Artifacts, Historical of Archeological	S-203.03	2-11
Asphalt: Application Temperatures Table IV	S-702.11	7-16
Cement(Petroleum)	S-702.05	7-11
Coated Fiber Glass Roving	S-230	2-52
Cutback	S-702.06	7-13
Emulsified	S-702.07	7-13
Pavement	S-400	4-1
Tack Coat	S-407	4-41
Asphaltic Cement or Petroleum Asphalt	S-702.12	7-17
Asphalt-Coated fiber Glass Roving	S-230	2-52
Assembling Steel	S-810.03.28.10	8-150
Audit, Right to	S-109.12	1-89
Authority & Duties of Inspectors	S-105.10	1-37
Authority of the Engineer	S-105.09	1-37
Availability of Plans & Proposals	S-102.02	1-14
Award: And Execution of Contract	S-103.02	1-21
Cancellation of	S-103.03	1-22
Definition of	S-101.02	1-3
of Contract	S-103.02	1-21

**B**

<b>Topic</b>	<b>Section or Subsection</b>	<b>Page</b>
Babbitt	S-716.09	7-117
Backfill and Embankment		
Formation Adjacent to Structures	S-203.09.3.3	2-17
Backfilling Conduits	S-603.09	6-15
Bags for Rip Rap	S-815.02	8-167
Bar:		
List	S-602.03	6-6
Mats	S-711.02.2	7-80
Reinforcing Steel	S-711.02	7-78
Table of Area & Weights	S-711.02.1	7-79
Barricades, Warning signs and Flaggers	S-107.10	1-53
Base Course, Definition of	S-101.02	1-3
Base & Subbase Courses:	S-300	3-1
Cement Treated	S-308	3-19
Granular	S-304	3-2
Line Treated	S-307	3-8
Lime-Fly Ash	S-311	3-37
Mechanically Stabilized Courses	S-310	3-31
Basement Soils, Definition of	S-101.02	1-4
Bearing Plates	S-811	8-155
Bearing Piles (Deep Foundations)	S-803	8-8
Bearing Values for Piles (Load Test)	S-803.03.1.9.2	8-14
Bearings:		
Miscellaneous Metals:		
Bronze	S-716.06	7-116
Copper	S-716.07	7-116
Self-Lubricating	S-716.08	7-117
Bedding	S-603.04	6-10
Bedding & Backfill for Pipe Culverts	S-603.04	6-10
	S-603.09	6-15
Bedding Course, or Filter Material	S-704.01	7-39
Bid Schedule, Interpretation of Quantities in	S-102.04	1-16
Bidder, Definition of	S-101.02	1-4
Bidders, Disqualification of	S-102.13	1-20
Bidding Requirements & Conditions	S-102	1-14
Binder Course, Definition of	S-101.02	1-4

## Bituminous Material:

Heating & Application		
Temperature	S-702.11	7-16
Joint Fillers	S-707.02	7-44
Measurement of	S-702.02	7-10
Materials	S-702	7-10
Working Temperatures for,	S-702.11	7-16
Table III	S-702.12	7-19
Mixing Plants	S-401.03.2	4-23
Pavements	S-403	4-30
Prime Coat	S-408	4-43
Recycled Pavement	S-401.02.3.1	4-4
Seal Coat	S-410	4-48
Surface Treatment	S-410	4-48
Tack Coat	S-407	4-41
Bituminous Materials	S-702	7-10
Blasting, Use of Explosives	S-107.11	1-55
Blind Drains	S-605.04	6-30
Blotter Materials	S-408.03 & S-410.03.1	4-43 4-48
Bolts, Nuts, Washers & Screws:		
For Steel Structures	S-717.02	7-121
Borrow, Definition of	S-101.02	1-4
Box Bridge, Definition of	S-101.02	1-4
Box Bridges, Materials	S-601 S-602	6-1 6-6
Box Culverts, Pipe Headwalls and Minor Structures	S-601.01	6-1
Brick	S-706.01	7-42
Brick Masonry	S-611	6-48
Bridge Site, Definition of	S-101.02	1-4
Bridges:		
And Structures	S-800	8-1
Box	S-601 S-602	6-1 6-6
Concrete	S-804	8-51
Construction Over		
Navigable Waters	S-107.09	1-56
Definition of	S-101.02	1-4
Excavation and Fill for	S-801	8-1
Reinforcement	S-805	8-109
Removal of	S-202.03	2-5
Steel	S-810	8-123
Bronze Castings & Bearings	S-716.06	7-116
Bulk Cement, Use of		
For Bases	S-308.09	3-24

**Topic**Bulk Cement  
Burlap**Section or  
Subsection**S-804.03.1.2  
S-713.01.1**Page**8-68  
7-85**INDEX****C**

<b>Topic</b>	<b>Section or Subsection</b>	<b>Page</b>
Calcium Chloride	S-714.02	7-89
Calendar Day, Definition of	S-101.02	1-4
Cancellation of Award	S-103.03	1-22
Care & Storage of Concrete Aggregates	S-804.02.4	8-52
Cast Iron Culvert Pipe	S-709.01	7-62
Castings:		
Bronze	S-716.06	7-116
	S-811.02.1	8-155
Gratings & Fittings	S-604.03.6	6-24
Gray Iron	S-716.04	7-116
Malleable	S-716.05	7-116
Steel	S-716.02	7-116
Catch Basins	S-604	6-23
Cationic Asphalt Emulsion	S-702.07.2	7-13
Cattle Passes, Concrete Pipe	S-603	6-9
Cement:		
Asphaltic, Definition of	S-700.02	7-2
Care & Handling of	S-308.02.3	3-19
	S-804.02.2	8-52
General	S-701	7-8
Hydraulic	S-701	7-8
Portland, Type I, II and III	S-701.01	7-8
Treated Courses	S-308	3-19
Certification of Compliance	S-106.04	1-46
Channel Excavation	S-203.02.5	2-9
Channel, Preservation of	S-801.02	8-1
Character of Employees, Methods & Equipment	S-108-05	1-71
Claims for Adjustments and Disputes	S-105.17	1-41
Classification of Excavation	S-203.02	2-8
Classification & Uses of Concrete	S-601.02	6-1
	S-804.02.6	8-53

STATE AID 2004 Topic	Section or Subsection	STATE AID 2004 Page
Cleaning up, Final	S-104.07	1-28
Clearing & Grubbing	S-201	2-2
Clearing & Grubbing of Bridge Sites	S-201.04	2-3
Cofferdams & Crib	S-801.05	8-2
Cold Milling	S-406	4-39
Cold Plastic Pavement Markings	S-620	6-77
Composition of Concrete for Bridges & Minor Structures	S-804.02.7	8-53
Commission, Definition of	S-101.02	1-4
Compensation for Altered Quantities	S-104.02 S-109.03	1-25 1-81
Composition for Asphalt Mixes	S-401.02.3	4-4
Concrete Curing Materials and Admixture	S-713	7-85
Concrete:		
Air-Entrained for Bridges & Minor Structures	S-804.02.10.1.2	8-58
Arch & Horizontal Elliptical Culvert Pipe	S-708.02	7-52
Base Course, Cement	S-308	3-19
Brick	S-706.01	7-42
Bridges and Structures	S-804	8-51
Classification & Use of	S-804.02.6	8-53
Composition of, for Bridges & Minor Structures	S-804.02.7	8-53
Culvert:		
Box	S-601	6-1
Pipe	S-603	6-9
Curb & Gutter	S-609	6-43
Curing:		
Bridges	S-804.03.17	8-81
Prestressed Members	S-804.03.22.4.2	8-103
Delivery of	S-804.03.5	8-68
Drain Tile	S-708.06	7-57
Exposed to Sea Water	S-804.03.11	8-75
Filler	S-812.03.3	8-157
Finishing Surfaces:		
Bridges	S-804.03.19	8-84
Structures, Minor	S-804.03.19	8-84
Gutter, Curb & Combination Curb & Gutter	S-609	6-43
Piles:		
Materials	S-719	7-136
Deep Foundations	S-803	8-8
	<b>Section or</b>	

Topic	Subsection	Page
Sheet Piling	S-802.02.1	8-6
Test Piles	S-803.03.1.11	8-20
	S-803.04.1	8-45
Pipe:	S-708	7-52
Cattle Pass	S-708.03	7-57
Culverts	S-603	6-9
Underdrains	S-605	6-28
Placement	S-803.03.2.7	8-38
Railing	S-813	8-159
Ready-Mix	S-804.02.11	8-60
Seal	S-804.03.9	8-73
Sewer Pipe	S-603.06.2	6-14
Sidewalks & Driveways	S-608	6-40
Steps & Minor Structures	S-601	6-1
Under Water	S-804.03.9	8-73
Concreting:		
Cold Weather	S-804.03.16.1	8-79
Hot Weather	S-804.03.16.2	8-81
Conduit:		
Drainage	S-603	6-9
Conformity:		
Definition of	S-101.02	1-5
Determination of	S-700.04	7-5
With Plans and Specifications	S-105.03	1-32
Consideration of Proposals	S-103.01	1-21
Construction Change Request,		
Definitions of	S-101.02	1-5
Construction Joints:		
Bituminous Pavements	S-401.03.12	4-29
Cement Treated Course		
(Construction Requirements-		
General)	S-308.04	3-21
Concrete Structures	S-804.03.10	8-74
Construction Over Navigable Waters	S-107.09	1-53
Construction & Maintenance of Detours		
and or Diversions	S-104.04	1-26
Construction Stakes, Lines & Grades	S-105.08	1-37
Contemplated Means Value (C.M.V.)	S-700.02	7-2
Contents of Proposal Forms	S-102.02	1-14
Contract:		
Approval of	S-103.07	1-24
Award of	S-103.02	1-21
Bond:		
Requirement of	S-103.05	1-22
Default & Termination of	S-108.08	1-74
Execution of	S-103.07	1-24

**Topic****Section or  
Subsection****Page**

Failure to Execute	S-103.08	1-24
Forms	S-102.02	1-14
Intent of	S-104.01	1-25
Payment Bond(Surety), Definition of(See Contract Bond)	S-101.02	1-5
Performance Bond, Definition of(See Contract Bond)	S-101.02	1-7
Subletting or Assignment of	S-108.01	1-68
Termination of Contract's Responsibility	S-108.10	1-77
Time, Determination & Extension of	S-108.06	1-72
Contract Unit Price	S-101.02	1-5
Contractor:		
Cooperation Between Contractors	S-105.07	1-36
Cooperation by	S-105.05	1-33
Definition of	S-101.02	1-5
Furnished Sources	S-106.02.2	1-45
Contractor's Responsibility for Utility Property & Service	S-107.18	1-59
Contractor's Responsibility For Work	S-107.17	1-58
Termination of Responsibility	S-108.10	1-77
Control of Materials	S-106	1-44
Control of Work	S-105	1-31
Controlling Work, Definition of	S-101.02	1-5
Cooperation Between Contractors	S-105.07	1-36
Cooperation by Contractor	S-105.05	1-33
Cooperation with Utilities	S-105.06	1-34
Coordination of Plans Specifications, Supplemental specifications, Special Provisions, and Notice(s) to Bidders	S-105.04	1-33
Copper Bearings & Sheet Copper	S-716.07	7-116
Corrugated Aluminum Pipe Underdrains	S-709.10	7-63
Corrugated Metal Culvert Pipe & Pipe Arches	S-709.02	7-62
Corrugated Metal Pipe for Underdrains	S-709.06	7-63
Corrugated Perforated Plastic Pipe	S-708.17	7-58
Cost of Repairs	S-107.17	1-58
County, Definition of	S-101.02	1-6
Creosote Oil & Creosote Coal Tar Solution	S-718.04	7-132
Cross Slope, Definition of	S-101.02	1-6



**Topic****Subsection****Page**

Culvert, Definition of	S-101.02	1-6
Excavation	S-603.03	6-10
Pipe	S-603	6-9
Pipe Relaid	S-603.07	6-14
Culverts and Storm Drains	S-603	6-9
Culverts, Box, Concrete	S-601	6-1
Curb & Combination Curb & Gutter	S-609	6-43
Curing Materials	S-713.01	7-85
Cutback Asphalts	S-702.06	7-13

**INDEX****D**

Damage Claims		
Responsibility for	S-107.14	1-57
Default & Termination		
of Contract	S-108.08	1-74
Defective Materials & Work	S-105.12	1-38
Definitions and Terms		
Glossary of Terms		
Materials & Tests	S-700.02	7-1
Delivery of Proposal	S-102.09	1-19
Department, Definition of	S-101.02	1-6
Design Grade, Definition of	S-101.02	1-6
Design Soil, Definition of	S-101.02	1-6
Determination & Extension		
of Contract Time	S-108.06	1-72
Determination of Conformity	S-700.04	7-5
Detour or Diversion, Construction		
& Maintenance of	S-104.04	1-26
Director, Definition of	S-101.02	1-6
Disputes and Claims	S-105.17	1-41
Disqualification of Bidders	S-102.13	1-20
Documentation,		
Definition of	S-101.02	1-6
Dowel Bars	S-711.02.4	7-80
Downspouts	S-603	6-9
Drain Tile	S-708.06	7-57
Drawings, Working	S-105.02	1-31
Driers for Paints	S-710.01	7-66
Drilled Shafts	S-803.03.2	8-20
Duties of the Inspector	S-105.10	1-37

**E**

<b>Topic</b>	<b>Section or Subsection</b>	<b>Page</b>
Earthwork	S-203	2-8
Earthwork, Maintenance of	S-203.11	2-19
Elastometric Bearings	S-714.10	7-93
Elements of Geometric Design, Definition of	S-101.02	1-6
Eliminated Items	S-109.05	1-83
Embankments:		
Areas, Preparation of	S-203.09.2	2-14
Compaction of	S-203.09.4	2-18
Construction	S-203.09	2-14
Formation of	S-203.09.3	2-15
Emulsified Asphalt	S-702.07	7-13
Engineer:		
Authority of	S-105.01	1-31
Definition of	S-101.02	1-6
Environmental Protection	S-107.22	1-61
Erosion Control Fabrics	S-231	2-54
Estimates, Interpretation of	S-102.04	1-16
Examination of Plans, Specifications, Special Provisions, Notice to Bidders, and Site of Work	S-102.05	1-16
Excavation:		
And embankment	S-203	2-8
And Fill for Bridges	S-203.05	2-11
Borrow	S-203.02.4	2-8
Channel	S-203.02.5	2-9
Classification of	S-203.02	2-8
Estimated On Site (E.O.S.E.)	S-203.02.10	2-9
Foundation Excavation for Bridges	S-801.01	8-1
Muck	S-203.02.3	2-8
Rock	S-203.02.2	2-8
Stripping	S-203.02.9	2-9
Structure excavation for Culverts, Boxes & Minor Structures	S-206	2-24
Surplus	S-203.02.8	2-9
Unclassified	S-203.02.1	2-8
Excelsior, Blanket	S-227	2-48
Execution & Approval of Contract	S-103.07	1-24

STATE AID 2004 Topic	Section or Subsection	STATE AID 2004 Page
Explosives, Use of	S-107.11	1-55
Extension of Contract time	S-108.06	1-72
Extra Depth Excavation for Bridges	S-801.10	8-4
	S-801.11	8-5
Extra & Force Account Work, Payment for	S-109.04	1-81
Extra Work	S-109.04	1-81
Extra Work, Definition of	S-101.02	1-6
Eyebars	S-810.03.15	8-142

## INDEX

### F

Fabricated Bar or Wire Mesh Mats	S-711.02	7-78
Failure to complete Work on Time	S-108.07	1-73
Failure to Execute Contract	S-103.08	1-24
Failure to Maintain Roadway or Structures	S-105.15	1-40
Falsework (for Bridges)	S-804.03.13	8-75
Falsework and Forms and Housing, Removal of	S-804.03.15	8-78
Federal Aid Participation	S-107.05	1-51
Fertilizer for Plant Material	S-212	2-35
Fertilizers	S-212.02	2-35
Fertilizing	S-212.05	2-36
Figure 1-Pavement Structure	S-100	1-93
Filler, Mineral	S-703.16	7-34
Filter Material	S-704	7-39
Final Acceptance	S-105.16	1-40
Final Cleaning Up	S-104.07	1-28
Final Payment	S-109.11	1-89
Fine Aggregate for Portland Cement Concrete	S-703.02	7-20
Finishing Concrete: Bridge Floors	S-804.03.19.7	8-91
Surfaces: Bridges	S-804.03.19.6.3	8-87
Sidewalks	S-804.03.19.9	8-99
Structures, Minor	S-804.03.19.6.2	8-87
Flaggers	S-618.03.2	6-69

Flared End Sections, Concrete	S-708.04	7-57
Flowable Fill	S-631	6-91
Fly Ash	S-714.05	7-91
Force Account Work	S-109.04	1-81
Forest Protection	S-107.13	1-56
Foundation Excavation for Bridges	S-801.01	8-1
Frames, Grates, Covers and Ladder Rungs	S-714.08	7-93
Freight Rates and Labor Rates	S-109.09	1-88
Fuel Adjustment	S-109.08	1-85
Furnishing Right-of-Way	S-107.19	1-60

## INDEX

### G

Galvanized Pipe	S-716.11	7-117
General Provisions	S-100	1-1
Geogrid Embankment Stabilization	S-240	2-66
Geometric Design, Definition of Elements of	S-101.02	1-6
Geotextile Fabrics	S-714.13	7-104
Glass Beads	S-710.03.5	7-68
Glossary of terms & Definitions:	S-101.01	1-1
	S-700.02	7-1
Grade and Line	S-105.08	1-37
Grade Separation Structures	S-107.08	1-52
Granular Courses	S-304	3-2
Granular Materials for Subbase and Base Courses	S-304.02	3-2
Gravel Aggregate for Concrete and Bituminous Mixed	S-703	7-20
Gray Iron Castings	S-716.04	7-116
Grillage, Placing of	S-804.03.18.8	8-84
Ground Preparation	S-212.04	2-35
Grout	S-714.11	7-98
Grouting	S-804.03.22.4.4	8-104
Guard Post, Materials	S-718	7-130
Guard Post, Construction	S-606.03	6-36
Guard Rail	S-606	6-35
	S-712	7-84
Guardrail Posts, Materials	S-606.02.3	6-35

**H**

Hammers for Piles	S-803.03.1.7.3	8-11
Hazardous or Toxic Waste	S-107.25	1-66
Header Curb	S-609	6-43
Headwalls:		
Bag Rip Rap	S-815.03.6	8-169
Concrete	S-601	6-1
Precast Flared End Sections	S-708.04	7-57
High Tensile Strength Bolts	S-717.02	7-121
High Voltage Overhead Lines	S-105.06.1	1-35
Highway, Definition of	S-101.02	1-7
Holes for Prestressing bars	S-804.03.22.3.3	8-103
Holidays	S-101.02	1-7
Hot Mix Asphalt Pavement	S-403	4-30
Hot Spray Paint Traffic Markings	S-619	6-72
Hourly Rental Schedule	S-109.04	1-82
Hydrated Lime	S-714.03.2	7-89
Hydraulic Cement	S-701	7-8

**INDEX****I**

Imperfect Trench Method	S-603.10	6-15
Increment, Definition of	S-700.02	7-2
Inlets	S-604	6-23
Inspector, Authority of	S-105.10	1-37
Definition of	S-101.02	1-7
Duties of	S-105.10	1-37
Insurance, Public Liability	S-103.06	1-22
Items, Eliminated	S-109.05	1-83
Intent of Contract	S-104.01	1-25
Intent of Plans & Specifications	S-102.05	1-16
Interpretation of Quantities in Bid Schedule	S-102.04	1-16
Invitation for Bids, Definition of	S-101.02	1-8

**J**

<b>Topic</b>	<b>Section or Subsection</b>	<b>Page</b>
Joining Conduit	S-603.06	6-12
Joint Bids	S-102.01	1-14
Joint Filler and Seals	S-707	7-44
Joint Materials	S-707	7-44
Joints:		
Cleaning and Sealing	S-413	4-71
For Bituminous Pavement	S-401.03.12	4-29
	S-411.03.3.3.2	4-69
For Sanitary Sewers	S-603.06.2	6-14
for Structures	S-804.03.18	8-82

**INDEX****L**

Laboratory:		
Definition of	S-101.02	1-8
Labor Rates	S-109.04 &	1-81
	S-110.02	1-91
Lacing Bars	S-810.03.10	8-140
Laws to be Observed	S-107.01	1-50
Lead Plates, Pipe, etc.	S-716.10	7-117
Legal Relations & Responsibility		
to Public	S-107	1-50
Legal Rights, No Waiver of	S-107.21	1-60
Liability, Personal, of Public		
Officials	S-107.20	1-60
Licenses	S-107.02	1-50
Lime:		
Application	S-307.06	3-11
Hydrated	S-307.01	3-8
Treated Courses	S-307	3-8
Limestone, Agricultural	S-212.02	2-35
	S-715.02.2.1	7-109
Limitations of Operations	S-108.04	1-69
Line and Grade	S-105.08	1-37
Linear Grading	S-208	2-27

**Topic****Section or  
Subsection****Page**

Liquid Limit (L.L.)		
Definition of	S-700.02	7-2
Liquid Membrane Curing		
Compound	S-713.01.2	7-85
Load & Speed Restrictions	S-105.13	1-39
Loading Test for Piles	S-803.03.1.9.4.2.1	8-15
Local Materials Sources	S-106.02	1-44
Loess, Definition of	S-700.02	7-2
Loose Vehicular		
Measurement	S-109.01	1-78
Lot, Definition of	S-700.02	7-2
Lumber	S-718	7-130

**INDEX****M**

Maintain, Failure to	S-105.15	1-40
Maintenance:		
of Earthwork	S-203.11	2-19
of Traffic	S-104.04	1-27
During Construction	S-618	6-66
During Construction	S-105.14	1-39
Malleable Castings	S-716.05	7-116
Manholes, Inlets and		
Catch Basins	S-604	6-23
Manufacture of:		
Prestressed Concrete Bridge		
Members	S-804.03.22	8-100
Marginal Bars	S-711.02.4	7-80
Masonry Units	S-706	7-42
Masonry:		
Blocks, Concrete	S-706.03	7-42
Brick	S-706.01	7-42
Brick, Concrete	S-706.02	7-42
Concrete	S-604.03.2	6-24
Match Marking	S-202.03	2-6
Materials and Tests	S-700	7-1
Materials for Signing	S-721	7-153
Materials:		
Contractor Furnished		
Sources	S-106.02.2	1-45
Control of	S-106	1-44
Defective	S-105.12	1-38

**Topic****Subsection****Page**

Definition of Foreign	S-101.02	1-8
Found on the Work, Rights	S-106.07	1-48
In and use of	S-104.06	1-28
General Requirements	S-700.01	7-1
Glossary of Terms & Definitions	S-700.02	7-1
Guaranty	S-102.14	1-20
Handling of	S-106.09	1-49
Local	S-106.02	1-44
Storage of	S-106.08	1-49
Pits	S-107.23	1-65
Measurement:		
And Payment	S-109	1-78
Final (FM)	S-203.12.1	2-19
Final Measure Embankment (F.M.E.)	S-203.12.7	2-20
Loose Vehicular (L.V.M.)	S-203.12.3	2-20
Of Quantities & Determination		
Of Amounts Due Contractors	S-109.01	1-78
Plan Measurement (PM)	S-203.12.2	2-19
Mechanically Stabilized		
Courses	S-310	3-31
Median and Island Pavement	S-616	6-60
Metal Pipe	S-709	7-62
Methods & Equipment	S-108.05	1-71
Mineral Filler	S-703.16	7-34
Minor Structures, Concrete	S-601.01	6-1
Miscellaneous Materials	S-714	7-87
Miscellaneous Metals	S-716	7-116
Mixed Paints	S-710.02	7-67
	S-710.05.1.3	7-74
Mixers, Truck	S-804.02.11	8-60
Mixing Concrete	S-806.03.3.1	8-114
Mobilization	S-200	2-1
Monuments, Historical	S-203.03	2-11
Mortar and Grout	S-714.11	7-98
Mortar for Masonry	S-714.11.5	7-99
Mortar Sand	S-703.18	7-35
Mulch for Plant Materials	S-215.02	2-42
Mulching	S-215	2-42



## N

<b>Topic</b>	<b>Section or Subsection</b>	<b>Page</b>
Neoprene Pads	S-714.10.2	7-93
Noise Abatement	S-107.24	1-66
Non-Collusion Affidavit	S-102.06	1-17
Non-Metal Structures and Cattlepasses	S-708	7-52
Notice to Bidders, Definition of	S-101.02	1-8
Notice to Proceed	S-108.02	1-69
No Waiver of Legal Rights	S-107.21	1-60
Numerically-Controlled Drilled Field Connections	S-810.02.11.2	8-127

## INDEX

## O

Oil For Preservatives	S-718.04.1	7-132
Omitted Items, Payment for	S-109.05	1-83
Opening Bridges	S-804.03.20	8-99
Opening Sections of Project to Traffic	S-107.16	1-57
Operations, Limitations of	S-108.04	1-69
Optimum Moisture, Definition of	S-700.02	7-3
Order Lists:		
For Deep Foundations	S-803.01.2	8-8
For Reinforcement	S-805.02.1	8-109
Overburden, Definition of	S-700.02	7-3
Oxygen Cutting	S-810.03.6	8-139

## INDEX

## P

Paint	S-710	7-66
Painting Metal Structures	S-814	8-162
Painting Steel Piles & Steel Piles Shells	S-803.02	8-8

STATE AID 2004 Topic	Section or Subsection	STATE AID 2004 Page
Partial Payments	S-109.06	1-83
Patented Devices, Material & Processes	S-107.03	1-51
Paved Ditch	S-229	2-51
Pavement:		
Bituminous	S-400	4-1
Definition of	S-101.02	1-9
Hot Mix Asphalt	S-403	4-30
Plant Mix, Description	S-401	4-1
Samples	S-401.02.5.3	4-9
Structures, Definition	S-101.02	1-11
Structure, Figure 1	S-100	1-93
Surface Treatment, Bituminous	S-410	4-48
Pavement Marking Materials	S-619	6-72
	S-620	6-77
	S-621	6-79
	S-720	7-138
Payment:		
Final	S-109.11	1-89
For Extra and Force Account Work	S-109.04	1-81
For Material on Hand	S-109.07	1-85
For Omitted Items	S-109.05	1-83
Of Withheld Funds	S-109.10	1-88
Partial	S-109.06	1-83
Scope of	S-109.02	1-80
Pea Gravel, Definition	S-700.02	7-3
Permits, Licenses and Taxes	S-107.02	1-50
Personal Liability of Public Officials	S-107.20	1-60
Petroleum Asphalt Cement	S-702.05	7-11
Pigment	S-710.03.3	7-67
	S-710.05.1.1	7-74
Pigmentation	S-720.04.2.6	7-141
Piles	S-719	7-136
Piles:		
Concrete Sheet Piles	S-802.02.1	8-6
Cut Offs	S-803.03.1.4	8-9
Deep Foundations	S-803	8-8
Defective Piles	S-803.03.1.8	8-13
Description	S-803.01.1	8-8
Determination of Bearing Value	S-803.03.1.9	8-13
Extensions or Buildups	S-803.03.1.3	8-9
Formulas	S-803.03.1.9.2	8-14

<b>Topic</b>	<b>Section or Subsection</b>	<b>Page</b>
Loading Tests	S-803.03.1.9.4.2.1	8-15
Manufacture:		
Of Prestressed Concrete	S-804.03.22	8-100
Materials	S-719	7-136
Method of Driving	S-803.03.1.7	8-10
Order Lists for Deep Foundations	S-803.01.2	8-8
Pre-formed Pile Holes	S-803.03.1.7.4.5	8-12
Preparation for Driving	S-803.03.1.6	8-10
Preparation of Foundation		
For Footings	S-801.04	8-1
Pretensioning and Post-tensioning	S-804.03.22	8-100
Sheet Piling,		
Description of	S-802.01	8-6
Steel Sheet Piles	S-719.05	7-137
	S-802.02.2	8-6
Storage & Handling of		
Prestressed Concrete	S-804.03.22.6	8-105
Test Piles	S-803.03.1.11	8-20
Pin Clearance	S-810.03.19	8-143
Pin Connections	S-810.03.28.12	8-150
Pins and Rollers	S-810.03.17	8-143
Pipes:		
Bedding	S-603.04	6-10
Bituminous Coated Corrugated		
Aluminum Alloy Culvert Pipe		
and Arches	S-709.11	7-63
Bituminous Coated Corrugated		
Metal Pipe and Pipe Arches	S-709.03	7-62
Bituminous Coated Corrugated		
Metal Pipe for Underdrains	S-709.07	7-63
Bituminous Coated Paved Invert		
Corrugated Aluminum Alloy		
Culvert Pipe and Arches	S-709.12	7-63
Bituminous Coated Paved Invert		
Corrugated Metal Pipe		
and Arches	S-709.05	7-63
Cast Iron Culvert Pipe	S-709.01	7-62
Concrete	S-708.02	7-52
Concrete Arch	S-708.14	7-57
Elliptical Concrete Culvert	S-708.15	7-57
Concrete Drain Tile	S-708.06	7-57
Concrete Pipe Cattlepass	S-708.03	7-57
Corrugated Aluminum Alloy		
Culvert Pipe & Arches	S-709.09	7-63

<b>Topic</b>	<b>Section or Subsection</b>	<b>Page</b>
Corrugated Aluminum Alloy Pipe for Underdrains	S-709.10	7-63
Corrugated Metal Culvert Pipe & Pipe Arches	S-709.02	7-62
Corrugated Metal Pipe for Underdrains	S-709.06	7-63
Drain Tile	S-708.06	7-57
Galvanized	S-709.02	7-62
Nonreinforced Concrete Pipe	S-708.02.4	7-54
Perforated Plastic Pipe	S-708.20	7-59
Plastic Sewer Pipe and Fittings	S-708.18	7-58
Polymer Coated Corrugated Metal	S-709.08	7-63
Porous Concrete Pipe for Underdrains	S-708.07	7-57
Relaid	S-603.07	6-14
Reinforced Concrete Pipe	S-708.02.5	7-54
Reinforced Concrete Flared end Sections	S-708.04	7-57
Removed	S-202.04	2-6
Special Sections (Non-Metal)	S-708.23	7-61
Special Sections (Metal)	S-709.18	7-64
Underdrains	S-605	6-28
<b>Plans:</b>		
Alteration of	S-104.02	1-25
And Working Drawings	S-105.02	1-31
Conformity with	S-105.03	1-32
Coordination of	S-105.04	1-33
Definition of	S-101.02	1-9
Examination of	S-102.05	1-16
Intent of	S-102.05	1-16
Specifications, Supple- mental Specifications, Special Provisions, Notice to Bidders, Coordination of	S-105.04	1-33
Plant Inspection	S-106.05	1-48
Plant Mixtures, Bituminous	S-400	4-1
Plastic Filter Fabric	S-714.13	7-104
Plastic Limit (P.L.), Definition of	S-700.02	7-3
Plasticity Index, Definition of	S-700.02	7-3

<b>Topic</b>	<b>Section or Subsection</b>	<b>Page</b>
Plate Cut Edges	S-810.03.4	8-139
Pneumatic Placing of Concrete	S-804.03.7	8-72
Polyethylene Sheeting (White)	S-713.01.3	7-85
Porous Concrete Pipe for Underdrains	S-708.07	7-57
Portland Cement	S-701.01	7-9
Portland Cement: Treated Courses	S-308	3-19
Posttensioning	S-804.03.22.2.3	8-102
Precast Concrete Box Culverts	S-708.22	7-60
Precast Caps, Spans, Wings and Barrier Rails	S-806.03.3	8-114
Precast, Prestressed Concrete Bridge Members	S-804.03.22	8-100
Preformed Joint Filler	S-707.02.2	7-47
Preformed Pile Holes	S-803.03.1.7.4.5	8-12
Premixing Granular Materials	S-304.07	3-4
Preparation of Foundations and Footings	S-801.04	8-1
Preparation of Grade	S-205	2-22
Preparation of Proposal	S-102.06	1-17
Prequalification of Bidders	S-102.01	1-14
Preservation of Channel	S-801-02	8-1
Preservative Oils for Timber	S-718.04	7-132
Pressure Grouting	S-612	6-51
Prestressed Concrete Bridge Members	S-804.03.22	8-100
Pretensioning	S-804.03.22.2.1	8-100
	S-804-03.22.2.3	8-102
Prime Coat, Bituminous	S-408	4-43
Profile Grade, Definition of	S-101.02	1-9
Property Damage Liability Insurance	S-103.06	1-22
Proposal Forms: Charge for	S-102.02	1-15
Contents of	S-102.02	1-14
Definition of	S-101.02	1-9
Proposal Guaranty Definition of	S-101.02	1-9
Return of	S-103.04	1-22
Proposals: Combination or Conditional	S-102.11	1-20

**Topic****Section or  
Subsection****Page**

Consideration of	S-103.01	1-21
Contents	S-102.02	1-14
Definition of	S-101.02	1-9
Delivery of	S-102.09	1-19
Guaranty	S-102.08	1-19
Interpretation of		
Quantities	S-102.04	1-16
Irregular	S-102.07	1-18
Issuance of	S-102.03	1-15
Non-Collusion Affidavit	S-102.06	1-17
Preparation of	S-102.06	1-17
Public Opening of	S-102.12	1-20
Withdrawal or Revision of	S-102.10	1-19
Prosecution and Progress	S-108	1-68
Protection and Restoration of		
Property and Landscape	S-107.12	1-55
Public Convenience and		
Safety	S-107.07	1-52
Public Officials, Personal		
Liability of	S-107.20	1-60
Pumping Concrete	S-803.03.2.7.3	8-39
	S-804.03.8	8-73
Pumping Foundations	S-801.06	8-3

**INDEX****Q**

Quantities:		
Alteration of	S-104.02	1-25
Interpretation in Bid		
Schedule	S-102.04	1-16
Measurement of and		
Determination of		
Amounts Due Contractor	S-109.01	1-78

**INDEX****R**

Railing	S-813	8-159
Railway-Highway Provisions	S-107.08	1-52
Railway Requirements	S-107.08	1-52
Raised Pavement markers	S-627	6-83

STATE AID 2004 Topic	Section or Subsection	STATE AID 2004 Page
Rapid Curing Cutback Asphalt	S-702.06.1	7-13
Rates, Labor, Materials and Equipment for Extra Work	S-109.04	1-81
Rates, Freight and Labor, No Additional Allowance for	S-109.09	1-88
Reclaimed Asphalt Pavement (RAP)	S-401.02.3.1	4-4
Reflective Sheeting	S-721.06	7-157
Reflectorized Signs	S-630	6-86
Reinforced Concrete Pipe	S-708.02.5	7-54
Reinforcement	S-711.01	7-78
Reinforcing Steel	S-711.02	7-78
Reinforcement and Wire Rope	S-711	7-78
Relaid Pipe	S-603.07	6-14
Removal of Falsework, Forms & Housing	S-601.09.3 S-804.03.15	6-2 8-78
Removal of Structures and Obstructions	S-104.05	1-27
Removal of Unacceptable & Unauthorized Work	S-105.12	1-38
Rental Rates	S-109.04	1-82
Responsibility for Damage Claims	S-107.14	1-57
Responsibility for Work, Contractor's	S-107.17	1-58
Restoration of Surfaces Opened by Permit	S-107.04	1-51
Right-of-Way, Definition of	S-101.02	1-10
Right-of-Way, Furnishing	S-107.19	1-60
Right-of-Way Markers	S-617	6-64
Rights In and Use of Material Found on the Work	S-104.06	1-28
Riprap: And Slope Paving	S-815	8-167
Concrete in Bags	S-815.03.6	8-169
Grouted	S-815.03.4	8-169
Size	S-815.02	8-167
Stone	S-815.03.5	8-169
Roadbed, Definition of	S-101.02	1-10
Roadbed Reclamation	S-632	6-94
Roadside, Definition of	S-101.02	1-10

**Topic****Section or  
Subsection****Page**

Roadside Development		
General	S-210	2-30
Definition of	S-101.02	1-10
Materials	S-715	7-107
Roadway, Definition of	S-101.02	1-10
Roadway Structure,		
Definition of	S-101.02	1-10
Rock Excavation	S-203.02.2	2-8
Rolled Zinc	S-716.12	7-117
Rubber-Type Gaskets for		
Joining Conduits	S-707.04	7-49

**INDEX****S**

Salvage	S-202.03	2-6
Sample, Definition of	S-700.02	7-3
Samples, Tests & Cited		
Specifications	S-106.03	1-46
Sampling and Testing	S-700.03	7-5
Sand, Definition of	S-700.02	7-3
Sand-Clay, Definition of	S-700.02	7-3
Sanitary Provisions	S-107.06	1-52
Screenings, Definition of	S-700.02	7-3
Scope of Payment	S-109.02	1-80
Scope of Work	S-104	1-25
Seal Coat	S-410	4-48
Seed	S-715.03	7-109
Seeding	S-214	2-38
Settlement by Blasting	S-203.10	2-19
Shale, Definition of	S-700.02	7-3
Shell	S-703.20.2.2	7-36
Sheet Piling	S-802	8-6
Shoulder, Definition of	S-101.02	1-10
Shoulders	S-320	3-42
Shrinkage Limit (S.L.)		
Definition of	S-700.02	7-3
Sidewalk, Definition of	S-101.02	1-10
Sidewalks	S-608	6-40
Sieves, Definition of	S-700.02	7-4
Signs and Barricades	S-107.10	1-53
	S-630	6-86
Siltation and Pollution	S-107.12	1-55
Silt, Definition of	S-700.02	7-4



STATE AID 2004 Topic	Section or Subsection	STATE AID 2004 Page
Silt Fence	S-233	2-58
Slag, Definition of	S-700.02	7-4
Slag for Bases	S-703.20.2.1	7-36
Slurry Seal	S-411	4-59
Solid Sodding	S-226	2-45
Source of Supply & Quality Requirements	S-106.01	1-44
Special Provisions, Definition of	S-101.02	1-10
Specific Gravity, Definition of	S-700.02	7-4
Specifications, Conformity With	S-105.03	1-32
Definition of	S-101.02	1-10
Examination of	S-102.05	1-16
Splicing of Reinforcement	S-602.06.1	6-7
Stabilization Fabric	S-232	2-56
Standard Density, Definition of	S-700.02	7-4
Standard Operating Procedure, Definition of	S-101.02	1-11
Standard Terms	S-101.03	1-14
State, Definition of	S-101.02	1-11
Steel:		
Castings	S-716.02	7-116
Forgings	S-716.03	7-116
Grid Flooring	S-812	8-156
Identification During Fabrication	S-810.03.25.2	8-145
Piles	S-719.04	7-137
	S-803.02	8-8
Post for Small Signs	S-721.02.3	7-154
Sheet Piling	S-719.05	7-137
	S-802.02.2	8-6
Structural	S-717	7-119
Fabrication by Numerically-Controlled Drilled Field Connections	S-810.02.11.2	8-127
Tightening High Strength Bolts	S-810.02.20	8-131
Members:		
Straightening Bent Material	S-810.03.28.8	8-149
Cambering	S-810.03.28.9	8-149
Structures	S-810	8-123
Wire Fabric	S-711.02.3	7-80
Stone Blanket Protection and		

**Topic****Section or  
Subsection****Page**

Filter Blanket Materials	S-705	7-40
Structural Steel	S-717	7-119
Structural:		
Concrete for Minor Structures	S-601.01	6-1
Steel	S-717	7-119
Timber and Lumber	S-718	7-130
Structural Concrete	S-601	6-1
Structure Excavation for Culverts & Minor Structures	S-206	2-24
Structures, Definition of	S-101.02	1-11
Structures and Obstructions Removal and Disposal of	S-202	2-5
Subbase Course, Definition of	S-101.02	1-11
Subbases and Bases	S-300	3-1
Subcontractor, Definition of	S-101.02	1-11
Subgrade, Definition of	S-101.02	1-11
Subgrade, Preparation	S-205	2-22
Subletting of Contract	S-108.01	1-68
Substructure, Definition of	S-101.02	1-11
Superintendent, Definition of	S-101.02	1-11
Superstructure, Definition	S-101.02	1-11
Supplemental Agreement Definition of	S-101.02	1-11
Supplemental Specifications, Definition of	S-101.02	1-11
Surety, Definition of	S-101.02	1-12
Surface Treatment, Bituminous	S-410	4-48

**INDEX****T**

## Tables:

Coarse Aggregate for Cement Concrete	S-703.03.2.4	7-24
Composite Graduations for Mechanically Stabilized Courses	S-703.08	7-31
Deleterious Substances in Course Aggregate for Cement Concrete	S-703.03.2.1	7-23

Cover Aggregates for Bituminous Surface Treatments	S-703.14.2.1	7-33
Granular Materials for Subbases and Bases Mechanically Stabilized Courses	S-703.07.2 S-703.08	7-29 7-31
Stabilizer Aggregate Guide for Removal of False- work, Forms & Housing:	S-703.20.3	7-37
Bridges	S-804.03.15	8-78
Minor Structures	S-601.09.3	6-2
Liquidated Damages	S-108.07	1-73
Master Proportion Table for: Structural Concrete	S-804.02.10	8-56
Rates of Application of Seal Coats, Table 410-A	S-410	4-56, 4-57 & 4-58
Requirements for: Asphalt Cement (Petroleum), Table I	S-702.12	7-17
Table II	S-702.12	7-18
Bituminous Materials, Specifications for prime-Table III	S-702.12	7-19
Surface Tolerance for Layers of Asphalt Pavement	S-403.03.2	4-30
Working Temperatures for-Table IV	S-702.12	7-19
Tack Coat	S-407	4-41
Taxes	S-107.02	1-50
Temporary Structures, Definition of	S-101.02	1-12
Temporary Suspension of Work	S-108.04.3	1-70
Test Portion, Definition of	S-700.02	7-4
Test Result, Definition of	S-700.02	7-4
Test Value, Definition of	S-700.02	7-4
The Work, Definition of	S-101.02	1-12
Thinners for Paint	S-710.01.1	7-66
Timber and Lumber	S-718	7-130
Titles (or Headings), Definitions of	S-101.02	1-12

**Topic****Section or  
Subsection****Page**

## Tolerances:

Conformity	S-700.04	7-5
Topsoil	S-715.01	7-107
Topsoiling	S-211	2-31
Township, Definition of	S-101.02	1-12
Traffic Island Pavement	S-616	6-60
Traffic, Maintenance of	S-104.04	1-26
Detail Stripe	S-619.06	6-74
Traffic Markings, Painted	S-619	6-72
Traveled Way, Definition of	S-101.02	1-12
Treatment, Preservation Oils for Timber	S-718.04	7-132
Trench, Imperfect	S-603.10	6-15
Truck Mixers and Truck Agitators	S-804.03.6.1	8-68
Turn of the Nut Tightening	S-810.03.1.4	8-135

**INDEX****U**

Unacceptable and Un- authorized Work, Removal of	S-105.12	1-38
Unacceptable Materials	S-106.10	1-49
Unclassified Excavation	S-203.02.1	2-8
Underdrains	S-605	6-28
Use of Explosives	S-107.11	1-55
Utilities, Cooperation with	S-105.06	1-34
Utilities, Responsibility for	S-107.18	1-59

**INDEX****V**

Value Engineering Incentive	S-104.08	1-29
Volume Change, Definition Of	S-700.02	7-4

## W

<b>Topic</b>	<b>Section or Subsection</b>	<b>Page</b>
Warning Signs	S-107.10	1-53
	S-630	6-86
Water	S-714.01	7-87
Water-Cement Ratio, Definition of	S-700.02	7-4
Welders, Qualification for	S-810.03.5	8-139
Welding	S-812.02.3	8-156
Wire Rope or Wire Cable for Prestressed Concrete	S-711	7-78
Work:		
Acceptance of	S-105.16	1-40
Character of	S-104.02	1-25
Control of	S-105	1-31
Extra	S-109.04	1-81
Failure to Complete on Time	S-108.07	1-73
Inspection of	S-105.11	1-38
Order, Definition of	S-101.02	1-12
Removal of Unacceptable & Unauthorized	S-105.12	1-38
Scope of	S-104	1-25
Temporary Suspension of	S-108.04.3	1-70
The, Definition of	S-101.02	1-12
Working Day, Definition of	S-101.02	1-12
Working Drawings, Definitions of	S-101.02	1-13
Working Temperature for Bituminous Materials Table IV	S-702.12	7-19
Workmen, Character of	S-108.05	1-71









**STATE AID - 2004**